

AGS Wye Type Vic-Strainer®



SERIES W732

Series W732 AGS Vic-Strainer provides straight through flow for lower pressure drop. Installs with two Victaulic couplings. W732 Vic-Strainers range in size from 14 – 18"/350 – 450 mm. All sizes are rated to 300 psi/2065 kPa maximum working pressure.

Durable 304 stainless perforated metal basket, 0.156"/4 mm diameter holes for 14-18"/350-450 mm sizes.



For information on the Series 732 Wye Type Vic-Strainer in 2 – 12"/50 – 300 mm sizes, request publication 09.03.



WARNING

WARNING

- Always depressurize and drain piping systems before attempting to install, remove, or adjust any Victaulic piping products.

Failure to follow this instruction could result in serious personal injury, property damage, joint leakage, and/or joint failure.

WARNING

When grooving pipe for use with AGS products, Victaulic roll grooving tools must be equipped with AGS roll sets (RW for steel or RWX for stainless steel).

Victaulic AGS products **MUST NOT** be installed on pipe that is prepared with original-type grooving roll sets.

Failure to follow these instructions will cause grooves that are not within Victaulic AGS specifications, resulting in joint failure, serious personal injury, and property damage.

<p>JOB OWNER</p> <p>System No. _____</p> <p>Location _____</p>	<p>CONTRACTOR</p> <p>Submitted By _____</p> <p>Date _____</p>	<p>ENGINEER</p> <p>Spec Sect _____ Para _____</p> <p>Approved _____</p> <p>Date _____</p>
---	--	--

AGS Wye Type Vic-Strainer®

SERIES W732

**MATERIAL SPECIFICATIONS**

Body, Coupling, End Cap: Ductile iron conforming to ASTM A-395, grade 65-45-15, and ASTM A-536, grade 65-45-12.

Coating: Orange enamel.

Basket: Stainless Steel, Type 304, perforated metal.

- 14-18"/350-450mm: 0.156"/4 mm diameter perforations on 0.234"/6 mm centers, 40% open area.

Gasket Grade: (specify choice*)†

- **Grade "E" EPDM**

EPDM (Green color code). Temperature range –30°F to +230°F/–34°C to +110°C.

Recommended for cold and hot water service within the specified temperature range plus a variety of dilute acids, oil-free air and many chemical services. UL classified in accordance with ANSI/NSF 61 for cold +86°F/+30°C and hot +180°F/+82°C potable water service. NOT RECOMMENDED FOR PETROLEUM SERVICES.*

*Services listed are General Service Recommendations only. It should be noted that there are services for which these gaskets are not recommended. Reference should always be made to the latest Victaulic Gasket Selection Guide for specific gasket service recommendations and for a listing of services which are not recommended.

† Supplemental lubricant is recommended for services installed at or continuously operating below 0°F/–18°C.

Bolts/Nuts: Heat treated carbon steel zinc electroplated to ASTM B-633, track head conforming to physical properties of ASTM A-183 minimum tensile 110,000 psi/758340 kPa.

Couplings: Series W732 AGS Vic-Strainer is supplied with a Style W07 AGS Rigid coupling for cleaning access.

Blow Down Port: An NPT tap is provided in the cap for a discharge valve connection allowing solids to be "blown down" while the system is in service. Strainer supplied with cap plugged.

Other: Special requirements can often be met. Contact Victaulic with specific requirements for recommendations, availability and delivery.

AGS Wye Type Vic-Strainer®



SERIES W732



DIMENSIONS

Size		Max. Work Pressure psi kPa	Dimensions – Inches/mm											Approx. Wgt. Each	
Nominal Size Inches/ mm	Actual Outside Diameter Inches/ mm		End to End A	B	C	D	E	F	G	H	J	K "TAP"	L	M	Lbs. kg
14	14.00	300	34.00	25.93	8.07	25.27	29.13	18.15	20.59	2 NPT	7.09	¼"	3.35	7.87	425
350	355.60	2065	863.6	658.6	205	641.8	739.8	461	523.0		180	180	85	200.0	192.8
16	16.00	300	37.00	27.35	9.65	27.15	30.70	20.47	23.51	2 NPT	7.87	¼"	3.74	8.88	600
400	406.40	2065	939.8	694.8	245	689.5	779.8	520	597.2		200	200	95	225.5	272.2
18	18.00	300	40.51	30.27	10.24	29.94	33.61	23.39	25.53	2 NPT	7.87	¼"	3.74	9.88	800
450	457.20	2065	1028.9	768.9	260	760.5	853.8	594	648.5		200	200	95	251.0	362.9

#Working pressure is maximum and will be governed by couplings used for installation and related system components. Maximum differential pressure from inlet to outlet must not exceed 10 psi/69 kPa.

*Dimensions will vary depending upon coupling orientation.

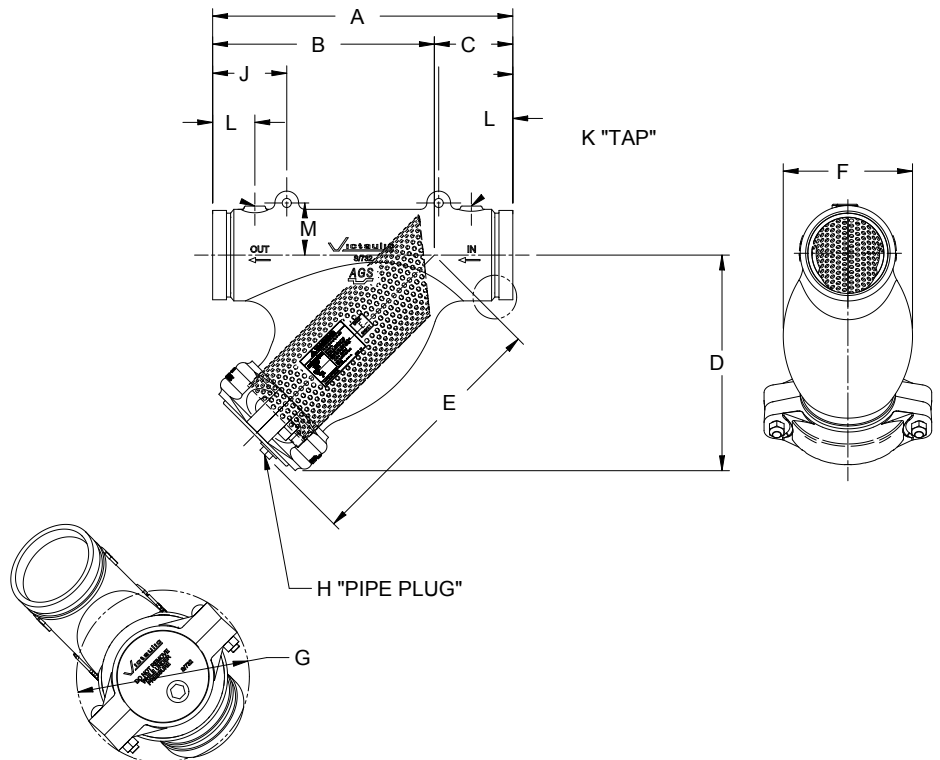

AGS Wye Type Vic-Strainer®



SERIES W732



PERFORMANCE

The chart below expresses the flow of water at 65°F/18°C.

FLOW CHARACTERISTICS

Flow characteristics are based on standard, clean baskets. Flow may vary from these figures.

Flow Data

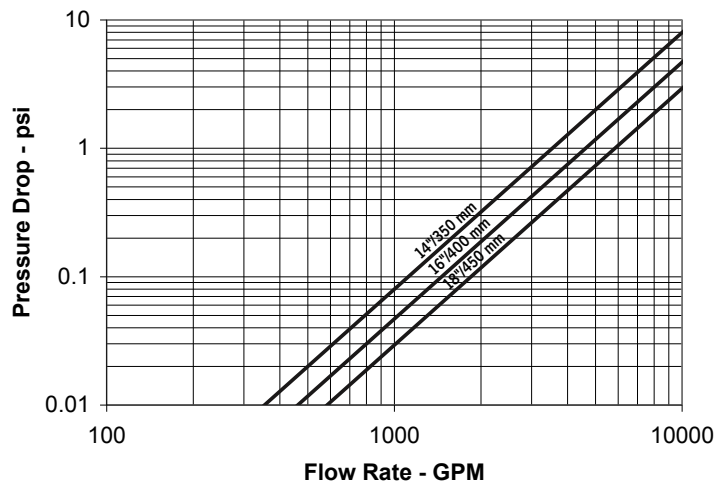

Flow Data

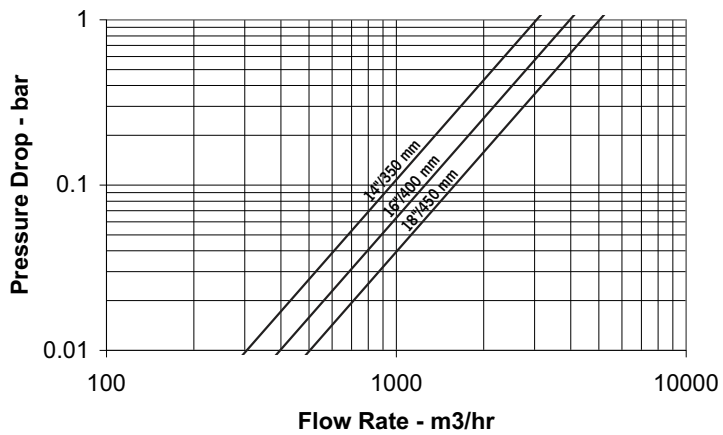

AGS Wye Type Vic-Strainer®



SERIES W732



FLOW RATE

C_v and K_v values for flow of water at +60°F/+16°C are shown in tables below.

Formulas for C_v and K_v values:

$$\Delta P = \frac{Q^2}{C_v^2}$$

$$Q = C_v \times \sqrt{\Delta P}$$

Where:

Q = Flow (GPM)

ΔP = Pressure Drop (psi)

C_v = Flow Coefficient

$$\Delta P = \frac{Q^2}{K_v^2}$$

$$Q = K_v \times \sqrt{\Delta P}$$

Where:

Q = Flow (m³/h)

ΔP = Pressure Drop (bar)

K_v = Flow Coefficient

Size		C_v / K_v
Nominal Size Inches/mm	Actual Outside Diameter Inches/mm	Full Open
14 350	14.00 355.60	3534 3014
16 400	16.00 406.40	4616 3937
18 450	18.00 457.20	5842 4983

MINIMUM CLEARANCE REQUIREMENTS FOR REMOVAL OF SUCTION DIFFUSER BASKETS

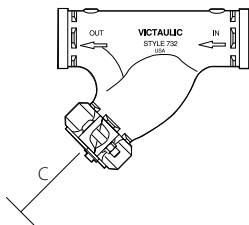

Pipe Size		"C" Strainer Basket Minimum Clearance inches/mm
Nominal Diameter inches/mm	Actual Outside Diameter inches/mm	Series W732
14 350	14.000 355.6	30.00 762
16 400	16.000 406.4	32.00 813
18 450	18.000 457.0	35.00 889

AGS Wye Type Vic-Strainer[®]



SERIES W732



AGS Wye Type Vic-Strainer®

SERIES W732



AGS Wye Type Vic-Strainer®

SERIES W732

AGS™**WARRANTY**

Refer to the Warranty section of the current Price List or contact Victaulic for details.

NOTE

This product shall be manufactured by Victaulic or to Victaulic specifications. All products to be installed in accordance with current Victaulic installation/assembly instructions. Victaulic reserves the right to change product specifications, designs and standard equipment without notice and without incurring obligations.



WCAS-7D6NLH