

Flexible High Pressure Coupling for Applied Vic-Ring Systems

STYLE 277

The patented Style 277 coupling is comprised of two housings and is designed to provide a strong connection for large diameter piping systems with working pressures up to 650 psi/4500 kPa. The unique wedge-shaped groove profile required for this coupling helps align the coupling in the groove, resulting in easier initial assembly alignment. The Style 277 coupling is assembled on the Vic-Ring to complete the joint. This flexible coupling has deflection capabilities that can assist with routing pipe over uneven surfaces.

The Style 277 coupling may be installed on lined or un-lined pipe.

A Style 207 rigid high pressure coupling is also available. Request publication 16.09 for details.



Patented

MATERIAL SPECIFICATIONS

Housings:

- Material:
Ductile Iron conforming to ASTM A536 Grade 65-45-12
- Finish:
Orange enamel

Gaskets (specify choice when ordering):

- **Grade "L" Silicone**
Temperature range -30°F to +350°F/-34° C to +177°C. Recommended for dry heat, air without hydrocarbons to +350°F/+177°C and certain chemical services.
NOTE: Other compounds are available. Contact Victaulic for details.
- **Grade "E" EPDM**
EPDM (Green color code) Temperature range -30°F to +230°F(-34°C to + 110°C). Recommended for cold and hot water service within the specified temperature range plus a variety of dilute acids, oil-free air and many chemical services. UL Classified in accordance with ANSI/NSF 61 for cold +86°F(+30°C) and hot +182°F(+82° C) potable water service.
NOT RECOMMENDED FOR PETROLEUM SERVICES.

Bolts/Nuts/Washers: Four sets per coupling

- Material:
Bolts: Heat-treated, plated carbon steel, trackhead, meeting the physical and chemical requirements of ASTM A-449, and physical requirements of ASTM A-183
Nuts: Plated carbon steel, heavy hex, conforming to ASTM A-563
Washers: Plated carbon steel, flat SAE high strength, conforming to ASTM F- 436
- Bolt Torque:
See torque values table on page 3.

Vic-Rings: Victaulic Type 'B' Vic-Rings

- Material:
Carbon Steel to ASTM A 105
- Other materials can be supplied, contact Victaulic for details.

JOB/OWNER

System No. _____
Location _____

CONTRACTOR

Submitted By _____
Date _____

ENGINEER

Spec Sect _____ Para _____
Approved _____
Date _____

Flexible High Pressure Coupling for Applied Vic-Ring Systems

STYLE 277

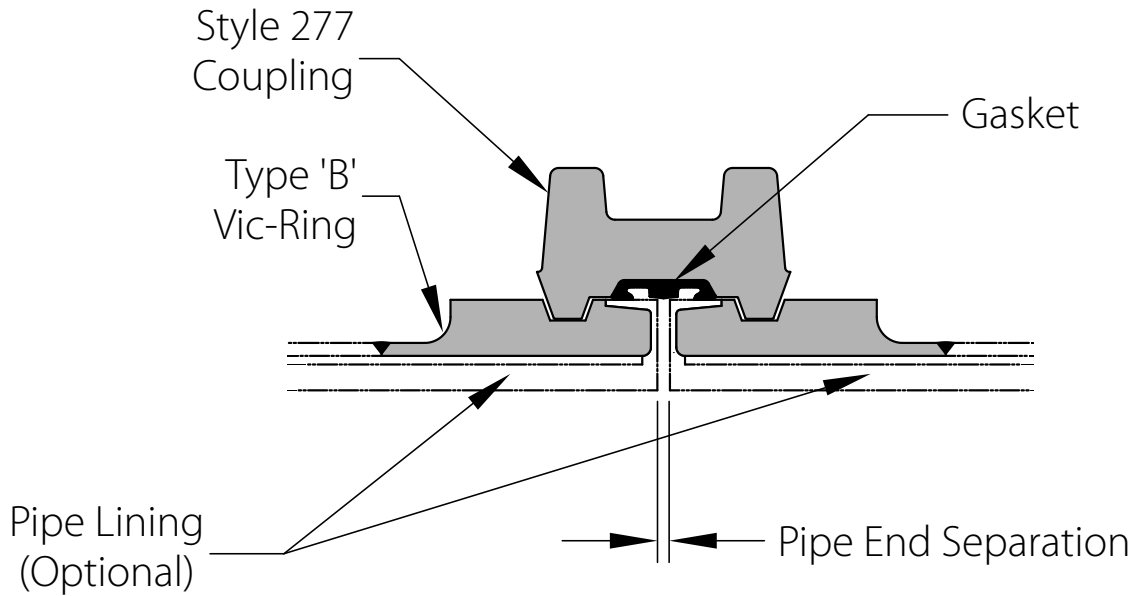

Install couplings in accordance with Victaulic's published installation instructions for large diameter couplings provided with each shipment.

Flexible High Pressure Coupling for Applied Vic-Ring Systems

STYLE 277

DIMENSIONS

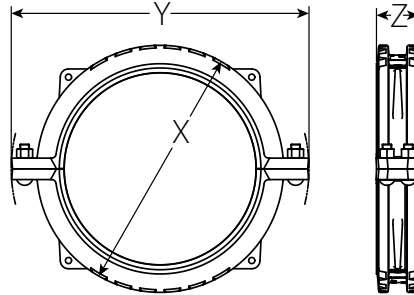

Size	Dimensions – Inches/millimeters			Bolt/Nut/Washer	Weight Ea.
In. / mm	X	Y	Z	No. -Size	Lbs. / Kg
26 650	36.32 923	44.39 1128	6.93 176	4 - 1½ x 7	610.0 276.7
28 700	38.32 973	46.38 1178	6.93 176	4 - 1½ x 7	640.0 290.3
30 750	40.32 1024	48.63 1235	6.93 176	4 - 1½ x 7	690.0 313.0
32 800	42.62 1083	50.12 1273	7.30 185	4 - 1½ x 7	790.0 358.3
36 900	47.12 1197	56.23 1428	7.30 185	4 - 1¾ x 8	940.0 426.4

TORQUE REQUIREMENTS

Size	Actual Outside Dia.	Recommended Torque
Nominal In. / mm	(Vic-Ring OD)	ft./lbs. N-m
26 & 28 650 & 700	28.50 & 30.50 725 & 775	750 1000
30 & 32 750 & 800	32.50 & 34.50 825 & 875	850 1150
36 900	38.50 975	900 1225

Flexible High Pressure Coupling for Applied Vic-Ring Systems

STYLE 277

JOINT PERFORMANCE DATA

Pipe Size In. / mm	Vic-Ring Dia. In. / mm	Pipe Wall Thickness*	Max Working Pressure PSI / kPa	Allowable Pipe End Sep. In. / mm	Deflection from CL		Max End Load lbs / N
					Per Cplg. Degree	Pipe In. / Ft. - mm/m	
26 650	28.50 724	0.375 9.5	650 4500	0 - 0.25 0 - 6.4	0.50	0.11 9	414660 1844500
28 700	30.50 775	0.375 9.5	650 4500	0 - 0.25 0 - 6.4	0.47	0.10 8	474900 2112460
30 750	32.50 825	0.375 9.5	650 4500	0 - 0.25 0 - 6.4	0.44	0.09 8	539225 2398600
32 800	34.50 876	0.375 9.5	650 4500	0 - 0.25 0 - 6.4	0.42	0.09 7	607640 2702920
36 900	38.50 978	0.375 9.5	650 4500	0 - 0.25 0 - 6.4	0.37	0.08 7	756700 3365970

* For performance on heavier wall pipe contact Victaulic for details.

Important:

The joint performance data which is published in this document only applies to genuine Vic-Ring™ adapters designed and supplied by the Victaulic Company. The Victaulic Company cannot warrant the performance of joints using adapter rings supplied by others.

INSTALLATION

Reference should always be made to the Installation Instructions for the product you are installing. Instructions are included with each shipment for complete installation and assembly data, and are available in PDF format on our website at www.victaulic.com.

WARRANTY

Refer to the Warranty section of the current Price List or contact Victaulic for details.

NOTE

This product shall be manufactured by Victaulic or to Victaulic specifications. All products to be installed in accordance with current Victaulic installation/assembly instructions. Victaulic reserves the right to change product specifications, designs and standard equipment without notice and without incurring obligations.

For complete contact information, visit www.victaulic.com

16.08 5401 REV B UPDATED 07/2009

VICTAULIC IS A REGISTERED TRADEMARK OF VICTAULIC COMPANY. © 2009 VICTAULIC COMPANY. ALL RIGHTS RESERVED.

16.08

