

245 and 246 Redi-Clamp

Product Specifications

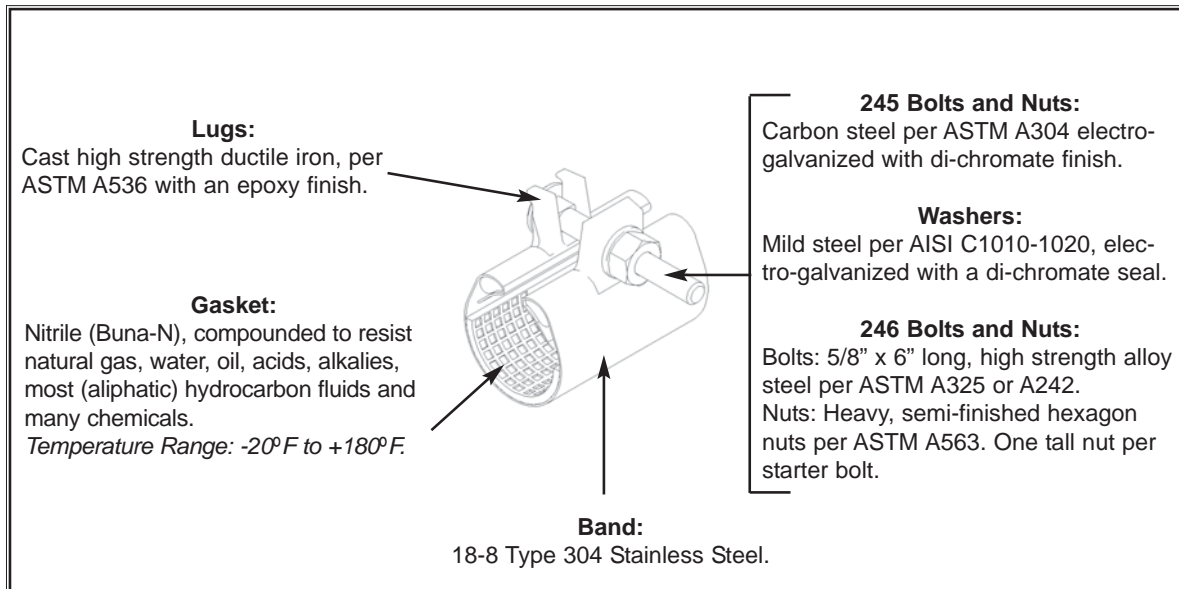

Features:

- Drop in bolts to ease installation.
- Available in 1/8" or 1/4" thick gasket material.
- Available in smooth or gridded gasket material.
- Standard widths or 3", 6", 9" and 12" in the 245.
- Lugs have an epoxy coating for great corrosion resistance.
- 18-8 Type 304 Stainless Steel band for corrosion resistance.
- Standard widths of 5" and 10" in the 246. Other widths available.
- Built to a specific pipe O.D. and available in IPS and copper tube sizes.
- Economical means of repairing pin hole leaks, punctures and splits in pipe.
- Always available with lug-to-lug gasket in the 1/2" to 2" O.D.'s and available as an option in the 2 1/2" and larger O.D.'s.

Clamp Number	Size	Working Pressure*
245	1/2"-12" Nominal	Up to 250 PSI
246	10" and larger Nominal	Up to 250 PSI

*The allowable working pressure of a pipe repair clamp decreases as pipe diameter increases (regardless of manufacturer). For a particular installation, the allowable working pressure will be determined by the size of pipe, type of pipe, type of clamp, type and extent of damage, service conditions, environmental conditions, and installation workmanship.

Product Specifications

SPECIFICATION:

The 245 Redi-clamp shall have an 18-8 type 304 stainless steel band. The band shall be a minimum of 3" in width.

The lugs shall be made of high strength ductile iron per ASTM A536 and have an epoxy coating. The 245 lugs shall be attached to the band by wrapping the end of the band around the lug base. The 246 lugs shall be attached to the band by hemming the band and sliding it into the lug slot.

The slot shall be cast into the lug base. The 246 lug shall have a friction fit with the band, preventing it from sliding off yet allowing for easy removal and reattachment in case of installing the clamp in restricted spaces.

The gasket shall be Nitrile (Buna N) specially compounded to resist water, oil, acids, alkalies, natural gas, most (aliphatic) hydrocarbon fluids, and many other chemicals. The temperature range shall be -20°F thru +180°F.

The gasket shall have a gridded pattern (or smooth) and be 1/8" (or 1/4") thick. The nuts and bolts shall be carbon steel per ASTM A304 and electro-galvanized with a di-chromate finish. The washers shall be mild steel per AISI C1010-1020 and electro-galvanized with a di-chromate seal.

OPTIONAL - Stainless steel type 304 bolts, nuts and washers. The nuts shall be fluoropolymer coated to prevent galling.

The clamp shall be a Smith-Blair, Inc., 245, 246 Redi-Clamp or approved equal.

Approved By
Name:
Title:
Date:

THESE PRODUCT SPECIFICATIONS WERE CORRECT AT TIME OF PUBLICATION.

MATERIAL SPECIFICATIONS ARE SUBJECT TO CHANGE WITHOUT NOTICE.

SEE CATALOG BROCHURE CC-200 FOR MORE DETAILS. VISIT SMITH-BLAIR'S WEBSITE AT WWW.SMITH-BLAIR.COM TO DOWNLOAD THE MOST CURRENT INFORMATION.



Ph: 870-773-5127 • Fax: 870-773-5212 • www.smith-blair.com
Toll-Free Numbers: Ph: 800-643-9705 • Fax: 800-648-6792
30 Globe Ave, Texarkana, AR 71854 • PO Box 5337, Texarkana, TX 75505