

Full Circle Repair Clamps

229

Product Specifications

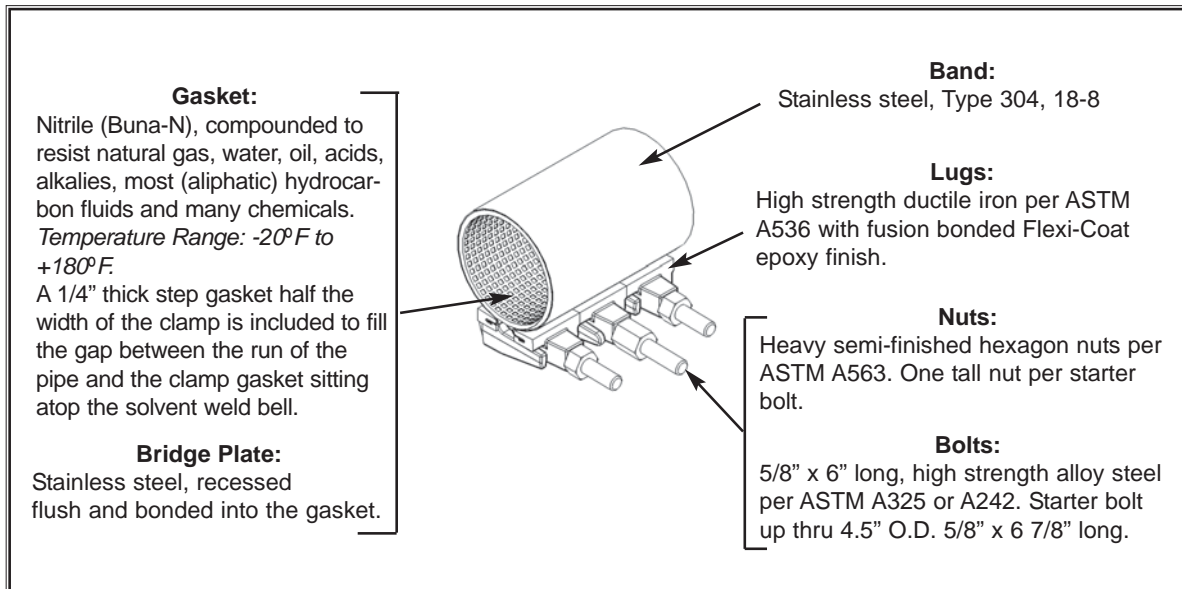

Features:

- Pressure rated 229 - up to 150 PSI.
- Removable lugs to allow installation in tight spaces.
- 18-8 Type 304 Stainless Steel band for corrosion resistance.
- A 360° Gasket seal provides maximum support and reinforcement.
- Stop gasket seals against the face of solvent weld bell to stop the leak.
- Use on leaking solvent weld PVC joints and most threaded steel couplings.
- Lugs have a fusion bonded Flexi-Coat epoxy coating for corrosion resistance.
- One starter (longer) bolt minimum per clam thru 4.5" O.D. size to help with installation.

Clamp Number	Size	Working Pressure*
229	2"-12" Nominal	150 PSI

*The allowable working pressure of a pipe repair clamp decreases as pipe diameter increases (regardless of manufacturer). For a particular installation, the allowable working pressure will be determined by the size of pipe, type of pipe, type of clamp, type and extent of damage, service conditions, environmental conditions, and installation workmanship.

Product Specifications

SPECIFICATION:

The full circle repair clamp shall have an 18-8 Type 304 stainless steel band. It shall be a minimum of 7.5" in width (5" minimum width for the 221). The lugs shall be made of high strength ductile iron per ASTM A536 and have a fusion bonded Flexi Coat epoxy coating.

The lugs shall be attached to the band by hemming the band and sliding it into the lug slot. The slot shall be cast into the lug base. The lug shall have a friction fit with the band, preventing it from sliding off yet allowing for easy removal and reattachment in case of installing the clamp in restricted spaces.

The gasket shall be made of Nitrile (Buna N) specially compounded to resist water, oil, acids, alkalies, natural gas, most (aliphatic) hydrocarbon fluids, and many other chemicals. The temperature range of the gasket shall be -20°F thru +180°F. The

gasket must have a bridge plate that helps the end of the clamp band to seal across the gap. The bridge plate shall be made of quarter-hard 304 stainless steel. It shall be recessed and bonded into the gasket. The gasket shall have a gridded pattern. The gasket shall be tapered on the ends and overlap for range capability.

The bolts shall be 5/8" x 6" high strength low alloy per ANSI A21.11. At least one 5/8" x 6 7/8" bolt with a taller nut shall be furnished to help facilitate installation of clamps up thru 4.50" O.D. Heavy semi-finished nuts meeting ASTM A563 shall be provided with the bolts. Multi-band clamps shall have all closed lugs except for one set of open and closed lugs to allow for easy opening and installation of the clamp.

OPTIONAL - Stainless steel type 304 bolts and nuts. The nuts shall be fluoropolymer coated to prevent galling.

The clamp shall be a Smith-Blair, Inc., 229 full circle clamp or approved equal.

Approved By
Name:
Title:
Date:

*THESE PRODUCT SPECIFICATIONS WERE CORRECT AT TIME OF PUBLICATION.
MATERIAL SPECIFICATIONS ARE SUBJECT TO CHANGE WITHOUT NOTICE.
SEE CATALOG BROCHURE CC-200 FOR MORE DETAILS. VISIT SMITH-BLAIR'S
WEBSITE AT WWW.SMITH-BLAIR.COM TO DOWNLOAD THE MOST CURRENT INFORMATION.*



**Ph: 870-773-5127 • Fax: 870-773-5212 • www.smith-blair.com
Toll-Free Numbers: Ph: 800-643-9705 • Fax: 800-648-6792
30 Globe Ave, Texarkana, AR 71854 • PO Box 5337, Texarkana, TX 75505**