



TBB Series Industrial True Union Ball Valves

1/2" to 4" - PVC, Corzan® CPVC, PPL, and PVDF



Features

- Full Port Design
- Easy Maintenance
- FPM or EPDM Seals
- Easily Automated
- Double O-Ring Stem Seals
- Adjustable Seat Retainer

Options

- Stem Extensions
- Lockouts
- 2" Square Operating Nuts
- Drilled Balls for Sodium Hypochlorite Service

Rugged Construction

Hayward's TBB Series Industrial True Union Ball Valves are cost effective, yet rugged enough to stand up to demanding industrial and commercial applications.

True Union Design

This makes these valves very easy to maintain by allowing for easy removal from a piping system without breaking down piping connections. Just unscrew the two assembly nuts and lift the valve body out of the line.

Advanced Design Features

TBB Series True Union Ball Valves are superior performers. They have a threaded seal carrier that allows the seat to be adjusted while maintaining downstream pressure. These valves feature a dovetail ball and stem, and a thick double o-ring stem seal for twice the leakage protection of valves with only a single stem seal.

Actuator Mounting Design

For actuator mounting, the valve incorporates a unique design of two holes in the stem body that allows the actuator mounting bracket to mount directly to the valve without the need for glued or clamped-on mounting pads. This assures proper alignment of the actuator to the valve without creating any damaging side loads to cause premature stem seal failure. With this design, the valve can easily be adapted to manual operation – should the need ever arise.

Never a Problem with Corrosion

Because of the valves' all plastic construction, they will never rust or corrode – and they can survive corrosive environments without the need for painting or expensive epoxy coating.



Technical Information

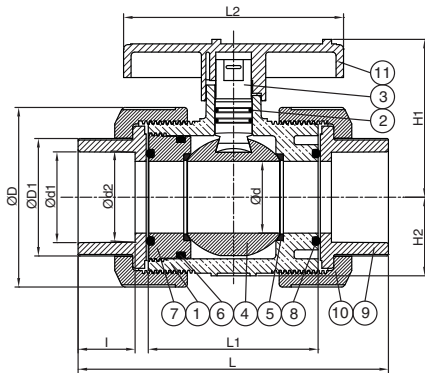

Parts List True Union Valve

1. Body
2. Stem O-Ring
3. Stem
4. Ball
5. Seat Seal
6. Carrier O-Ring
7. Seal Carrier
8. Union O-Ring
9. End Connector
10. Union Nut
11. Handle
12. Inserted Nut

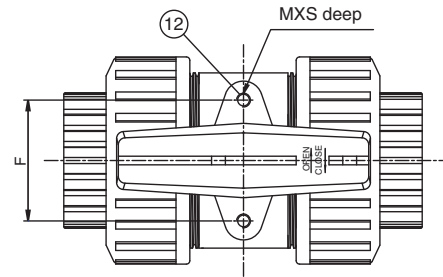

Dimensions - Inches / Millimeters

Size	d1	d2	l	D	D1	d
1/2 / 15	.85 / 21.54	.84 / 21.23	.87 / 22.22	1.83 / 46.5	1.23 / 31.3	.51 / 13
3/4 / 20	1.06 / 26.87	1.05 / 26.57	1.00 / 25.4	2.17 / 55	1.46 / 37	.71 / 18
1 / 25	1.32 / 33.65	1.31 / 33.27	1.13 / 28.58	2.60 / 66	1.75 / 44.5	.91 / 23
1-1/4 / 32	1.67 / 42.42	1.66 / 42.04	1.25 / 31.75	3.23 / 82	2.13 / 54	1.18 / 30
1-1/2 / 40	1.91 / 48.56	1.89 / 48.11	1.38 / 34.93	3.86 / 98	2.54 / 64.5	1.50 / 38
2 / 50	2.39 / 60.63	2.37 / 60.17	1.50 / 38.1	4.72 / 120	3.09 / 78.5	1.89 / 48
2-1/2 / 65	2.89 / 73.38	2.87 / 72.85	1.75 / 44.45	5.51 / 140	3.60 / 91.5	2.40 / 61
3 / 80	3.52 / 89.31	3.49 / 88.7	1.88 / 47.63	6.42 / 163	4.23 / 107.5	2.70 / 68.5
4 / 100	4.52 / 114.76	4.49 / 114.07	2.25 / 57.15	8.86 / 225	5.73 / 145.5	3.90 / 99

Size	L	L1	L2	H1	H2	F
1/2 / 15	4.49 / 114	2.36 / 60	3.07 / 78	1.85 / 47	.81 / 20.5	1.2 / 30
3/4 / 20	5.31 / 135	2.87 / 73	3.62 / 92	2.24 / 57	1.02 / 26	1.3 / 33
1 / 25	5.87 / 149	3.11 / 79	3.94 / 100	2.60 / 66	1.30 / 33	1.6 / 40
1-1/4 / 32	6.61 / 168	3.46 / 88	4.33 / 110	2.91 / 74	1.50 / 38	1.9 / 47
1-1/2 / 40	6.89 / 175	3.72 / 94.5	4.76 / 121	3.43 / 87	1.57 / 40	2.0 / 52
2 / 50	8.15 / 207	4.47 / 113.5	5.79 / 147	4.17 / 106	2.09 / 53	2.8 / 70
2-1/2 / 65	10.83 / 275	5.43 / 138	7.09 / 180	4.57 / 116	-	-
3 / 80	11.97 / 304	6.22 / 158	8.82 / 224	5.12 / 130	-	-
4 / 100	13.03 / 331	6.93 / 176	10.94 / 278	7.01 / 178	-	-

Selection Chart

Size	Material	End. Conn	Seals	Pressure Rating
1/2" - 4"	PVC, CPVC	Socket, Threaded or Flanged	FPM or EPDM	225 PSI @70°F Non-Shock
1/2" - 4"	PPL*	Threaded or Flanged		
1/2" - 4"	PVDF	Socket, Threaded or Flanged	FPM	

* PPL rated at 150 PSI

Operating Temperature/Pressure

