



DAB Series Industrial Diaphragm Valves

1/2" to 6" PVC

1/2" to 4" CPVC

1/2" to 10" PPL

1/2" to 8" PVDF



Features

- Position Indicator
- Sure-Grip Handwheel
- Choice of EPDM, FPM, PTFE Diaphragms
- Rated to 150 PSI

Options

- Electric, Pneumatic Actuation to 4"
- Over 4" Actuation, Consult Factory
- True Union End Connections
- PVDF Vapor Barrier

Overview

Hayward all-plastic diaphragm valves are engineered to provide superior handling of difficult media such as corrosive fluids, abrasives and slurries. They can also be used for high purity and sanitary applications.

Manual or Automated

Available in manual or actuated (pneumatic or electric) models, the valves can be used for on/off and throttling service, feature a multi-turn design for precise control, and are self-draining on one side so that little to no dead volume remains in the valve. Standard material choices for the valve's body include PVC, CPVC, PVDF and PPL. Each are available with EPDM, FPM or PTFE diaphragms, allowing service in a wide range of applications.

Superior Design, Superior Performance

The valve controls flow by varying the space between a stationary weir and a moveable flexible diaphragm. By compressing the diaphragm against the weir, all flow is shut off. The only wetted components are the lower half of the valve body and the diaphragm. The diaphragm's stroke adjustment feature allows precise "tweaking" of diaphragm movement for very precise flow control. A large, sure-grip handwheel makes it easy to open or close the valve, and a beacon-type indicator provides highly visible position indication at the top of the valve's rising stem.

Connection Options

Connection options include molded-in ANSI flanges and ASTM True Union socket end connectors.



Technical Information – PVC/CPVC Flanged

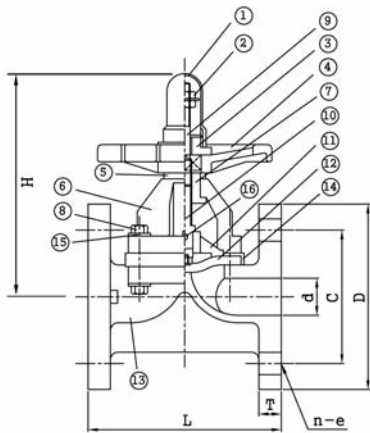

1/2" - 1-1/4" Parts List & Dimensions

- | | | |
|------------------|----------------|---------------------------|
| 1. Gauge Cap | 7. Sleeve | 13. Body |
| 2. Stopper Nut | 8. Bolt & Nut | 14. Diaphragm Cover Plate |
| 3. Lock Nut | 9. Stem | 15. Washer |
| 4. Hand Wheel | 10. Spindle | 16. Pin |
| 5. Thrust Washer | 11. Compressor | |
| 6. Bonnet | 12. Diaphragm | |

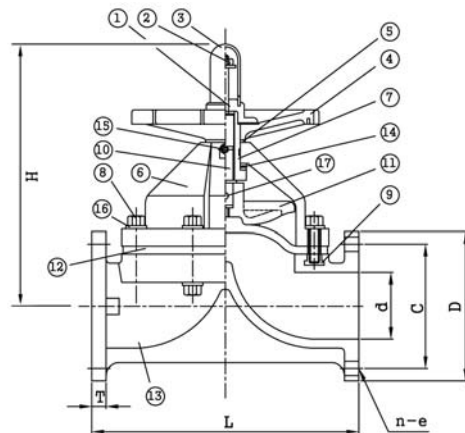

1-1/2" - 6" Parts List & Dimensions

- | | | |
|------------------|-----------------|-------------------------|
| 1. Lock Nut | 7. Sleeve | 13. Body |
| 2. Stopper Nut | 8. Bolt | 14. Thrust Ball Bearing |
| 3. Gauge Cap | 9. Inserted Nut | 15. Grease Nipple |
| 4. Hand Wheel | 10. Stem | 16. Washer |
| 5. Thrust Washer | 11. Compressor | 17. Pin |
| 6. Bonnet | 12. Diaphragm | |

Dimensions - Inches / Millimeters

Size	D	C	L	H	d	T	n-e
1/2/15	3.50/90	2.38/60	4.33/113	3.78/95	0.63/16	0.47/12	4-15.7
3/4/20	3.86/98	2.76/70	4.72/123	3.94/100	0.79/20	0.51/14	4-15.7
1/25	4.25/108	3.13/79	5.12/135	4.25/110	0.98/25	0.51/15	4-15.7
1-1/4/30	4.60/117	3.50/89	5.30/135	5.75/146	1.20/30	0.60/15	4-15.7
1-1/2/40	5.00/127	3.88/98	7.09/185	7.76/195	1.61/40	0.63/16	4-15.7
2/50	6.00/152	4.75/121	8.27/215	8.58/220	2.05/52	0.79/18	4-19
2-1/2/65	7.00/178*	5.50/140	9.84/255	10.24/260	2.64/65	0.91/20	4-19
3/80	7.50/190	6.00/152	11.02/285	10.63/270	3.07/79	0.91/21	4-19
4/100	9.00/229	7.50/191	13.39/346	11.81/300	3.94/102	0.94/21	8-19
6/150**	11.00/279	9.59/241	18.90/485	18.74/475	5.83/145	1.06/28	8-22

*CPVC – "D" dimension - 6.90/175

**6" available in PVC only.

Selection Chart

Size	Material	End Conn.	Diaphragm	Rating
1/2" - 6"	PVC	Flanged	EPDM, FPM, PTFE	1/2"-4" 150 PSI @ 70°F Non-shock 6" 75 PSI @ 70°F Non-shock
1/2" - 4"	CPVC	Flanged	EPDM, FPM, PTFE	1/2"-4" 150 PSI @ 70°F Non-shock



Technical Information – PPL/PVDF Flanged

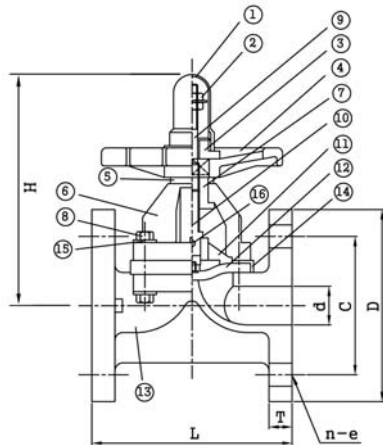

1/2" - 1-1/4" Parts List & Dimensions

- | | | |
|------------------|----------------|-------------------------|
| 1. Lock Nut | 7. Sleeve | 13. Body |
| 2. Stopper Nut | 8. Bolt | 14. Thrust Ball Bearing |
| 3. Gauge Cap | 9. Insert Nut | 15. Grease Nipple |
| 4. Hand Wheel | 10. Stem | 16. Washer |
| 5. Thrust Washer | 11. Compressor | 17. Pin |
| 6. Bonnet | 12. Diaphragm | |

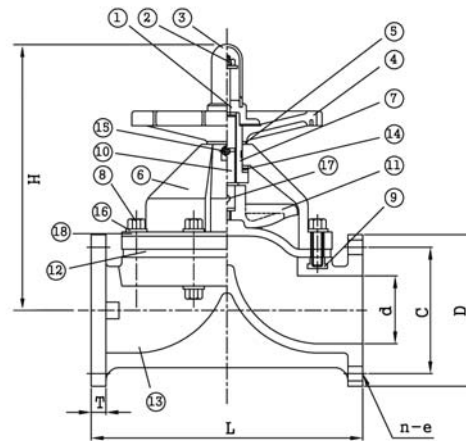

1-1/2" - 10" Parts List & Dimensions

- | | | |
|------------------|-----------------|-------------------------|
| 1. Lock Nut | 7. Sleeve | 13. Body |
| 2. Stopper Nut | 8. Bolt | 14. Thrust Ball Bearing |
| 3. Gauge Cap | 9. Inserted Nut | 15. Grease Nipple |
| 4. Hand Wheel | 10. Stem | 16. Washer |
| 5. Thrust Washer | 11. Compressor | 17. Pin |
| 6. Bonnet | 12. Diaphragm | 18. Plate |

Dimensions - Inches / Millimeters

Size	D	C	L	H	d	T	n-e
1/2/15	3.50/90	2.38/60	4.33/110	3.78/95	0.63/16	0.47/12	4-15.7
3/4/20	3.86/98	2.76/70	4.72/120	3.94/100	0.79/20	0.51/13	4-15.7
1/25	4.25/108	3.13/80	5.20/132	4.25/110	0.98/25	0.55/14	4-15.7
1-1/4/30	4.65/118	3.50/89	5.20/132	5.75/146	1.20/30	0.55/14	4-15.7
1-1/2/40	5.00/127	3.85/98	7.09/180	7.76/195	1.60/40	0.63/16	4-15.7
2/50	6.00/152	4.75/121	8.27/210	8.58/220	2.00/51	0.70/18	4-19
2-1/2/65	6.90/174	5.50/140	9.88/251	10.24/260	2.55/65	0.79/20	4-19
3/80	7.50/190	6.00/152	11.02/280	10.63/270	3.03/77	0.83/21	4-19
4/100	9.00/229	7.50/191	13.50/343	11.81/300	3.94/100	0.83/21	8-19
6/150	11.00/279	9.50/241	18.80/478	18.74/475	5.70/145	1.06/27	8-22
8/200	13.50/343	11.70/298	22.44/570	24.69/630	7.64/194	1.24/35	8-22
10/250*	16.00/406	14.25/362	26.70/680	27.55/700	9.72/247	1.46/35	12-25

*10" available in PPL only.

Selection Chart

Size	Material	End Conn.	Diaphragm	Rating
1/2" - 10"	PPL	Flanged	EPDM, FPM, PTFE	1/2"-4" 150 PSI @ 70°F Non-shock 6"-10" 75 PSI @ 70°F Non-shock
1/2" - 8"	PVDF	Flanged	PTFE	1/2"-4" 150 PSI @ 70°F Non-shock 6"-10" 75 PSI @ 70°F Non-shock



Technical Information – PVC/CPVC/PPL/PVDF True Union

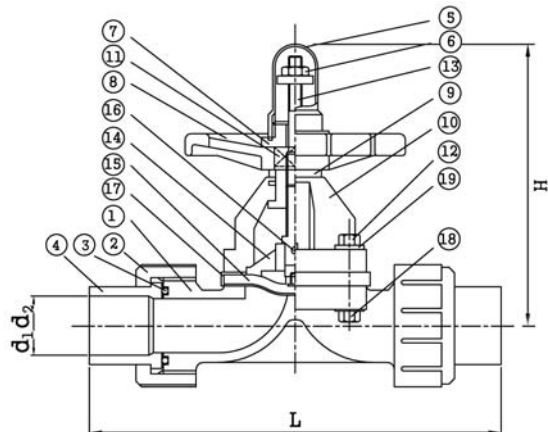

1/2" - 1" Parts List & Dimensions

- | | | |
|--------------------|------------------|---------------|
| 1. Union Body | 8. Hand Wheel | 15. Diaphragm |
| 2. Union Gland Cap | 9. Thrust Washer | 16. Pin |
| 3. Union O-Ring | 10. Bonnet | 17. Diaphragm |
| 4. Union Body Cap | 11. Sleeve | 18. Bolt |
| 5. Gauge Cap | 12. Nut | 19. Washer |
| 6. Stopper Nut | 13. Stem | |
| 7. Lock Nut | 14. Compressor | |

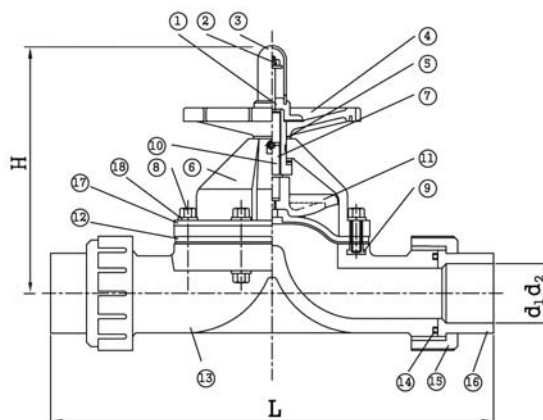

1-1/4" - 2" Parts List & Dimensions

- | | | |
|------------------|------------------|------------|
| 1. Lock Nut | 8. Bolt | 15. Union |
| 2. Stopper Nut | 9. Inserted Nut | Gland Cap |
| 3. Gauge Cap | 10. Sleeve | 16. Union |
| 4. Hand Wheel | 11. Compressor | Body Cap |
| 5. Thrust Washer | 12. Diaphragm | 17. Plate |
| 6. Bonnet | 13. Unionbody | 18. Washer |
| 7. Stem | 14. Union O-Ring | |

Dimensions - Inches / Millimeters

Socket (PVC/CPVC/PPL)

Size	L	d ₁	H
1/2/15	5.90/150	0.85/21.5	3.74/95
3/4/20	6.69/170	1.06/26.9	3.94/100
1/25	7.95/202	1.32/33.6	4.33/110
1-1/4/30	11.22/285	1.91/48.6	7.67/195
1-1/2/40	11.22/285	1.91/48.6	7.67/195
2/50	12.79/325	2.39/60.6	8.27/210

Threaded (PVC/CPVC/PPL/PVDF)

Size	L	d ₂	H
1/2/15	5.55/141	1/2-14 NPT	3.74/95
3/4/20	6.22/159	3/4-14 NPT	3.94/100
1/25	7.17/182	1-11.5 NPT	4.33/110
1-1/4/30	10.63/270	1-1/4-11.5 NPT	7.67/195
1-1/2/40	10.63/270	1-1/2-11.5 NPT	7.67/195
2/50	12.13/308	2-11.5 NPT	8.27/210

Socket (PVDF)

Size	L	d ₁	H
1/2/15	5/90/150	0.88/22.4	3.74/95
3/4/20	6.69/170	1.04/26.4	3.94/100
1/25	7.95/202	1.28/32.5	4.33/110
1-1/4/30	11.22/285	1.91/48.6	7.67/195
1-1/2/40	11.22/285	1.91/48.6	7.67/195
2/50	12.79/325	2.39/60.6	8.27/210

Selection Chart

Size	Material	End Conn.	Diaphragm	O-Rings	Rating
1/2", 3/4", 1", 1-1/4", 1-1/2", 2"	PVC/CPVC/PPL/PVDF	Socket or Threaded	EPDM, FPM, OR PTFE	FPM, EPDM	150 PSI @ 70°F Non-shock



Technical Information - PVC/CPVC/PPL Threaded Body

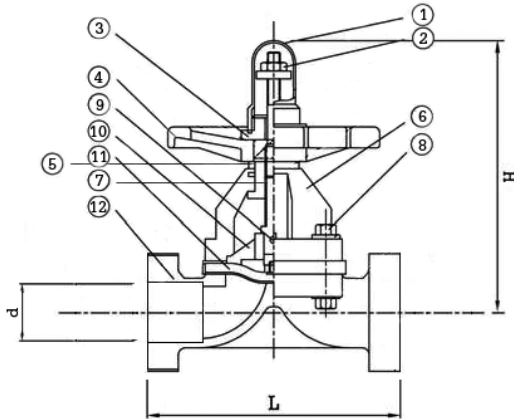

Parts List Diaphragm Valves (Threaded)

1. Gauge Cap
2. Stopper Nut
3. Lock Nut
4. Hand Wheel
5. Thrust Washer
6. Bonnet
7. Sleeve
8. Bolt
9. Stem
10. Compressor
11. Diaphragm
12. Body

Dimensions - Inches / Millimeters

Size	H	d	L
1/2/15	4.9/125	1/2-14 NPT	3.2/80
3/4/20	5.1/130	3/4-14 NPT	3.7/95
1/25	5.5/140	1-11.5 NPT	4.2/106

Selection Chart

Size	Material	End Conn.	Diaphragm	Rating
1/2"-1"	PVC/CPVC/PPL	Threaded	EPDM, FPM, OR PTFE	100 PSI @ 70°F Non-shock
1/2"-1"	PVDF	Threaded	PTFE	100 PSI @ 70°F Non-shock