



ProFile2™ Proportional Control All-Plastic Ball Valves

1" to 6" - PVC, Corzan® CPVC



CONTROL VALVES

Two Proportional Flow Control Rates with One Valve

Hayward ProFile2 corrosion resistant, proportional control ball valves provide two linear flow curves – one for fast opening, one for slow opening. The percentage of flow through the valves with either flow curve is equal to the degree of opening. As the valves are opened or closed, the flow varies in direct proportion to the valve opening. This permits predictable, accurate control of the downstream flow rate with a 1/4-turn valve.

Unique-Design “Characterized” Ball

These valves utilize a unique, patented ball with a special “characterized” opening that results in the linear flow rate change. Valves are shipped with the ball installed so that the smaller opening enters the flow first, creating the slow open rate. To switch to the fast opening rate, simply reverse the ball in the valve. Then the larger opening will enter the flow first – creating a large opening with slower changes.

Perfect with Positioners

Hayward ProFile2 Proportional Control True Union Ball Valves can be supplied with optional electric or pneumatic actuators with positioners for automated modulating service applications.

Never a Problem with Corrosion

Because of their all-plastic construction, Hayward ProFile2 ball valves will never rust or corrode – and they can survive corrosive environments and harsh weather conditions without the need for painting or expensive epoxy coating.

Applications

- Methane Gas Recovery
- Fill Station Lines
- Lateral Take Off Line Flow Control
- Flow Reduction in Systems with Oversize Pumps
- Control Flow from Tanks

Features

- All-Plastic Construction
- Precise Flow Control
- True Union Design
- Integrally Molded Stem Support and Mounting Platform for Proper Alignment and Actuator Mounting
- Fully Serviceable Internals can be Inspected and Serviced

Options

- Positioners for Automated Modulating Service Applications
- EPDM Seals
- Manual Handle

ProFile2™ is a trademark of Hayward Industrial Products, Inc.
Corzan® is a registered trademark of Noveon, Inc.



Technical Information

Selection Chart

Size	Material	End Conn.	Seals	Pressure Rating
1, 2, 3, 4"	PVC or CPVC	Socket, Threaded or Flanged	FPM or EPDM	250 PSI @ 70°F
6"*	PVC or CPVC	Flanged	EPDM	Non-Shock

Dimensions

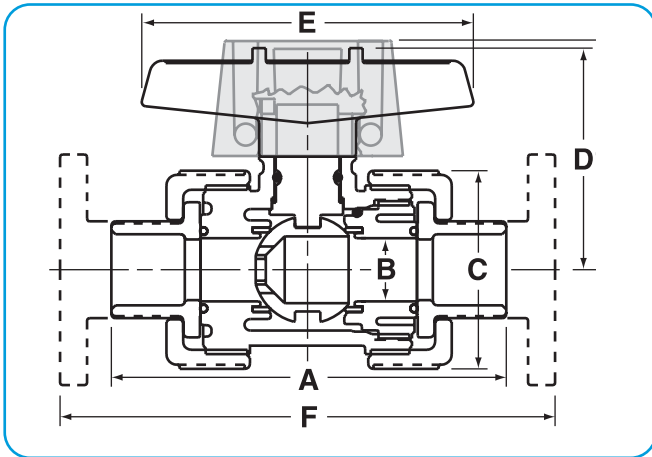

Temperature/Pressure Chart

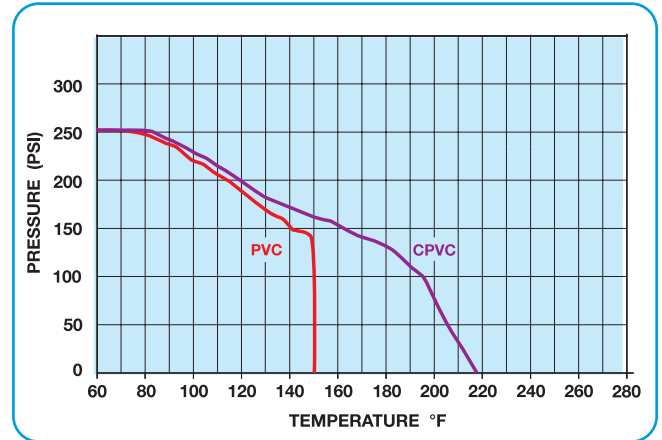

Dimensions

Size	A	B	C	D1	D2	E	F
1"	5.25	1.00	3.00	3.32	3.05	4.00	8.00
2"	8.00	1.83	4.75	4.43	4.00	5.00	11.38
3"	10.56	3.00	6.40	5.50	5.50	10.50	14.44
4"	12.94	3.75	8.56	6.50	6.50	10.50	17.13

Pressure Loss Determination

The charts below are used to determine the flow coefficients for ProFile2 Proportional Control Ball valves. The flow coefficient can be used to calculate the pressure loss across the valve at any angular degree of opening using the formula: **Pressure Loss = (Flow in GPM / Flow Coefficient)²**. For example a 1" valve with a "slow open" configuration that is 60° open has a flow coefficient of 8. If the valve were to be installed in a system with a flow rate of 16 gpm, the **Pressure Loss** would be **(16 / 8)² = 4**. The flow coefficients for standard, full flow valves are shown for comparison.

Angular Deg of Opening	Slow Open	Fast Open	Full Port Valve
15°	0.5	1.0	1.2
30°	1.9	3.4	3.5
45°	3.7	7.0	7.5
60°	8.0	13.0	15.3
75°	14.7	18.8	27.8
90°	21.0	21.0	29.0

Angular Deg of Opening	Slow Open	Fast Open	Full Port Valve
15°	1	2.5	10
30°	4	11	16
45°	11	25	35
60°	21	44	72
75°	37	54	117
90°	56	56	150

Pressure Loss Calculation Formula

$$\Delta P = \left[\frac{Q}{C_v} \right]^2$$

ΔP = Pressure drop

Q = Flow in GPM

C_v = Flow coefficient

Angular Deg of Opening	Slow Open	Fast Open	Full Port Valve
15°	3	10	10
30°	12	26	26
45°	30	50	55
60°	60	79	110
75°	89	112	212
90°	128	128	490

Angular Deg of Opening	Slow Open	Fast Open	Full Port Valve
15°	5	18	38
30°	30	55	90
45°	65	114	165
60°	120	183	250
75°	185	200	458
90°	215	215	600