

FRIALEN®-Repair and Reinforcing Saddles VVS

PE 100 SDR 11

Maximum working pressure 16 bar (Water) / 10 bar (Gas)

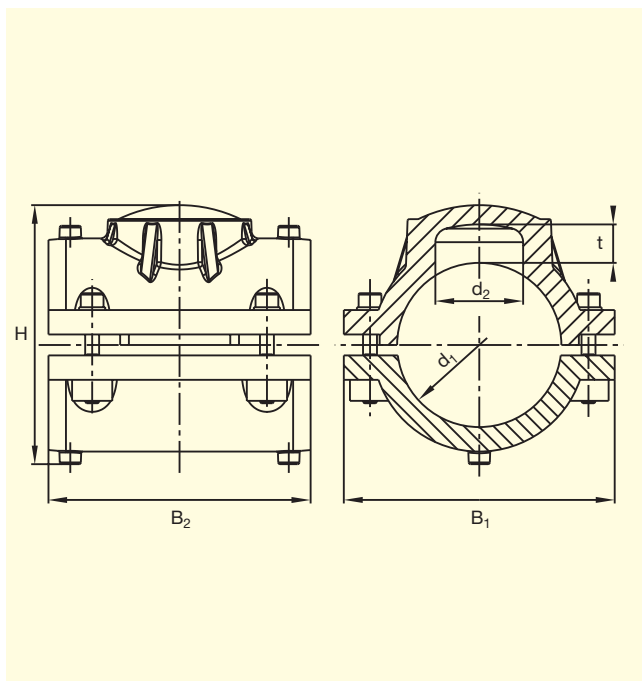

d ₁	d ₂	Order Ref.	Stock-status	VE	PE	B ₁	B ₂	H	t	Weight kg/each
90	50	T-615 164	1	24	192	155	150	148	21	0.920
110	50	T-615 165	1	16	128	175	180	168	21	1.193
125	50	T-615 166	1	15	120	190	185	183	21	1.363
160	50	T-615 168	1	10	80	225	195	218	21	1.666
180	50	T-615 169	1	6	48	240	195	238	21	1.805
200	50	T-615 170	1	5	40	250	195	258	21	1.823
225	50	T-615 171	1	5	40	255	195	283	21	1.874

FRIALEN®-Safety Fittings can be fused to pipes of SDR stages 11 to 17.6
DVGW-Registration No.: DV-8606AU2249

Please turn over for important information regarding application of the
FRIALEN®-Repair and Reinforcing Saddles VVS

FRIALEN[®]-Repair and Reinforcing Saddles VVS

PE 100 SDR 11

Maximum working pressure 16 bar (Water) / 10 bar (Gas)

Areas of Application

The FRIALEN[®]-Repair and Reinforcing Saddles are used for the repair of minor pipe damages.

Assembly Instructions

The fusion of the HD-PE pipe with the FRIALEN[®]-Repair and Reinforcing Saddle takes place by FRIALEN[®]-fusing – leakproof and longitudinally strong.

In order to avoid discharge of media, the leak has to be sealed with a separate plug ($\leq d_2$).

Both HD-PE saddles have to be prepared according to the general installation instructions (see “Assembly Instructions” for “FRIALEN[®]-Safety Fittings for house connections and distribution pipes up to d 225”). This includes removing the oxide layer and cleaning the pipe covered by the saddles.

Six good reasons for using the FRIALEN[®]-VVS

- **Compact construction**
- **HD-PE saddle with exposed heating element for optimal heat transfer**
- **Sealing area free of heating wires**
- **Preassembled unit without loose parts**
- **Extra wide fusion zone**
- **Additional barcode for tracing back the underground (Traceability-Coding).**

Please find our datasheets for downloading on the internet at www.friatec.com

For further information, please call our FRIALEN[®]-customer service and specialist advisers.