

# FRIALEN®-Hot Tapping Tee DAS

## Top-Loading

### PE 80 SDR 11

Maximum working pressure 12.5 bar (Water) / 5 bar (Gas)

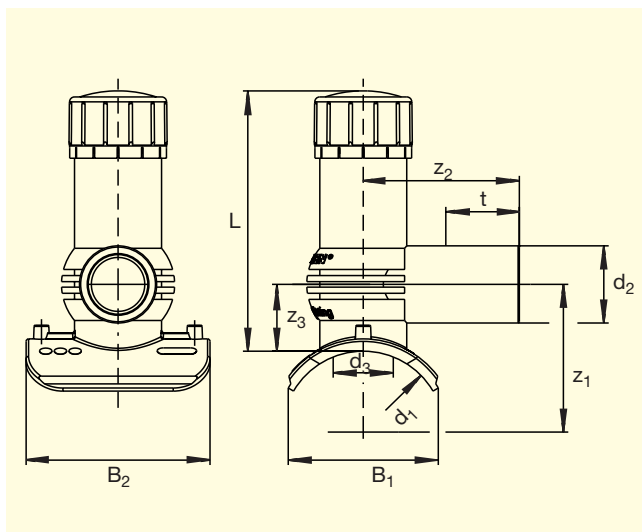

#### Medium Volume (Type 25)

d <sub>1</sub>	d <sub>2</sub>	Order-Ref.	Stock-status	VE	PE	d <sub>3</sub>	Z <sub>1</sub>	Z <sub>2</sub>	Z <sub>3</sub>	B <sub>1</sub>	B <sub>2</sub>	t	L	Weight kg/each
63	32	T-615 797	2	16	288	25	65	108	34	71	120	44	146	0.400
110	32	T-615 781	2	24	192	25	90	108	35	115	150	44	145	0.525
160	32	T-615 788	2	24	192	25	111	108	31	126	150	44	149	0.525

#### High Volume (Type 33, Type 50)

d <sub>1</sub>	d <sub>2</sub>	Order-Ref.	Stock-status	VE	PE	d <sub>3</sub>	Z <sub>1</sub>	Z <sub>2</sub>	Z <sub>3</sub>	B <sub>1</sub>	B <sub>2</sub>	t	L	Weight kg/each
63	63	T-615 804	2	16	288	30	59	150	28	71	120	63	111	0.585
110	63	T-615 789	2	16	96	45	105	160	50	117	150	63	207	1.715
160	63	T-615 792	2	16	96	45	105	160	25	126	150	63	207	1.715

FRIALEN®-Hot Tapping Tee DAS can be used for pipes of SDR stages 11 to 17.6

For installation of DAS Type 25, 33 and 50 the Installation Set DAS is required  
Order-Ref.: T-613 340

Please turn over for important information regarding application of the  
**FRIALEN®**-Hot Tapping Tees DAS.

# **FRIALEN<sup>®</sup>-Hot Tapping Tee DAS**

## **Top-Loading**

### **PE 80 SDR 11**

Maximum working pressure 12.5 bar (Water) / 5 bar (Gas)

## **Areas of Application**

The FRIALEN<sup>®</sup>-DAS Hot Tapping Tees are used for branches of unpressurised and pressurised gas and water pipelines.

## **Assembly Instructions**

The fusion of the HDPE distribution pipes and the house connections with FRIALEN<sup>®</sup>-Hot Tapping Tees takes place by FRIALEN<sup>®</sup>-fusing – leakproof and longitudinally strong.

The saddle and the outlet spigot have to be prepared according to the general installation instructions (see „Assembly Instructions“ „FRIALEN<sup>®</sup> DAS Hot Tapping Tees“).

Component is clamped onto the pipe using the DAS installation tool.

## **Ten good reasons for using the FRIALEN<sup>®</sup> DAS**

- **Compact design**
- **Installation without rerounding clamps, no underclamps required**
- **Easy installation with DAS installation tool**
- **High-volume tapping with extra large drill  $\varnothing$  25,  $\varnothing$  30 and  $\varnothing$  45 mm**
- **Pressure test possible before tapping**
- **Swarfless tapping**
- **Punched-out pipe piece fits securely in drill**
- **Drill with upper and lower stop**
- **Extra wide fusion zone**
- **Length of outlet spigot dimensioned for two fusion operations**

Please find our datasheets for downloading on the internet at [www.friatec.com](http://www.friatec.com)

**For further information, please call our FRIALEN<sup>®</sup>-customer service staff and specialist advisers.**