

## FRIAFIT® USTZ adapter

For the connection of stoneware pipes with a FRIAFIT® AM coupler or a FRIAFIT® ASA-TL sewage saddle, for HD-PE pipes SDR 33 – SDR 17

**PE 100**

Maximum test pressure 0.5 bar (according to DIN EN 1610)

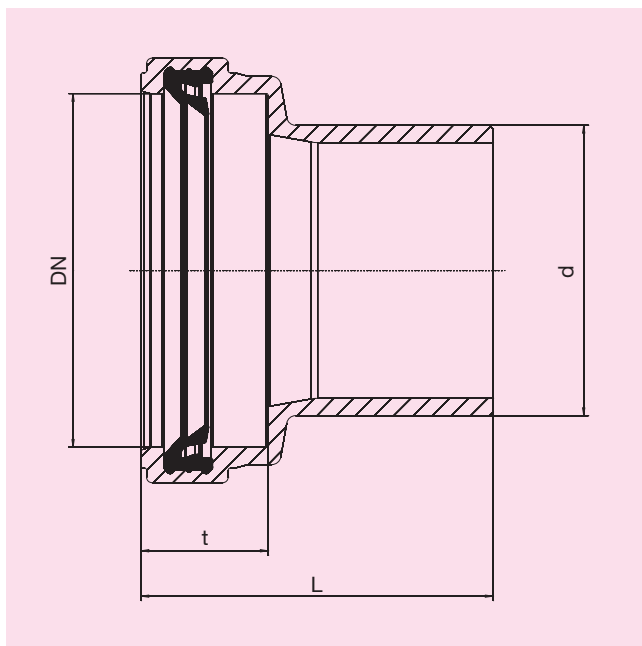

d/DN	Order Ref.	Stock-status	VE	PE	L	t	Weight kg/each
160/150	T-682 623	1	2	36	194	70	1.250

Please turn over for important information regarding **FRIAFIT®**-Transition Fitting USTZ.

# FRIAFIT® USTZ adapter

**For the connection of stoneware pipes with a FRIAFIT® AM coupler or a FRIAFIT® ASA-TL sewage saddle, for HD-PE pipes SDR 33 – SDR 17 PE 100**

Maximum test pressure 0.5 bar (according to DIN EN 1610)

Sewage pipe systems represent top quality economic goods with a value which needs to be maintained for a long time. Increasing demands made on public sewage system require materials which meet these criteria. For many years HD-PE sewage pipes have been welded using the FRIAFIT® HD-PE sewage system – tight, with axial force and perfectly rooted.

## Areas of application

The FRIAFIT® USTZ adapter serves as a smooth connection between HD-PE pipes (wall thickness ratio from SDR 33 to SDR 17) and stoneware pipes in service connections.

## Advice on processing

Welding the spigot part of the USTZ adapter with a FRIAFIT® AM d 160 coupler or a FRIAFIT® ASA-TL sewage saddle, d 160 outlet, takes place using the FRIAFIT® fusion method – tight and with axial force.

The USTZ spigot part is prepared (remove oxidic layer/clean) according to the general installation instructions (see “installation instructions” for the FRIAFIT® sewage system).

The stoneware pipe is inserted into the side where the push-fit coupler sits. The push-fit coupler has a SBR lip seal gasket and a large insertion depth for safe guidance of the pipe.

**For further information, please call our FRIALEN®- and FRIAFIT®- customer service and specialist personnel.**

## Seven good reasons for the FRIAFIT® USTZ adapter

### Spigot part

- Safeguards tight and perfectly rooted connection with axial force
- FRIAFIT® fusion for the connection of USTZ with AM coupler or ASA-TL service saddle.
- Smooth connection between materials when using HD-PE SDR 33 – SDR 17 pipe, no deposit in the area of the joint, no flow obstruction

### Push-fit part

- Safe guidance of the stoneware pipe due to large insertion depth
- SBR lip seal gasket according to EN 681-1
- Standardised connection between materials
- Simple assembly of stoneware pipes

Please find our datasheets for downloading on the internet at [www.friatec.de](http://www.friatec.de)