

SARTELL Valves, Inc.

DeZURIK Water
Controls

SARTELL Valves &
Controls

G-SERIES ROTARY CYLINDER ACTUATORS



Design and Construction

Sartell Valves, Inc. offers G-Series cylinder actuators for use on DeZURIK Water Controls and Sartell Valves & Controls eccentric plug valves (PEC). They're available in a double-acting style, either pneumatic or hydraulic supply.

G-Series cylinder actuators feature a rack-and-gear design for larger size rotary valves, where constant high torque capability throughout the stroke is required. It is engineered for high-flow, high-cycle applications. The G-Series line of actuators provides long service life and features a rugged, heavy cast gear sector.

Enclosed Actuator Housing

The cast iron actuator housing on G-Series actuators is sealed to prevent the entry of dirt, moisture and corrosive contaminants.

Adjustable Position Stops

G-Series actuators feature adjustable position stops in both the open and closed positions.

Rugged Cylinder Construction

Cylinder construction includes a rugged cast piston with combination seal and guide ring of PTFE.

Corrosion-Resistant Bearings

G-Series actuators feature multiple bronze and stainless steel bearings that provide support and minimize friction to assure smooth operation and throttling action.

Accessories

Cylinder actuators are available with a variety of accessories including positioners, manual overrides and solenoid valves.

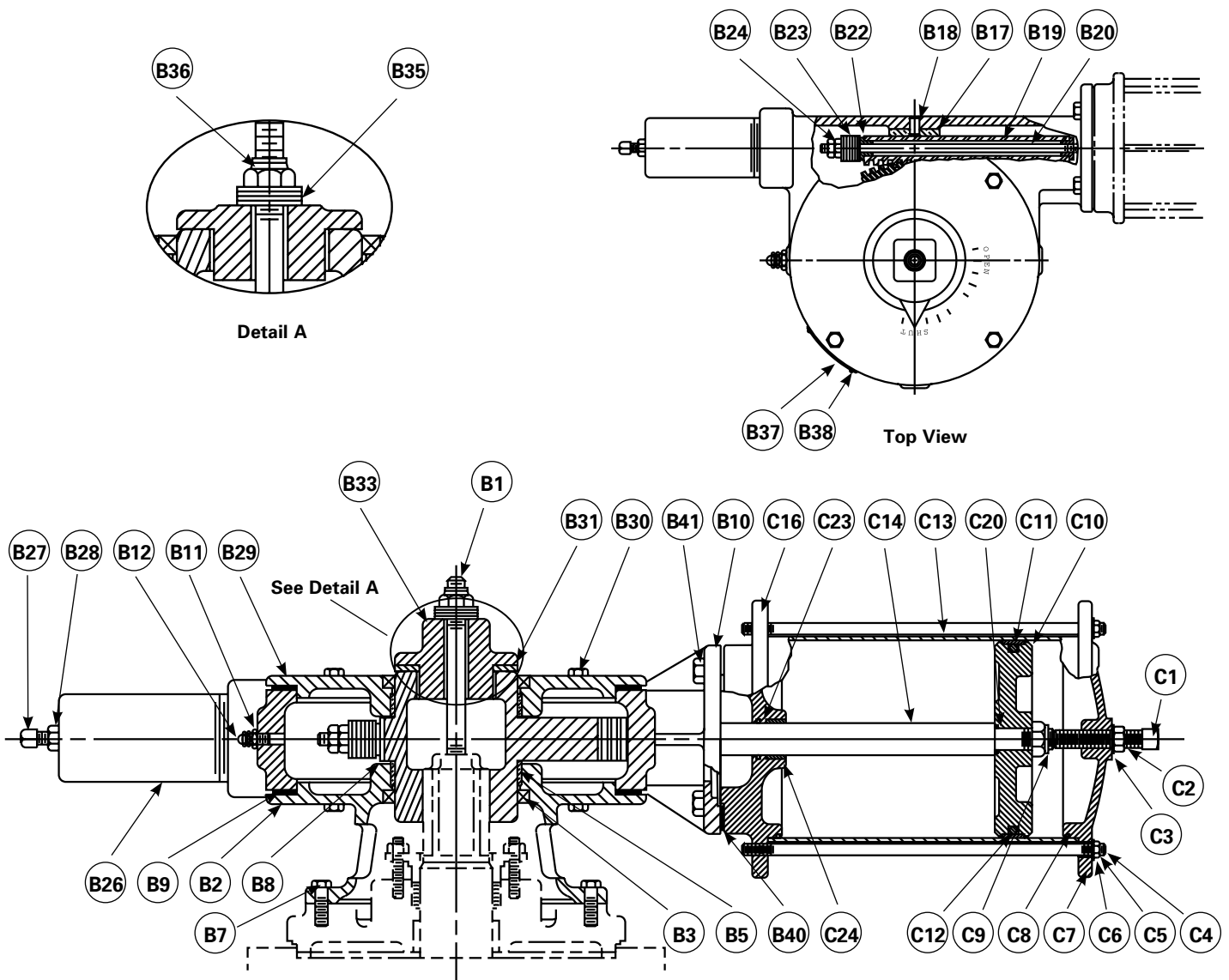

Actuator Weights

Actuator Size	Weight Lbs. (Kgs)
GS-6-PC4	95 (43)
GS-6-PC6	103 (47)
GS-6-PC8	130 (59)
GS-12-PC6	240 (109)
GS-12-PC8	260 (118)
GS-12-PC10	320 (145)
GS-16-PC10	395 (179)
GS-16-PC12	520 (236)

Materials of Construction

Item	Description	Material
B1	Stud	Steel Zinc Plated
B2	Adapter	Cast Iron ASTM A126 Class B
B3	Seal (Gear Sector)	Steel with Nitrile
B5	Bearing	Bronze Oil Impregnated
B7	Screw	Steel Zinc Plated
B8	Gear Sector	Ductile Iron ASTM A536 80-55-06
B9	Gasket (Housing)	Nonasbestos Compressed
B10	Housing	Cast Iron ASTM A126 Class B
B11	Bushing	Brass
B12	Vent Plug	Steel Zinc Plated
B17	Rack Bearing	Bronze ASTM B427
B18	Pin	Steel Zinc Plated
B19	Rack	Steel AISI 1018
B20	Rack Rod	Steel
B22	Bearing	Bronze Oil Impregnated
B23	Spring Washer	Steel
B24	Jam Nut	Steel Zinc Plated
B26	Extension Cap	Steel AISI 1018
B27	Set Screw	Steel Zinc Plated
B28	Jam Nut	Steel Zinc Plated
B29	Cover	Cast Iron ASTM A126 Class B
B30	Screw	Steel Zinc Plated
B31	Pointer	12 Gauge SAE 1010 Zinc Plated
B33	Wrenching Square	Cast Iron ASTM A126 Class B
B35	Spring Washer	Steel Zinc Plated
B36	Lock Nut	Steel Zinc Plated
B37	Data Plate	Stainless Steel Type 302
B38	Drive Screw	Steel Cadmium Plated
B40	Gasket	Nonasbestos Compressed
B41	Screw	Steel Zinc Plated
C1	Set Screw	Steel Zinc Plated
C2	Jam Nut	Steel Zinc Plated
C3	Seal Thread	Steel with Nitrile
C4	Tie Rod	Steel AISI C1018 Zinc Plated
C5	Nut	Steel Zinc Plated
C6	Lock Washer	Steel Zinc Plated
C7	Cylinder Cap	Ductile Iron ASTM A536 65-45-12
C8	O-Ring	Nitrile (NBR)
C9	Lock Nut	Steel Zinc Plated
C10	Piston	Cast Iron ASTM A126 Class B
C11	Piston Seal	Virgin Teflon
C12	O-Ring	Nitrile (NBR)
C13	Cylinder Tube	Fiberglass
C14	Piston Rod	Steel AISI C-1141 Chrome Plated
C16	Cylinder Head	Cast Iron ASTM A126 Class B
C20	O-Ring	Nitrile (NBR)
C23	Rod Seal	Teflon with Nitrile
C24	Bearing	Bronze Oil Impregnated

Actuator Mounting

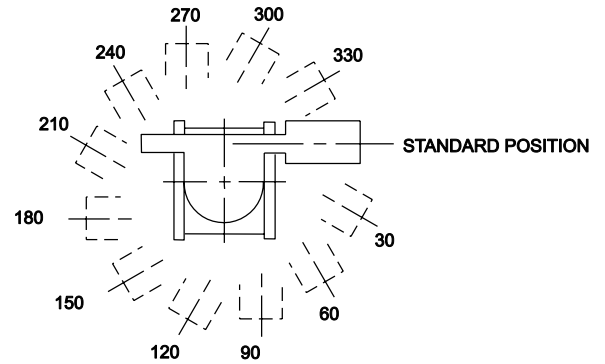

Dimensions

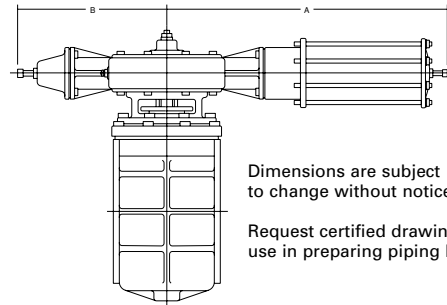

Dimensions are subject to change without notice.

Request certified drawing for use in preparing piping layouts.

PEC

Actuator Model	Dimensions	
	A	B
GS-6-PC4	18.88	11.00
	480	279
GS-6-PC6	19.12	11.00
	486	279
GS-6-PC8	19.38	11.00
	492	279
GS-12-PC6	30.56	17.50
	776	445
GS-12-PC8	30.88	17.50
	784	445
GS-12-PC10	31.00	17.50
	787	445
GS-16-PC8	42.62	24.25
	1083	616
GS-16-PC10	43.25	24.25
	099	616
GS-16-PC12	44.62	24.25
	1133	616

Ordering

To order a G-Series rotary cylinder actuator, select the actuator model from the appropriate valve style sizing charts. Specify mounting position other than standard as second line information. As a reference, the actuator code is defined as follows:

Double-Acting

Cylinder Type

GS = G-series Actuator

Gear Size

6 = 6" (150mm)

12 = 12" (300mm)

16 = 16" (400mm)

Cylinder Size

PC4 = 4" (100mm) Diameter pneumatic cylinder

PC6 = 6" (150mm) Diameter pneumatic cylinder

PC8 = 8" (200mm) Diameter pneumatic cylinder

PC10 = 10" (250mm) Diameter pneumatic cylinder

PC12 = 12" (300mm) Diameter pneumatic cylinder

Ordering Example:

PEC,20,F1,CI,NBR,CR*GS-12-PC8

Actuator mounted 90° from standard.

Sales and Service

For information about our worldwide locations, approvals, certifications and local representative:

Web Site: www.sartellvalves.com E-Mail: info@sartellvalves.com

SARTELL Valves, Inc.



250 Riverside Ave. N. Sartell, Minnesota 56377 • Phone: 320-259-2000 • Fax: 320-259-2227

Sartell Valves, Inc. reserves the right to incorporate our latest design and material changes without notice or obligation. Design features, materials of construction and dimensional data, as described in this bulletin, are provided for your information only and should not be relied upon unless confirmed in writing by Sartell Valves, Inc. Certified drawings are available upon request.

Printed in the U.S.A.