



P440F Flanged Swing Check Valves

BODY MATERIALS: PVC

SIZES: 1/2" to 6"

END TYPES: Flanged

TEST PRESSURE: 225 PSI

WORKING PRESSURE: 150 PSI

Check Valves	Body	Style	Ends	Seat	Seals
P440F	Schd 80 PVC	Swing Check	Flanged	PTFE	EPDM



- Corrosion resistant.
- Full flow design.
- Angle seat and weighted flapper design for low pressure seal.

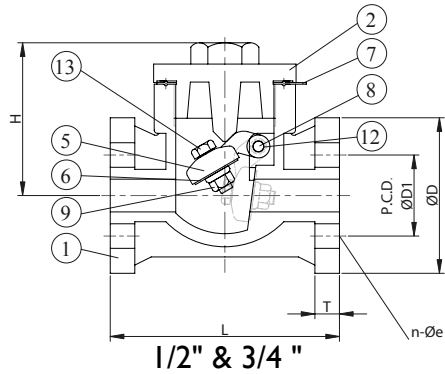

1/2" & 3/4"

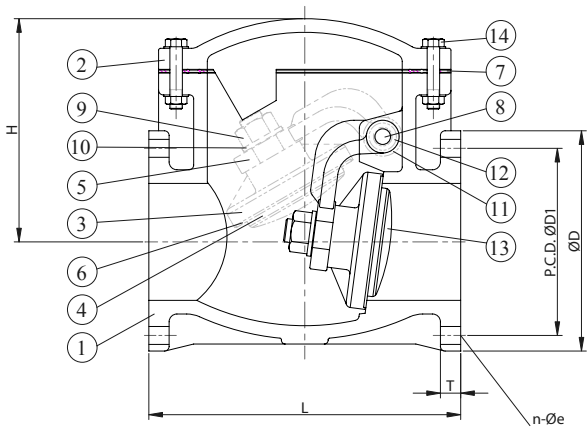

1" - 6"

NO.	PART	MATERIAL	Q'TY
1	BODY	PVC, CPVC, PP, PVDF	1
2	BONNET	PVC, CPVC, PP, PVDF	1
3	DISC	PVC, CPVC, PP, PVDF	1
4	DISC HOLDER	PVC, CPVC, PP, PVDF	1
5	SWAY ARM	PVC, CPVC, PP, PVDF	1
6	DISK GASKET	EPDM, NBR, FPM	1
7	GASKET	EPDM, NBR, FPM	1
8	SHAFT	PVC, CPVC, PP, PVDF	1
9	DISK NUT	PVC, CPVC, PP, PVDF	1
10	DISK WASHER	PVC, CPVC, PP, PVDF	1
11	SHEET GASKET	EPDM, NBR, FPM	1
12	SHEET BOLT	PVC, CPVC, PP, PVDF	1
13	DISC BOLT	PVC, CPVC, PP, PVDF	4
14	BOLT SETS	STEEL, SUS 304	8-12

SIZE		15mm	20mm	25mm	32mm	40mm	50mm	65mm	80mm	100mm	150mm	200mm
Nom.		(1/2")	(3/4")	(1")	(1-1/4")	(1-1/2")	(2")	(2-1/2")	(3")	(4")	(6")	(8")
n-Øe	JIS	4-Ø15	4-Ø15	4-Ø19	4-Ø19	4-Ø19	4-Ø19	4-Ø19	8-Ø19	8-Ø19	8-Ø23	8-Ø23
	ANSI	4-Ø16	4-Ø16	4-Ø16	4-Ø16	4-Ø16	4-Ø19	4-Ø19	4-Ø19	8-Ø19	8-Ø22	8-Ø22
	DIN	4-Ø14	4-Ø14	4-Ø18	4-Ø18	4-Ø18	4-Ø18	4-Ø18	4-Ø18	8-Ø18	8-Ø23	8-Ø23
L	JIS	140	140	160	160	180	200	240	260	300	400	500
	ANSI	140	140	160	160	180	200	240	260	300	400	500
	DIN	140	140	160	160	180	200	240	260	300	400	500
D	JIS	100	100	125	125	140	155	175	185	210	285	330
	ANSI	100	100	108	108	127	152	178	191	229	285	343
	DIN	100	100	115	115	150	165	185	200	220	285	343
D1	JIS	70	75	90	100	105	120	140	150	175	240	290
	ANSI	60	70	79	88.9	98	121	140	152	191	241	298
	DIN	65	75	85	100	110	125	145	160	180	240	295
T		15	15	17	17	19	20	22	22	24	26	30
H		93	93	117.5	117.5	136	166	170.5	170	216	286	336

AMERICAN VALVE STATEMENT OF WARRANTY & LIMITATION OF WARRANTY

American Valve warrants, to its initial purchaser only, that its products which are delivered to this initial purchaser will be the kind described in the order or price list and will be free of defects in workmanship or material for a period of one year from the date of delivery to you, our initial purchaser.

Should any failure to conform to this warranty appear within one year after the date of the initial delivery to our initial purchaser, American Valve will, upon written notification thereof and substantiation that the goods have been stored, installed, maintained and operated in accordance with American Valve's recommendation and standard industry practice, correct such defects by suitable repair or replacement at American Valve's own expense. If any valve alleged to be defective, is returned to our factory at Greensboro, NC, it will be examined and, if found to be defective under the warranty, it will be replaced at no charge.

THIS WARRANTY IS EXCLUSIVE AND IS IN LIEU OF ANY IMPLIED WARRANTY OF MERCHANTABILITY, FITNESS FOR A PARTICULAR PURPOSE OR OTHER WARRANTY OF QUALITY, WHETHER EXPRESS OR IMPLIED, EXCEPT THE WARRANTY OF TITLE AND AGAINST PATENT INFRINGEMENT. Correction of non-conformities, in the manner and for the period of time provided above, shall constitute fulfillment of all liabilities of American Valve to our initial purchaser, with respect to the goods, whether based on contract, negligence, strict tort or otherwise, it is the intention of American Valve that no warranty of any kind, whether express or implied, shall pass through our initial purchaser to any other person or corporation.

LIMITATION OF LIABILITY: American Valve SHALL NOT UNDER ANY CIRCUMSTANCES BE LIABLE FOR SPECIAL OR CONSEQUENTIAL DAMAGES SUCH AS, BUT NOT LIMITED TO, DAMAGES OR LOSS OF OTHER PROPERTY OR EQUIPMENT, LOSS OF PROFITS, OR REVENUE, COST OF CAPITAL, COST OF PURCHASED OR REPLACEMENT GOODS, OR CLAIMS OF CUSTOMERS OF OUR INITIAL PURCHASER. THE REMEDIES OF OUR INITIAL PURCHASER, AND ALL OTHERS, SET FORTH HEREIN ARE EXCLUSIVE, AND THE LIABILITY OF AMERICAN VALVE WITH RESPECT TO SAME SHALL NOT, EXCEPT AS EXPRESSLY PROVIDED HEREIN, EXCEED THE PRICE OF GOODS UPON WHICH SUCH LIABILITY IS BASED.



P.O. Box 35229
Greensboro, NC 27425
Phone: 1-800-645-0101
Fax: 1-800-876-0109
<http://www.AmericanValve.com>