

Replace Obsolete Gate Valves



Model 3700 Ball Valve

In the past there were compromises. Ball valves used to be so expensive. American Valve's Model 3700 Cast Iron Ball Valve finally provides a quality solution without compromise.

Our Teflon®-fused ball eliminates ball pitting, prevents buildup, lowers torque, and stops premature valve failure. And since the Teflon® is impregnated .008" into the metal, it can't wear, chip, or flake. Model 3700 features an epoxy-coated body with tapped and plugged boss, making it ideal for liquid, air, or backflow applications.

Model 3700 offers bubble-tight class VI positive shutoff and many years of trouble-free operation.

- ▶ Same end-to-end dimensions as any flanged gate valve
- ▶ Easily outperforms, outlasts any gate or butterfly valve
- ▶ Full-port
- ▶ Rated 200W @ 200° F
- ▶ Available in 2-8"
- ▶ 100% lead-free: Meets NSF 61-8 and California Prop. 65

American Valve, Inc.
P.O. Box 35229
Greensboro, NC 27425
Toll-Free: 1-800-645-0101
www.americanvalve.com
sales@americanvalve.com

Teflon® is a registered trademark of DuPont



Model 3700 Ball Valve At A Glance

The basic gate valve design has been used at least since the age of Roman aqueducts and the invention of indoor plumbing. No significant advances were made until the development of quarter-turn ball valves in the 1950's. Over time, the market for bronze and brass ball valves has easily eclipsed gate valves. People quickly recognized the benefits of ball valves and the problems endemic to gate valves. But unlike similar threaded bronze valves, larger sized flanged-end ball valves were impractical replacements for iron gate valves because of stainless steel designed for the petroleum industry, which requires API 607 fire-safe features for flammable petroleum handling. No accommodation was made to address 90% or all valve applications (water and air), where API 607 is not required.

American Valve model 3700 provides the first affordable alternative to gate valves, exactly matching their end-to-end and flanged dimensions.

Some key advantages of 3700 ball valves are:

- Quarter turn provides instant shutoff.
- Full unobstructed flow
- Easy to open and close. No cheater bar required.
- Positive shutoff: Exceeds the requirements of ANSI Class 6
- No bronze seat rings, bronze disc rings, or bronze stems to wear out or leach.
- Lighter than gate valves, making installation and handling easier.
- Handle shows whether open or closed.
- Ball wipes clean during opening and closing.
- No bronze parts allows for use in all-iron gate valve applications.
- Compact design fits into areas of limited space.
- Low profile design and packaging enables easier storage and shipping.
- Can be locked in either open or closed position.
- Teflon®-fused ball resists corrosion in wider range of applications.
- Zero wear rate in the open position.
- Epoxy-coated body inside and outside.



Gate Valves...

- Are designed for a class 4 shutoff, which allows for a hefty leak rate from day one.
- Get harder to turn over time, since the disc and seats are exposed to buildup and corrosion.
- Lose their seating ability over time, because the seat rings are always exposed to downstream flow corrosion when the valve is in the open position.
- Are generally unreliable in applications requiring positive shutoff for isolation or safety purposes.

On the other hand, Ball valves work much better because...

- The main seating surfaces are fully protected in the open position
- They're made to a higher, class 6 closing standard.
- They're quarter-turn, which not only provides for convenient operation, but also a positive visual indication of whether the valve is open or closed.

Unlike other types of valves, model 3700 is designed to maintain a bubble-tight shut-off that exceeds ANSI Class VI for many years, even if the valve has not been operated or maintained regularly.

All model 3700 valves are rated at 200 psig @ 200°F, and are full port from sizes 2" through 8".

Model 3700 features Teflon® seats and EPDM seals. It should not be used in steam, oil, or flammable gas applications, but is ideally suited for potable water, wastewater, or other liquids and compressed air.

Model 3700 has no bronze parts, which contain Lead. As regulatory agencies continue to reduce the allowable Lead content of components in our drinking water supply, Model 3700 offers a safe alternative to IBBM gate valves.

Model 3700 is bi-directional; flow may go in either direction. It may be mounted horizontally, vertically, or at an angle. Model 3700 may be locked in either the open or closed position. 2" square operating nuts are available for underground service or hard-to-reach installations. Gear operators and actuators are available with an upgrade to our 4000 series ball valve.



MODEL 3700 BALL VALVE



- ▶ Epoxy Coated Cast Iron Body.
- ▶ Teflon®-fused Solid Ball.
- ▶ Same end-to-end as any flanged gate valve.
- ▶ Tapped & plugged boss allows for venting or draining downstream.
- ▶ 2" through 8" - Full Port.
- ▶ Rated 200W @ 200°F.
- ▶ Class VI Positive Shutoff.
- ▶ 100% Lead-Free.
- ▶ Low Torque.
- ▶ Ideal for Liquid, Air, and Backflow applications.

AMERICAN VALVE'S PATENTED TEFLON-FUSED BALL

Model 3700 features the fusion process developed by American Valve over 10 years ago.

This feature eliminates ball pitting, prevents build-up, lowers torque, and stops premature valve failure.

Since the Teflon® is actually impregnated .008" into the metal, it can't wear, chip, or flake.

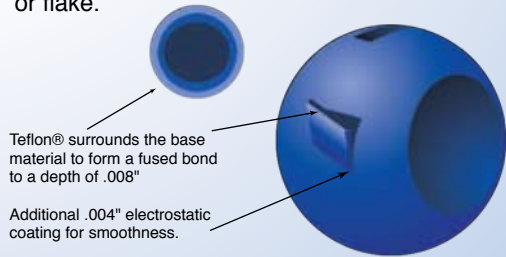

Additional .004" electrostatic coating for smoothness.

Together they produce the strength of steel with the corrosion resistance of Teflon®. Our patented process has gained the best of both worlds...Strength, Lubricity, and Bonding.

Materials

No.	Part	Material
1	Body	Cast Iron
2	Ball	Cast Iron / Teflon Fused
3	Stem	Stainless Steel
4	Gland Plate	Steel
5	Handle	Steel
6	Packing Follower	Stainless Steel
7	Fasteners	Steel/Zinc Plated
8	Packing O-Rings	EPDM
9	Body Gasket O-Rings	EPDM
10	Seat Rings	RPTFE-15% Glass Filled
11	Handle Grip	Vinyl

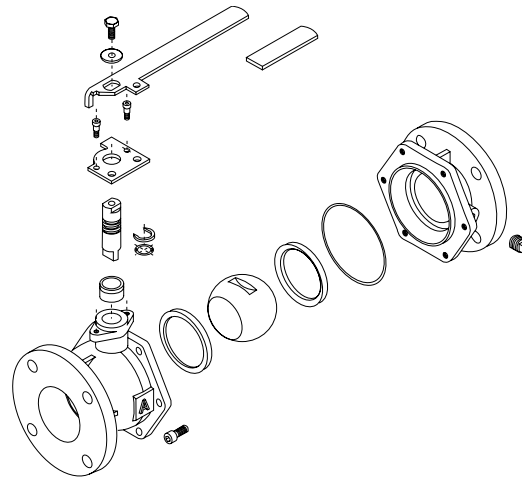

Meets California Prop. 65
61 < 5
Drinking Water Standards

Dimensions - Weights

		2	2 1/2	3	4	6	8
A	Face to Face	7	7 1/2	8	9	10 1/2	11 1/2
B	Center of Port to Top	5 1/2	6	6 3/8	7 1/8	8 7/8	10 3/8
C	Flange Diameter	6	7	7 1/2	9	11	13 1/2
D	Center of Valve to Handle End	12	10 1/8	10 7/8	12 5/8	16 3/4	19 3/4
	Port Diameter	2	2 1/2	3	4	6	8
	Bolt Holes	4	4	4	8	8	8
	Weight (lbs.)	22	27	35	56	113	194

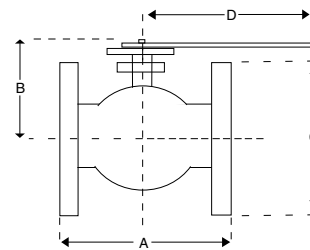

* Teflon® is a registered trademark of DuPont

The Tale of the Tape



Typical Gate Valve

VS.



Model
3700
Ball Valve®

▼ Class IV **Allowable Leak-Rate**

▼ Same End-to-End Dimensions as Model 3700 (ANSI B16.10)

▼ **Unprotected Metal Gate—**
Notorious as a magnet for buildup and mineral deposits, making full shutoff impossible. Should come with a cheater bar.

▼ **Heavy & Awkward**
- Requires "Big Joe" to Install

- Typical 3" Gate Valve = 72 lbs.
- Typical 6" Gate Valve = 197 lbs.

▼ Contains Bronze parts
...which **contain Lead.**
(Lead has been shown to cause birth defects and damage to the nervous system- even in small doses)

▲ **Positive Shutoff** - Exceeds Class VI

▲ Same End-to-End Dimensions as Class 125 or 150 Gate Valve (ANSI B16.10)

▲ **Teflon®-Fused Ball-**
Prevents Calcium, Lime, or any other buildup common in water applications, which often leads to premature valve failure.

▲ **Lightweight & Compact**
- Easy to Install

- 3" 3700 = 35 lbs.
- 6" 3700 = 113 lbs.

▲ **100% Lead-Free**
-No bronze parts



Teflon® is a registered trademark of DuPont