

SALES & ENGINEERING DATA

650943-XXX-B TWO - BALL PUMP

RATIO
SERIES: **1.7:1**

FLUID P.S.I.
RANGE: **85 - 2040**

RELEASED: 9-20-01
REVISED: 11-14-06
REV. 03 S-1249

DIMENSIONAL DATA

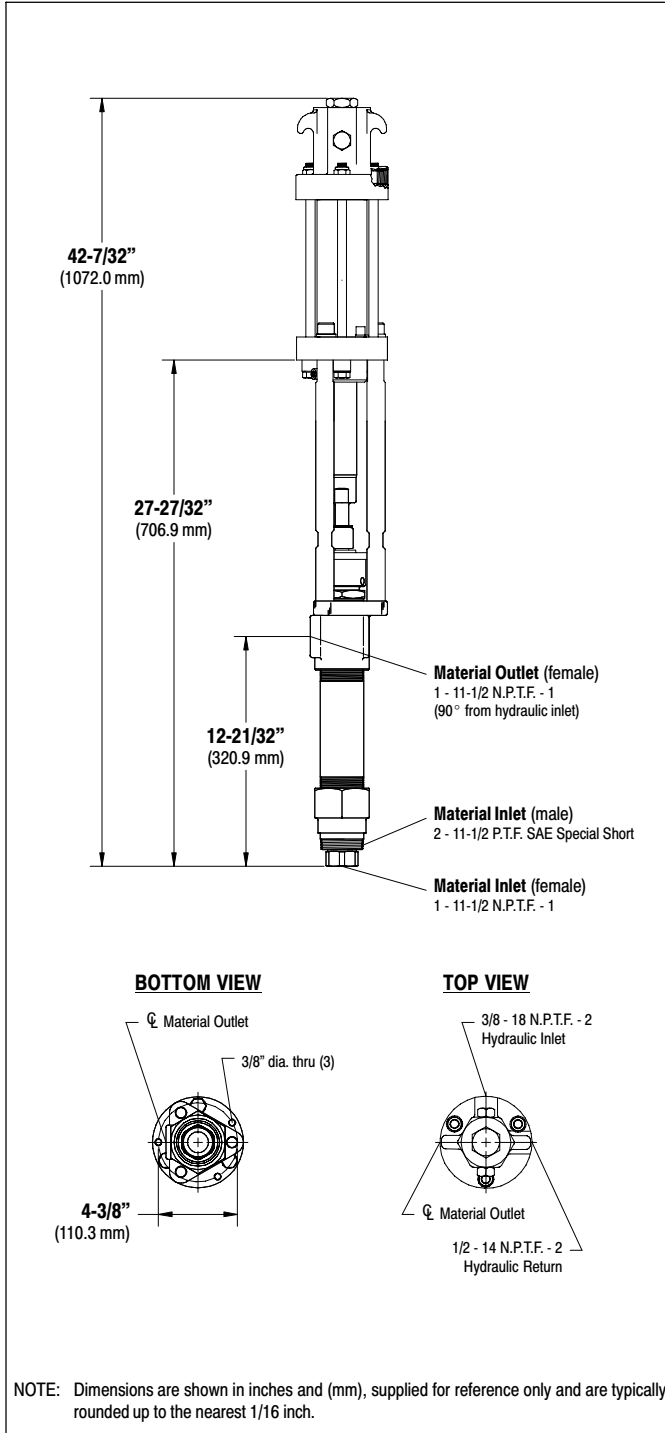

SPECIFICATIONS

CONSTRUCTION

Model Series (refer to option chart)	650943-XXX-B
Pump Type	Hydraulically Operated, Two-Ball, Double Acting Pump
Ratio	1.7:1
Hydraulic Motor	67147-B
Motor Repair Kit	637449
Motor Size	2.062 sq." (13.3 sq. cm)
Stroke	6" (15.2 cm)
Hydraulic Inlet (female)	3/8 - 18 N.P.T.F. - 2
Hydraulic Return (female)	1/2 - 14 N.P.T.F. - 2
Lower Pump End Series	66300-XXX
Lower Pump Repair Kit	637305-X43
Packing Options:	

3 - Glass filled Teflon
C - UHMW-PE
G - UHMW-PE / Leather staggered
P - UHMW-PE / Glass filled Teflon staggered upper • UHMW-PE lower
R - Glass filled Teflon / UHMW-PE staggered upper • Glass filled Teflon lower

Material Inlet (female)	1 - 11-1/2 N.P.T.F. - 1
(male)	2 - 11-1/2 P.T.F. SAE spec. short
Material Outlet (female)	1 - 11-1/2 N.P.T.F. - 1

MATERIALS OF CONSTRUCTION

Outlet Body	CF-8M Stainless Steel
Cylinder (650943-XX3-B)	316 SS, Hard Chrome
(650943-XXB-B)	316 SS, Ceramic coated
Plunger (650943-XX3-B)	17-4 SS, Hard Chrome
(650943-XXB-B)	17-4 SS, Ceramic coated
Upper Ball (650943-X4X-B)	316 Stainless Steel
(650943-X7X-B)	440 Stainless Steel
Upper Seat	Tungsten Carbide
Lower Ball (650943-X4X-B)	316 Stainless Steel
(650943-X7X-B)	440 Stainless Steel
Lower Seat	Tungsten Carbide
Inlet Body	CF-8M Stainless Steel
Weight	41.3 lbs (18.7 kgs)

PERFORMANCE

Hydraulic Inlet Pressure Range	50 - 1200 p.s.i. (3.4 - 82.8 bar)
Fluid Pressure Range	85 - 2040 p.s.i. (5.9 - 140.7 bar)
Required H-power @ 50 c.p.m.	3.2 @ 1200 p.s.i. (82.8 bar)
Hydraulic flow required @ 50 c.p.m.	4.9 g.p.m. (18.5 l.p.m.)
Maximum rec'd Cycles / Minute	50
Displacement In³ Per Cycle	14.5
Volume / Cycle	8.0 oz. (237.5 ml)
Cycles Per Gallon	15.9
Flow @ 50 Cycles / Minute	3.1 g.p.m. (11.9 l.p.m.)
Noise Level	N / A
Maximum Temperature Limit	130° F (54° C)

ACCESSORIES:

67069 Wall Mount Bracket

INGERSOLL RAND COMPANY LTD
P.O. BOX 151 • ONE ARO CENTER • BRYAN, OHIO 43506-0151

☎ (800) 276-4658 • FAX (800) 266-7016 ©2006 CCN 15268931



PERFORMANCE CURVES

