

SALES & ENGINEERING DATA

RATIO SERIES: **13:1**

FLUID P.S.I. RANGE: **390 - 1900**

650871-XXE-C EXTRUSION PUMP

RELEASED: 9-27-01
REVISED: S-1019

DIMENSIONAL DATA

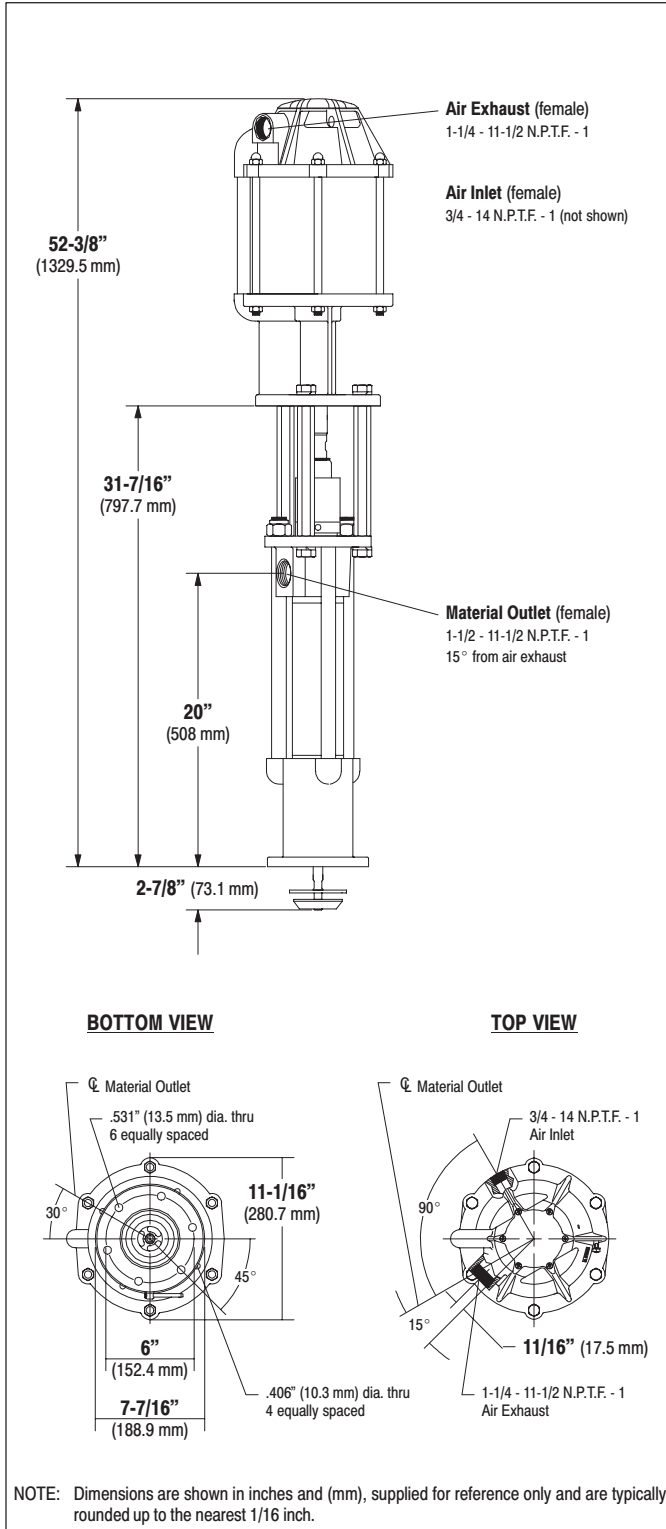

SPECIFICATIONS

CONSTRUCTION

Model Series (refer to option chart)	650871-XXE-C
Pump Type	Air Operated, Extrusion, Double Acting Pump
Ratio	13:1
Air Motor	66523-B
Motor Repair Kit	66614
Motor Diameter	8" (203.2 mm)
Stroke	6" (152.4 mm)
Air Inlet (female)	3/4 - 14 N.P.T.F. - 1
Air Exhaust (female)	1-1/4 - 11-1/2 N.P.T.F. - 1
Lower Pump End Series	66236-XXE-B
Lower Pump Repair Kit	637128-XX4-B
Packing Options:	

3 - Glass Filled Teflon
C - UHMW-PE
F - UHMW-PE / Leather staggered upper • UHMW-PE lower
J - Polyurethane upper • UHMW-PE lower
P - UHMW-PE / Glass Filled Teflon staggered upper • UHMW-PE lower
R - Glass Filled Teflon / UHMW-PE staggered upper • Glass Filled Teflon lower

Material Outlet (female) 1-1/2 - 11-1/2 N.P.T.F. - 1

MATERIALS OF CONSTRUCTION

Outlet Body	Ductile Iron, E Nickel plated
Cylinder	Carbon Steel, Nickel plated
Plunger	Carbon Steel, Chrome plated
Upper Check	440 Stainless Steel
Upper Seat	440 Stainless Steel
Lower Check	440 Stainless Steel
Lower Seat	440 Stainless Steel
Inlet Body	Malleable Iron, Nickel plated
Weight	125.5 lbs (56.9 kgs)

PERFORMANCE

Air Inlet Pressure Range	30 - 120 p.s.i. (2.1 - 8.3 bar)
Fluid Pressure Range	390 - 1900 p.s.i. (26.9 - 131.0 bar)
Maximum Rec'd Cycles / Minute	70
Displacement In³ Per Cycle	40.4
Volume / Cycle	22.4 oz. (661.8 ml)
Cycles Per Gallon	5.7
Flow @ 70 Cycles / Minute	12.2 g.p.m. (46.3 l.p.m.)
Noise Level @ 60 p.s.i. - 40 c.p.m.	89.8 db(A)①

① Tested with 92460 Muffler installed. The pump sound pressure level has been updated to an Equivalent Continuous Sound Level (L_{Aeq}) to meet the intent of ANSI S1.13-1971, CAGI-PNEUROP S5.1 using four microphone locations.

ACCESSORIES:

- 66542 Wall Mount Bracket
- 67187-1 Mounting Post
- 92460 Silencer



PERFORMANCE CURVES

