

SALES & ENGINEERING DATA

RATIO SERIES: **2:1**

FLUID P.S.I. RANGE: **60 - 312**

650439-X4X FOUR-BALL PUMP

RELEASED: 9-25-98
REVISED: 10-5-05
REV. 03 S-936

DIMENSIONAL DATA

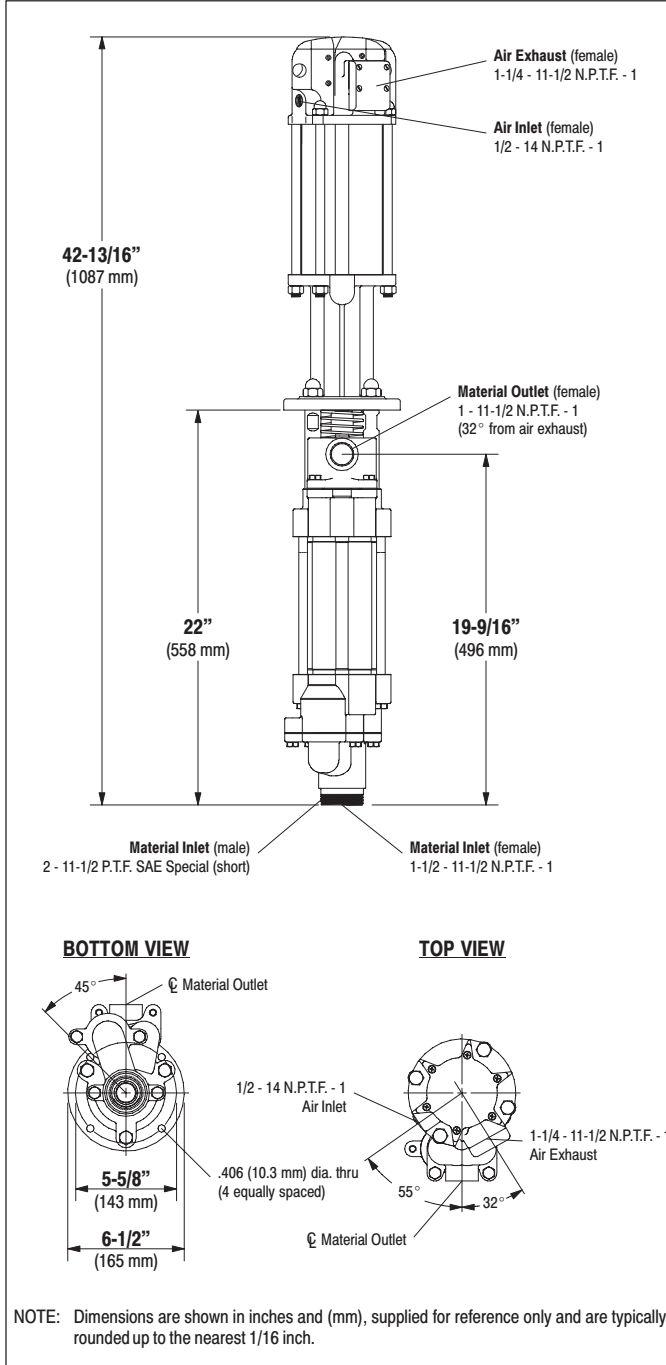

SPECIFICATIONS

CONSTRUCTION

Model Series (refer to option chart)	650439-X4X
Pump Type	Air Operated, Four-Ball
Ratio	2:1
Air Motor	65465-B
Motor Repair Kit	61268
Motor Diameter	4-1/4" (10.8 cm)
Stroke	6" (15.2 cm)
Air Inlet (female)	1/2 - 14 N.P.T.F. - 1
Air Exhaust (female)	1-1/4 - 11-1/2 N.P.T.F. - 1
Lower Pump End	67200-X4X
Lower Pump Repair Kit	637317-X4B
Packing Options:	

- 7 - Glass Filled Teflon (upper)
Virgin Teflon (lower)
- C - UHMW-PE (upper and lower)
- F - UHMW-PE / Leather staggered (upper)
UHMW-PE (lower)
- P - UHMW-PE / Glass Filled Teflon staggered (upper)
UHMW-PE (lower)
- R - Glass Filled Teflon / UHMW-PE staggered (upper)
Glass Filled Teflon (lower)

Material Inlet (female)	1-1/2 - 11-1/2 N.P.T.F. - 1
(male)	2 - 11-1/2 P.T.F. SAE (short)
Material Outlet (female)	1 - 11-1/2 N.P.T.F. - 1

MATERIALS OF CONSTRUCTION

Outlet Body	CF8M Stainless Steel
Cylinder (650439-X4B)	304 Stainless Steel ceramic coated
(650439-X43)	304 Stainless Steel hard chrome plated
Plunger (650439-X4B)	17-4 Stainless Steel ceramic coated
(650439-X43)	17-4 Stainless Steel hard chrome plated
Upper Ball	316 Stainless Steel
Upper Seat	17-4 Stainless Steel
Lower Ball	316 Stainless Steel
Lower Seat	17-4 Stainless Steel
Inlet Body	CF8M Stainless Steel
Weight	68 lbs (30.8 kgs)

PERFORMANCE

Air Inlet Pressure Range	30 - 150 p.s.i. (2.1 - 10.3 bar)
Fluid Pressure Range	60 - 312 p.s.i. (4.1 - 21.5 bar)
Maximum Rec'd Cycles / Minute	60
Displacement In³ Per Cycle	82.1
Volume / Cycle	45.5 oz. (1344 ml)
Cycles Per Gallon	2.8
Flow @ 60 Cycles / Minute	21.3 g.p.m. (80.6 l.p.m.)
Noise Level @ 60 p.s.i. - 40 c.p.m.①	81.8 db(A)

① Tested with 91790 silencer installed. The pump sound pressure level has been updated to an Equivalent Continuous Sound Level (L_{Aeq}) to meet the intent of ANSI S1.13-1971, CAGI-PNEUROP S5.1 using four microphone locations.

ACCESSORIES:

- 66101 Wall Mount Bracket
- 67187-1 Mounting Post
- 91790 Silencer

INGERSOLL-RAND COMPANY
P.O. BOX 151 • ONE ARO CENTER • BRYAN, OHIO 43506-0151

☎ (800) 276-4658 • FAX (800) 266-7016 ©2005 CCN 99738007



PERFORMANCE CURVES

