



89-500 Series

Carbon Steel Ball Valve With Spring Return Handle

Threaded, 1/4" to 1" 2000 psig WOG, 1-1/4" to 2" 1500 psig WOG.
 Cold Non-Shock, 150 psig Saturated Steam, Vacuum Service to 29 inches Hg.
 Federal Specification: WW-V-35C, Type: II, Composition: CS, Style: 3.
 MSS SP-110; Ball Valves Threaded, Socket-Welding, Solder Joint, Grooved and Flared Ends.

FEATURES

- Spring return to close (-01)
- Spring return to open (-08)
- RPTFE stuffing box ring
- All components of lever are stainless steel
- Nitride corrosion protection
- Operating torque is approximately three times standard valve torque
- Blow-out-proof stem design
- Adjustable packing gland
- Investment cast components
- Multifill seats

STANDARD MATERIAL LIST

1. Handle	SS	6. Retainer	A108-CS (1/4" to 1")
2. Stem packing	Multifill PTFE	7. Gland nut	A216-WCB (1-1/4" to 2")
3. Stem bearing	RPTFE	8. Stem	A108-CS
4. Ball	A108-CS chrome plated	9. Lever nut	A276-316
5. Seat (2)	Multifill PTFE	10. Body seal	Steel, Zinc Plated
		11. Body	PTFE (1-1/4" to 2")
			A216-WCB

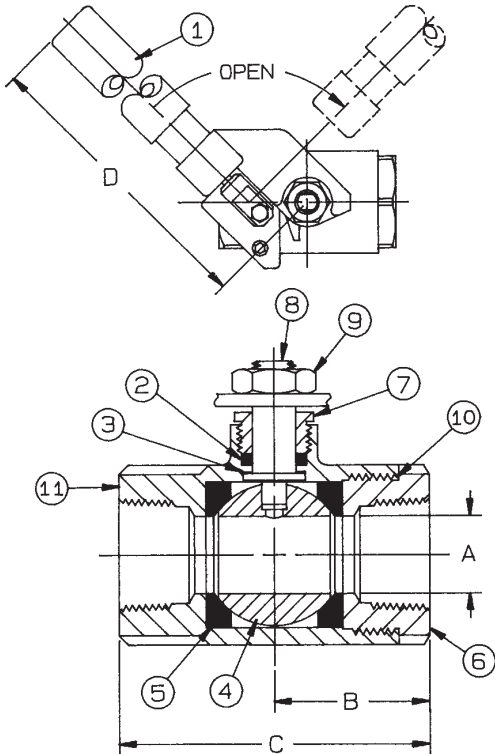

CARBON STEEL BALL VALVE WITH SPRING RETURN HANDLE

NUMBER	SIZE	A	B	C	D	Wt.
89-501-01	1/4"	.37	1.03	2.06	7.00	1.26
89-502-01	3/8"	.37	1.03	2.06	7.00	1.25
89-503-01	1/2"	.50	1.12	2.25	7.00	1.31
89-504-01	3/4"	.68	1.50	3.00	7.00	1.98
89-505-01	1"	.87	1.68	3.37	7.00	2.35
89-506-01	1-1/4"	1.00	2.00	4.00	9.00	3.96
89-507-01	1-1/2"	1.25	2.18	4.37	9.00	4.78
89-508-01	2"	1.50	2.75	5.50	9.00	6.66

VARIATIONS AVAILABLE:

89-540 Series (316 SS Ball & Stem)

OPTIONS AVAILABLE:

(SUFFIX)	OPTION	SIZES
-08-	90° Reversed Stem	1/4" to 2"
-14-	Side Vented Ball (Uni-Directional)	1/4" to 2"
-21-	UHMWPE Seats (Non-PTFE)	1/4" to 2"
-24-	Graphite Packing	1/4" to 2"
-35-	VTFE Trim	1/4" to 2"
-P01-	BSPP (Parallel) Thread Connection	1/4" to 2"
-T01-	BSPT (Tapered) Thread Connection	1/4" to 2"

**For Pressure/Temperature Ratings,
 Refer to Page M-12, Graph No. 13
 (1/4" to 1")
 Refer to Page M-11 Graph No. 11
 (1-1/4" to 2")**