



86C-200 Series

3-Piece Full Port Alloy 20

Class 600 Socket-Weld Ball Valve



Standard Compliance - Valve design: ASME B16.34, Class 600, End Connections: Socket-weld per ASME B16.11, Valve Marking: ASME B16.34, Production Testing: ASME B16.34, NACE MR0175, 2000 edition.

FEATURES

- 3-Piece construction w/ enclosed fasteners
- Full port
- Stainless steel trim & hardware
- Swing-out center section
- Pressure balanced solid ball
- Compression controlled spiral wound gaskets
- Anti-blowout one piece bottom entry stem
- Statically grounded ball, stem, & body
- Two-position locking
- Adjustable multi-piece PTFE "V" style packing
- Fully machined ISO 5211 mounting
- Cast bosses on the center-section and end caps for bleed & drain ports
- Vacuum service to 29 in of Hg.
- CE mark, 1-1/4" and larger
- 250 psig saturated steam

STANDARD MATERIAL LIST

1. Body	ASTM A351-CN7M	10. Body Nuts	ASTM A194-Gr.8
2. End Caps	ASTM A351-CN7M	11. Stop Bolts	18-8 Stainless Steel
3. Ball	ASTM B473 (UNS N08020) or ASTM-CN7M	12. Gland Bolts	ASTM A193-Gr.B8
4. Stem	ASTM B473 (UNS N08020)	13. Handle Nut/Screw	300 Series Stainless Steel
5. Seat	Multi-Seal	14. Packing Gland	ASTM A276-316SS
6. Packing	PTFE	15. Gland Plate	300 Series Stainless Steel
7. Stem Bearing	PEEK/PTFE	16. Lever Handle	300 Series Stainless Steel
8. Body Gasket	PTFE Spiral Wound	17. Lock Plate	300 Series Stainless Steel
9. Body Bolts	ASTM A193-Gr.B8M3	18. Stops	300 Series Stainless Steel
		19. Int. Grnd. Spring	300 Series Stainless Steel
		20. Ext. Grnd. Spring	300 Series Stainless Steel

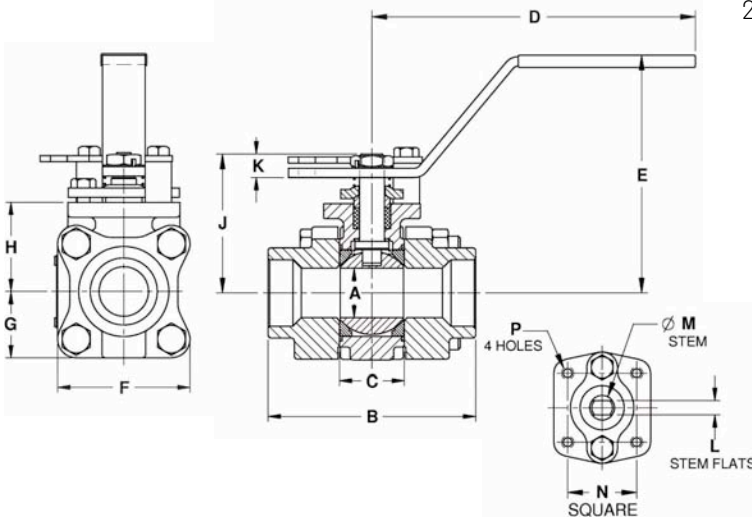

For Pressure/Temperature Ratings,
Refer to Page M-19, Graph No. 27

OPTIONS AVAILABLE:

(SUFFIX)	OPTION	SIZES
-04-	2-1/4" Stem Extension	1/4" to 2"
-14-	Vented Ball (see page J-2)	1/4" to 2"
-15-	Round Handle	1/4" to 2"
-21-	UHMWPE Seats w/Graphite Seals	1/4" to 2"
-24-	Fire Safe - Graphite Packing & Gaskets (API 607, 5th ed., ISO 10497-5)	1/4" to 2"
-38-	Peek Seats, Graphite Stem Packing & Gaskets	1/4" to 2"
-49-	Assembled Dry	1/4" to 2"
-57-	Cleaned for Oxygen Service	1/4" to 2"
-62-	Center Section Only	1/4" to 2"
-69-	Drilled & Tapped Purge & Drains	1/4" to 2"
-70-	Extended Bonnet	1/4" to 2"
-76-	Live Loaded (Lever Operated)	1/4" to 2"
-77-	Live Loaded (Actuated)	1/4" to 2"
-90-	Extended Bonnet w/Double Packing	1/4" to 2"
-SR-	Spring Return Handle	1/4" to 1"

ALLOY 20 3-PIECE FULL PORT BALL VALVE

NUMBER	SIZE	A	B	C	D	E	F	G	H	J	K	L	M	N	P	WT.
86C-201-01	1/4"	.37	2.80	0.89	5.12	3.02	2.02	1.01	1.39	1.97	0.23	0.245	0.375	1.00	10-24	2.3
86C-202-01	3/8"	.50	2.80	0.89	5.12	3.02	2.02	1.01	1.39	1.97	0.23	0.245	0.375	1.00	10-24	2.3
86C-203-01	1/2"	.50	2.80	0.89	5.12	3.02	2.02	1.01	1.39	1.97	0.23	0.245	0.375	1.00	10-24	2.3
86C-204-01	3/4"	0.75	3.68	1.10	5.53	3.40	2.40	1.20	1.65	2.35	0.24	0.312	0.500	1.392	1/4-20	4.0
86C-205-01	1"	1.00	4.19	1.31	6.53	4.80	2.67	1.34	1.80	2.80	0.48	0.287	0.500	1.392	1/4-20	5.7
86C-206-01	1-1/4"	1.50	4.50	1.97	6.65	4.70	3.84	1.92	2.49	3.89	0.72	0.412	0.625	1.949	5/16-18	14.2
86C-207-01	1-1/2"	1.50	4.98	1.97	6.65	4.70	3.84	1.92	2.49	3.89	0.72	0.412	0.625	1.949	5/16-18	14.4
86C-208-01	2"	2.00	5.86	2.56	8.40	5.47	4.92	2.46	3.17	4.74	0.80	0.477	0.750	1.949	5/16-18	27.6

FLOW DATA

For Apollo® Ball Valves

The listed Cv "factors" are derived from actual flow testing, in the Apollo® Ball Valve Division, Conbraco Industries, Inc., Pageland, South Carolina. These tests were completed using standard "off the shelf" valves with no special preparation and utilizing standard schedule 40 pipe. It should be understood that these factors are for the valve only and also include the connection configuration. The flow testing is done utilizing water as a fluid media and is a direct statement of the gallons of water flowed per minute with a 1 psig pressure differential across the valve/connection unit. Line pressure is not a factor. Because the Cv is a factor, the formula can be used to estimate flow of most media for valve sizing.

Flow of Liquid

$$Q = Cv \sqrt{\frac{\Delta P}{SpGr}}$$

$$\text{or } \Delta P = \frac{(Q)^2 (SpGr)}{(Cv)^2}$$

Where:

Q = flow in US gpm
 ΔP = pressure drop (psig)
 SpGr = specific gravity at flowing temperature
 Cv = valve constant

Flow of Gas

$$Q = 1360 Cv \sqrt{\frac{(\Delta P) (P_1)}{(SpGr) (T)}}$$

$$\text{or } \Delta P = \frac{5.4 \times 10^{-7} (SpGr) (T)}{(Q)^2} (P_2)$$

Where:

Q = flow in SCFH
 ΔP = pressure drop (psig)
 SpGr = specific gravity (based on air = 1.0)
 P₁ = outlet pressure-psia (psig + 14.7)
 T = (temp. °F + 460)
 Cv = valve constant

Cv FACTORS

SERIES:

70-100, 71-100, 71AR, 73A-100,
 74-100, 76-100, 76AR, 80-100
 81-100, 89-100

SIZE		1/4"	3/8"	1/2"	3/4"	1"	1-1/4"	1-1/2"	2"	2-1/2"	3"	4"
OPEN	90°	8.4	7.2	15	30	43	48	84	108	503	370	670

Cv FACTORS

76F, 77, 77AR, 77C, 77D SERIES

SIZE		1/4"	3/8"	1/2"	3/4"	1"	1-1/4"	1-1/2"	2"	2-1/2"
OPEN	90°	8.1	15	15	51	68	125	177	389	503

Cv FACTORS

82-100/200, 83R-100/200/700, 85R-100/200, 86R-100/200/700, 83-500/600, 86-500/600/900 SERIES

SIZE		1/4"	3/8"	1/2"	3/4"	1"	1-1/4"	1-1/2"	2"	2-1/2"	3"	4"
OPEN	90°	8.1	14	26	51	68	120	170	376	510	996	1893

Cv FACTORS

83A/83B, 86A/86B, 86C SERIES

SIZE		1/4"	3/8"	1/2"	3/4"	1"	1-1/4"	1-1/2"	2"
OPEN	90°	8.1	14	26	51	68	120	170	376

ASME Class 600 Alloy 20 P-T Rating (Graph 27)

