

ABS submersible sewage pump AFP 0831-2046

Robust, reliable submersible pumps from 1.3 to 30 kW for pumping wastewater and sewage from buildings and sites in private, commercial, industrial and municipal areas in accordance with EN 12050-1. Available as standard AFP or as higher specification AFP(K).



Applications

AFP submersible pumps have been designed for the economic and reliable pumping of clear or wastewater, gaseous liquids, and for sewage and sludge, in fixed or portable applications.

- For fixed, wet well applications the AFP is pedestal mounted. Using a self-sealing coupling system the pump seals automatically on the pedestal when lowered by guide rail into position.
- Dry well applications have the option of horizontal or vertical installation.
- With vortex hydraulics the AFP is particularly suitable for sewage, abrasive matter, and fluids containing stringy materials that tend to "rope".
- The Contrablock hydraulic system offers higher efficiency and is suitable for larger proportions of solid or fibrous matter.

Construction

The water-pressure-tight, encapsulated, fully flood-proof motor and the pump section form a compact, robust, modular construction. Maximum allowable temperature of the medium for continuous operation is 40 °C (information on applications at other temperatures available on request).

Available in explosion-proof versions in accordance with international standards EExd II BT4, FM and ATEX.

Cooling

AFP: Free-circulation cooling by the medium.

AFP(K): Closed loop cooling system with circulation of glycol and water which has no contact with the sewage being pumped. This optimises heat exchange and avoids the danger of blockage of the cooling system with sewage particles.

Dry installation is possible without cooling system, for intermittent use only and subject to strict limitations.

Bearings

The stainless steel motor shaft is supported in lubricated-for-life ball bearings.

Shaft sealing

Between the motor and hydraulic section is by means of a high quality, silicon carbide, double mechanical seal. Standard AFP has a single mechanical seal and upper lip seal. AFP(K) has the option of double mechanical seals or a seal cartridge. The seal cartridge combines both mechanical seals into a complete, easy-to-replace unit. All seals are independent of rotation direction and resistant to temperature shock.

Discharge

DN 80, 100, 150 and 200 DIN flange.

Temperature monitoring

TCS (Thermo-Control-System) with thermal sensors in the stator to switch off the pump in the case of overheating and switch on automatically after cooling down.

Seal monitoring

DI system consisting of a sensor in the motor and oil chambers which signals an inspection alert if there is leakage at the shaft seals (not in oil chamber on Ex version).

Hydraulics

AFP 0831-0835, 1031-1035, 1533: Vortex, open, recessed, four-vane impeller.

AFP 0841-0844, 1041-1049, 1541, 1543 & 2045: Contrablock, open single-vane impeller.

AFP 1546 & 2046: Contrablock, open double-vane impeller.



Features

- High-efficiency hydraulic design using Contrablock or vortex impellers.
- Available as standard AFP or higher specification AFP(K).
- AFP(K) has class H insulation and double mechanical seals as standard, with options of seal cartridge and closed loop cooling system.
- Automatic seal and temperature monitoring.
- Available as explosion-proof.
- Designed for fixed or transportable installation.
- For lifting, AFP has cast eyelet, AFP(K) has stainless steel lifting hoop.

Motor

Three-phase, 400 V, 50 Hz, squirrel-cage motor as 2-pole (2900 r/min), 4-pole (1450) and 6-pole (980).

Protection type IP 68, with stator insulation Class F (155 °C) for standard AFP or Class H (180 °C) for AFP(K) version.

Direct starting up to 3 kW; from 4 kW star-delta or direct starting is possible. Motors with other operating voltages and frequencies are also available.

Identification Code: e.g. AFP 1035.3 ME 250/2

Hydraulics:

AFP Product range

10 Discharge outlet DN (cm)

35 Hydraulic number

.3 Impeller

Motor:

ME M = modular motor; E = high efficiency

250 Motor power P_2 kW x 10

2 Number of poles

Materials

| Description | Material |
|---------------|-----------------------------------|
| Motor housing | Cast iron EN-GJL-250 |
| Motor shaft | Stainless steel 1.4021 (AISI 420) |
| Volute | Cast iron EN-GJL-250 |
| Impeller | Cast iron EN-GJL-250 |
| Bottom plate | Cast iron EN-GJL-250 |
| Fasteners | Stainless steel 1.4401 (AISI 316) |

AFP(K) options: stainless steel motor shaft 1.4401 (AISI 316), stainless steel impeller 1.4460 (AISI 329), viton seals, and surface hardened cast iron impeller and bottomplate.

AFP is available in SX version as a complete stainless steel pump (see separate literature).

Technical Data

| AFP | Impeller size | Solid size (mm) | Rated voltage (V) | Motor power * (kW) | | Rated current (A) | Speed (r/min) | Starting | Cable type ** | Weight*** (kg) | |
|------|---------------|------------------|-------------------|--------------------|----------------|-------------------|---------------|----------|---------------|----------------|---------|
| | | | | P ₁ | P ₂ | | | | | | |
| 0831 | M 15/4 | 3, 4, 5, 6, 7 | 80 | 400 3~ | 2.51 | 1.95 | 4.65 | 1450 | DOL | (a) | 78/90 |
| | M 22/4 | 2 | 80 | 400 3~ | 2.88 | 2.20 | 5.15 | 1450 | DOL | (a) | 79/90 |
| | M 30/4 | 1 | 80 | 400 3~ | 3.95 | 3.00 | 7.00 | 1450 | DOL | (a) | 80/92 |
| | S 22/4 | 2, 3 | 80 | 400 3~ | 2.88 | 2.20 | 5.15 | 1450 | DOL | (e) | 45/n.a. |
| 0832 | M 70/2 | 1, 2, 3 | 80 | 400 3~ | 8.37 | 7.00 | 13.60 | 2900 | YΔ | (b) | 105/121 |
| | M 40/2 | 4 | 80 | 400 3~ | 4.86 | 4.00 | 7.93 | 2900 | YΔ | (b) | 81/93 |
| 0834 | M 110/2 | 1, 2, 3, 4 | 80 | 400 3~ | 13.30 | 11.00 | 22.10 | 2900 | YΔ | (b) | 95/103 |
| 0835 | M 55/2 | 6 | 65 | 400 3~ | 6.49 | 5.50 | 10.40 | 2900 | YΔ | (b) | 117/130 |
| | M 70/2 | 5 | 65 | 400 3~ | 8.37 | 7.00 | 13.60 | 2900 | YΔ | (b) | 117/130 |
| | M 110/2 | 1, 2, 3, 4 | 65 | 400 3~ | 13.30 | 11.00 | 22.10 | 2900 | YΔ | (b) | 129/142 |
| 0841 | M 15/4 | 1, 2, 3, 4 | 80 | 400 3~ | 2.51 | 1.95 | 4.65 | 1450 | DOL | (a) | 78/90 |
| | M 30/4 | A | 80 | 400 3~ | 3.95 | 3.00 | 7.00 | 1450 | DOL | (a) | 80/92 |
| | S 22/4 | 1 | 80 | 400 3~ | 2.88 | 2.20 | 5.15 | 1450 | DOL | (e) | 56/n.a. |
| | S 13/4 | 2, 3, 4 | 80 | 400 3~ | 1.93 | 1.30 | 3.60 | 1450 | DOL | (e) | 41/n.a. |
| 0842 | M 40/2 | 1 | 50 | 400 3~ | 4.86 | 4.00 | 7.93 | 2900 | YΔ | (b) | 81/93 |
| 0844 | M 110/2 | 1 | 45 | 400 3~ | 13.30 | 11.00 | 22.10 | 2900 | YΔ | (b) | 110/120 |
| | M 70/2 | 2 | 45 | 400 3~ | 8.37 | 7.00 | 13.60 | 2900 | YΔ | (b) | 100/110 |
| 1031 | M 30/4 | 1 | 100 | 400 3~ | 3.95 | 3.00 | 7.00 | 1450 | DOL | (a) | 80/92 |
| | M 22/4 | 2 | 100 | 400 3~ | 2.88 | 2.20 | 5.15 | 1450 | DOL | (a) | 78/90 |
| | M 15/4 | 3, 5, 6, 7 | 100 | 400 3~ | 2.51 | 1.95 | 4.65 | 1450 | DOL | (a) | 78/90 |
| 1032 | M 90/4 | A | 100 | 400 3~ | 10.80 | 9.00 | 19.40 | 1450 | YΔ | (b) | 120/136 |
| | M 60/4 | 1 | 100 | 400 3~ | 7.22 | 6.00 | 12.50 | 1450 | YΔ | (b) | 110/126 |
| | M 40/4 | 2, 3, 4 | 100 | 400 3~ | 5.00 | 4.00 | 8.87 | 1450 | YΔ | (b) | 107/123 |
| 1033 | ME 185/4 | 1 | 100 | 400 3~ | 21.30 | 18.50 | 36.50 | 1450 | YΔ | (c) | 290/320 |
| | ME 160/4 | 2, 3 | 100 | 400 3~ | 18.20 | 16.00 | 32.00 | 1450 | YΔ | (c) | 285/315 |
| | ME 110/4 | 4 | 100 | 400 3~ | 12.70 | 11.00 | 22.10 | 1450 | YΔ | (b) | 280/310 |
| 1034 | ME 250/2 | 1, 2, 3, 4, 5, 6 | 75 | 400 3~ | 28.40 | 25.00 | 44.60 | 2900 | YΔ | (d) | 240/270 |
| | ME 200/2 | 1, 2, 3, 4, 5, 6 | 75 | 400 3~ | 22.30 | 20.00 | 35.00 | 2900 | YΔ | (c) | 230/260 |
| | ME 185/2 | 7 | 75 | 400 3~ | 20.40 | 18.50 | 32.30 | 2900 | YΔ | (c) | 225/255 |
| | ME 150/2 | 8 | 75 | 400 3~ | 16.70 | 15.00 | 27.10 | 2900 | YΔ | (c) | 220/250 |
| 1035 | ME 150/2 | 6, 7 | 64 | 400 3~ | 16.70 | 15.00 | 27.10 | 2900 | YΔ | (c) | 222/250 |
| | ME 200/2 | 5 | 64 | 400 3~ | 22.30 | 20.00 | 35.00 | 2900 | YΔ | (c) | 227/255 |
| | ME 250/2 | 1, 2, 3, 4 | 64 | 400 3~ | 28.40 | 25.00 | 44.60 | 2900 | YΔ | (d) | 232/260 |
| 1041 | M 30/4 | 1,2 | 90 | 400 3~ | 3.95 | 3.00 | 7.00 | 1450 | DOL | (a) | 80/92 |
| | M 22/4 | 3 | 90 | 400 3~ | 2.88 | 2.20 | 5.15 | 1450 | DOL | (a) | 78/90 |
| | M 15/4 | 4 | 90 | 400 3~ | 2.51 | 1.95 | 4.65 | 1450 | DOL | (a) | 78/90 |
| 1042 | M 90/4 | A | 100 | 400 3~ | 10.80 | 9.00 | 19.40 | 1450 | YΔ | (b) | 117/133 |
| | M 60/4 | 1, 2 | 100 | 400 3~ | 7.22 | 6.00 | 12.50 | 1450 | YΔ | (b) | 110/126 |
| | M 40/4 | 3 | 100 | 400 3~ | 5.00 | 4.00 | 8.87 | 1450 | YΔ | (b) | 107/123 |
| 1043 | M 70/2 | 1 | 55 | 400 3~ | 8.37 | 7.00 | 13.60 | 2900 | YΔ | (b) | 105/121 |
| 1045 | ME 220/4 | A | 100 | 400 3~ | 24.70 | 22.00 | 43.10 | 1450 | YΔ | (d) | 300/320 |
| | ME 185/4 | 1 | 100 | 400 3~ | 21.30 | 18.50 | 36.50 | 1450 | YΔ | (c) | 290/320 |
| | ME 160/4 | 2, 2B | 100 | 400 3~ | 18.20 | 16.00 | 32.00 | 1450 | YΔ | (c) | 285/315 |
| | ME 140/4 | 2B | 100 | 400 3~ | 16.40 | 14.00 | 28.80 | 1450 | YΔ | (b) | 285/315 |
| | ME 110/4 | 3 | 100 | 400 3~ | 12.70 | 11.00 | 22.10 | 1450 | YΔ | (b) | 280/310 |
| 1048 | ME 250/2 | 1 | 50 | 400 3~ | 28.40 | 25.00 | 44.60 | 2900 | YΔ | (d) | 250/275 |
| | ME 185/2 | 2 | 50 | 400 3~ | 20.40 | 18.50 | 32.30 | 2900 | YΔ | (c) | 245/270 |
| | ME 150/2 | 3 | 50 | 400 3~ | 16.70 | 15.00 | 27.10 | 2900 | YΔ | (c) | 240/265 |
| 1049 | M 90/4 | A, 2 | 80 | 400 3~ | 10.80 | 9.00 | 19.40 | 1450 | YΔ | (b) | 129/145 |
| | M 60/4 | 3 | 80 | 400 3~ | 7.22 | 6.00 | 12.50 | 1450 | YΔ | (b) | 119/135 |
| | M 40/4 | 4 | 80 | 400 3~ | 5.00 | 4.00 | 8.87 | 1450 | YΔ | (b) | 111/127 |
| 1533 | ME 185/4 | 1 | 100 | 400 3~ | 21.30 | 18.50 | 36.50 | 1450 | YΔ | (c) | 295/325 |
| | ME 160/4 | 2 | 100 | 400 3~ | 18.20 | 16.00 | 32.00 | 1450 | YΔ | (c) | 290/320 |
| | ME 140/4 | 3 | 100 | 400 3~ | 16.40 | 14.00 | 28.80 | 1450 | YΔ | (b) | 285/315 |
| | ME 110/4 | 4 | 100 | 400 3~ | 12.70 | 11.00 | 22.10 | 1450 | YΔ | (b) | 285/315 |
| 1541 | M 90/4 | A | 100 | 400 3~ | 10.80 | 9.00 | 19.40 | 1450 | YΔ | (b) | 122/133 |
| | M 60/4 | 1, 2 | 100 | 400 3~ | 7.22 | 6.00 | 12.50 | 1450 | YΔ | (b) | 110/126 |
| | M 40/4 | 3, 4, 5 | 100 | 400 3~ | 5.00 | 4.00 | 8.87 | 1450 | YΔ | (b) | 107/123 |
| 1543 | ME 220/4 | A | 100 | 400 3~ | 24.70 | 22.00 | 43.10 | 1450 | YΔ | (d) | 300/330 |
| | ME 185/4 | 1 | 100 | 400 3~ | 21.30 | 18.50 | 36.50 | 1450 | YΔ | (c) | 295/325 |
| | ME 160/4 | 2 | 100 | 400 3~ | 18.20 | 16.00 | 32.00 | 1450 | YΔ | (c) | 290/320 |
| | ME 140/4 | 2B | 100 | 400 3~ | 16.40 | 14.00 | 28.80 | 1450 | YΔ | (b) | 290/320 |
| | ME 110/4 | 3 | 100 | 400 3~ | 12.70 | 11.00 | 22.10 | 1450 | YΔ | (b) | 285/315 |

Electrical and cable data is for 400 V version only; data for alternative voltages available on request.

 * P₁ = power at mains; P₂ = power at motor shaft

** Neoprene cable: (a) 7G1.5 (b) 10G1.5 (c) 10G2.5 (d) 4G4 + 2x0.75 (e) 4G1.5 [4G1.5 + 3x0.75 for version with Klixon]

*** without/with cooling jacket

Technical Data

| AFP | Impeller size | Solid size (mm) | Rated voltage (V) | Motor power * (kW) | | Rated current (A) | Speed (r/min) | Starting | Cable type** | Weight*** (kg) | |
|-------------|---------------|-----------------|-------------------|--------------------|----------------|-------------------|---------------|----------|--------------|----------------|---------|
| | | | | P ₁ | P ₂ | | | | | | |
| 1546 | M 90/4 | A | 75 | 400 3~ | 10.80 | 9.00 | 19.40 | 1450 | YΔ | (b) | 122/133 |
| | M 60/4 | 2 | 75 | 400 3~ | 7.22 | 6.00 | 12.50 | 1450 | YΔ | (b) | 110/126 |
| | M 40/4 | 4 | 75 | 400 3~ | 5.00 | 4.00 | 8.87 | 1450 | YΔ | (b) | 107/123 |
| 2045 | ME 220/4 | 1 | 125x100 | 400 3~ | 24.70 | 22.00 | 43.10 | 1450 | YΔ | (d) | 330/360 |
| | ME 185/4 | 1 | 125x100 | 400 3~ | 21.30 | 18.50 | 36.50 | 1450 | YΔ | (c) | 330/360 |
| | ME 160/4 | 2 | 125x100 | 400 3~ | 18.20 | 16.00 | 32.00 | 1450 | YΔ | (c) | 325/355 |
| | ME 140/4 | 3 | 125x100 | 400 3~ | 16.40 | 14.00 | 28.80 | 1450 | YΔ | (b) | 290/320 |
| | ME 110/4 | 4 | 125x100 | 400 3~ | 12.70 | 11.00 | 22.10 | 1450 | YΔ | (b) | 320/350 |
| 2046 | ME 140/6 | 1 | 125x100 | 400 3~ | 16.10 | 14.00 | 28.80 | 980 | YΔ | (c) | 330/360 |
| | ME 110/6 | 2 | 125x100 | 400 3~ | 12.60 | 11.00 | 24.00 | 980 | YΔ | (b) | 325/355 |
| | ME 90/6 | 4, 5 | 125x100 | 400 3~ | 10.40 | 9.00 | 21.40 | 980 | YΔ | (b) | 325/355 |

Electrical and cable data is for 400 V version only; data for alternative voltages available on request.

* P₁ = power at mains; P₂ = power at motor shaft

** Neoprene cable: (a) 7G1.5 (b) 10G1.5 (c) 10G2.5 (d) 4G4 + 2x0.75 (e) 4G1.5 (4G1.5 + 3x0.75 for version with klixon)

*** without/with cooling jacket

Contrablock

The Contrablock impeller design ensures clog-free pumping combined with high-efficiency hydraulic performance. It can handle solid sizes up to 125 x 100 mm, including fibres and fabric which can block conventional pumping systems.

1. Shearing ring on the upper shroud of the impeller to protect the mechanical seal.
2. Open, single- or double-vane impeller with sloped deflector edge at the impeller blade.
3. Large suction inlet.
4. Bottom plate with continuous spiral groove which assists in transporting stringy material from the inlet to the discharge.
5. Gap between bottom plate and impeller is easily adjusted to restore efficiency in the event of wear.

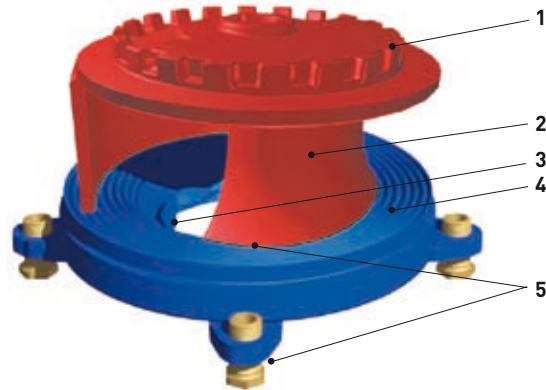

AFP(K) ME3 cross-section

1. Stainless steel lifting hoop.
2. Motor shaft ball bearings with permanent maintenance-free lubrication.
3. Motor with thermal sensors in each phase.
4. Stainless steel motor shaft.
5. Closed-loop cooling system with internal recirculation impeller.
6. Seal-minder sensor for detection of moisture in oil and motor chambers.
7. Seal cartridge unit with double mechanical seals.
8. Contrablock or vortex (featured) impeller.

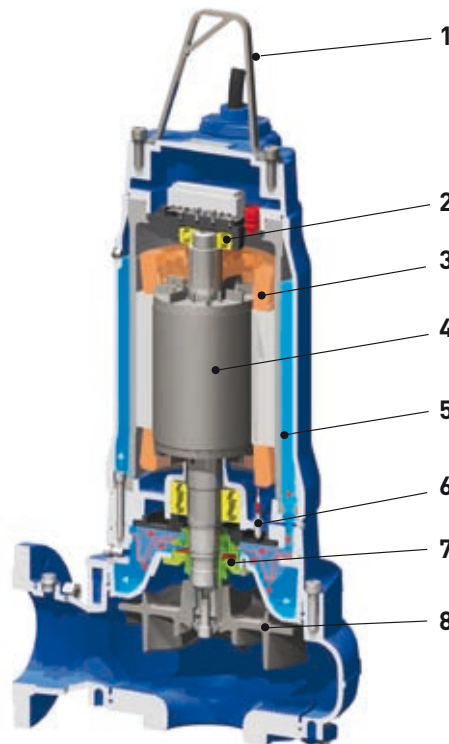

Performance Curves

AFP 0831

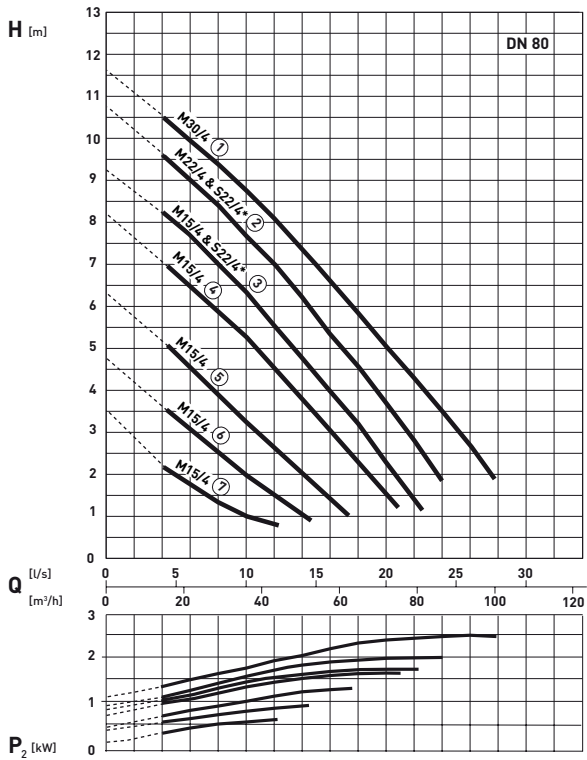

* Use only M-motor when fitted with cooling jacket

AFP 0832

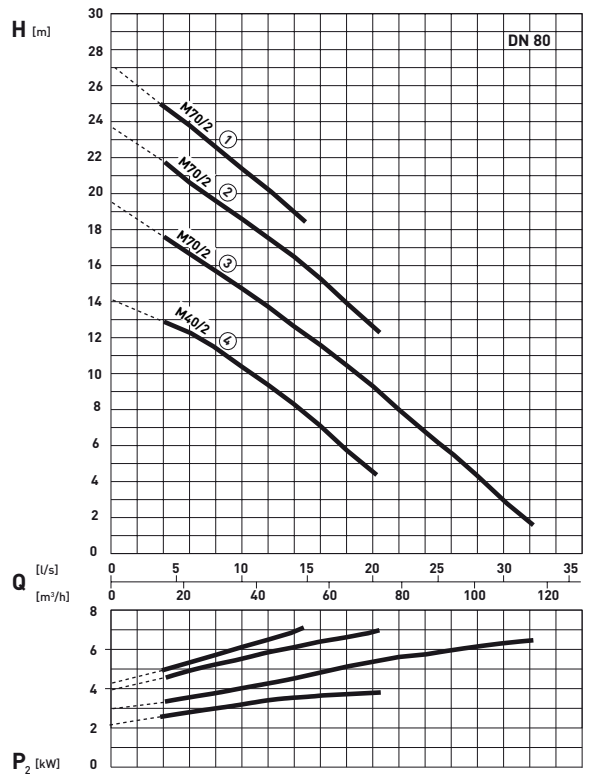

AFP 0834

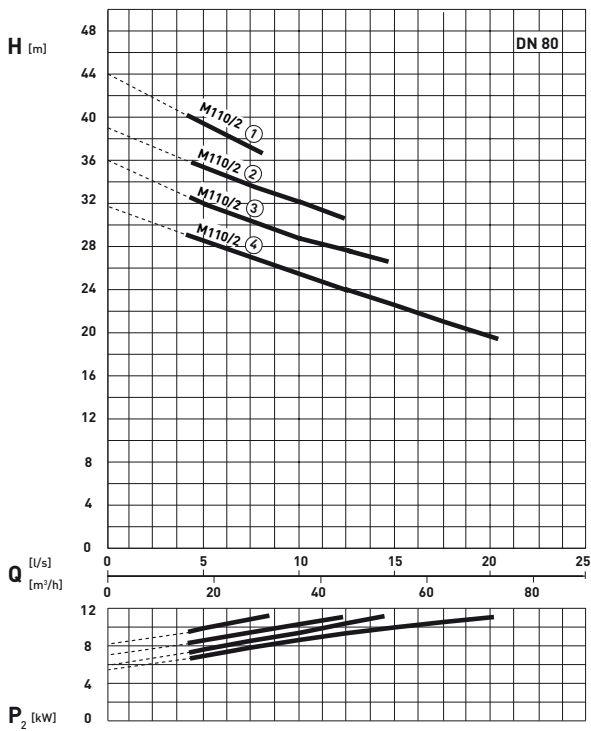

AFP 0835

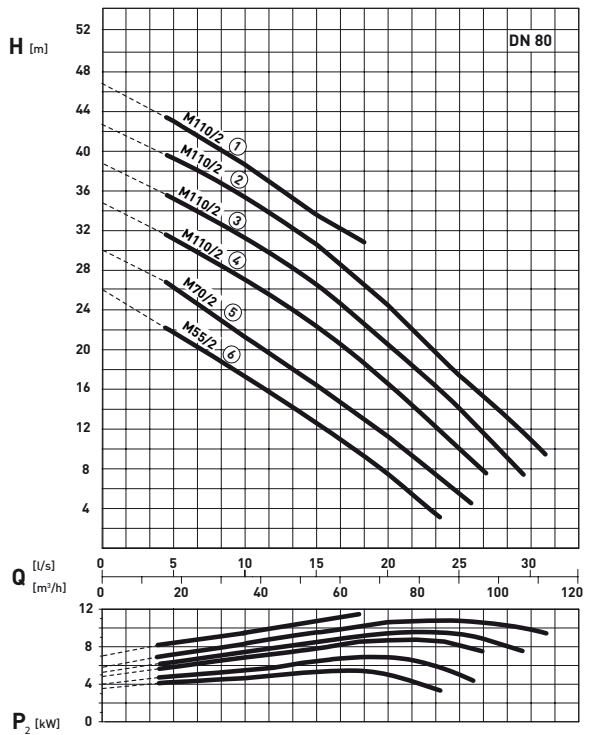

H = Total Head Q = Discharge Volume P₂ = Power at motor shaft

Curves to ISO 9906

N.B. Please use the ABSEL program to validate pump selection.

AFP 0841

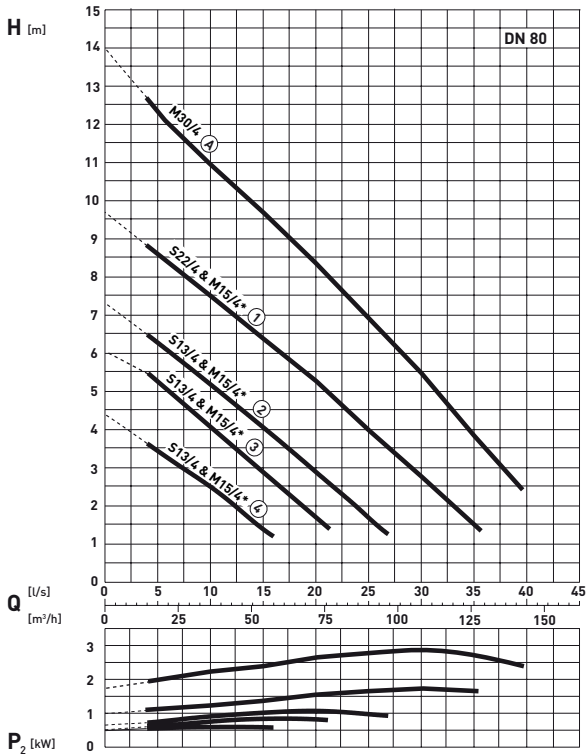

* Use only M-motor when fitted with cooling jacket

AFP 0842

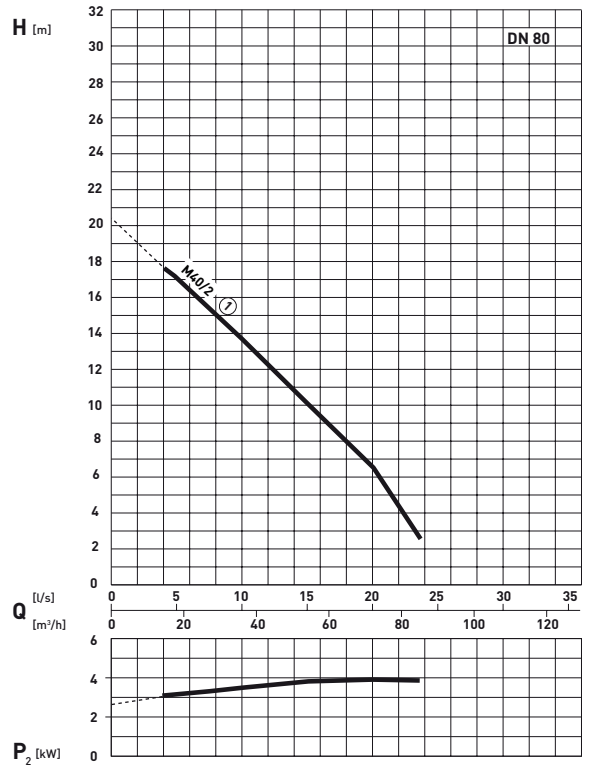

AFP 0844

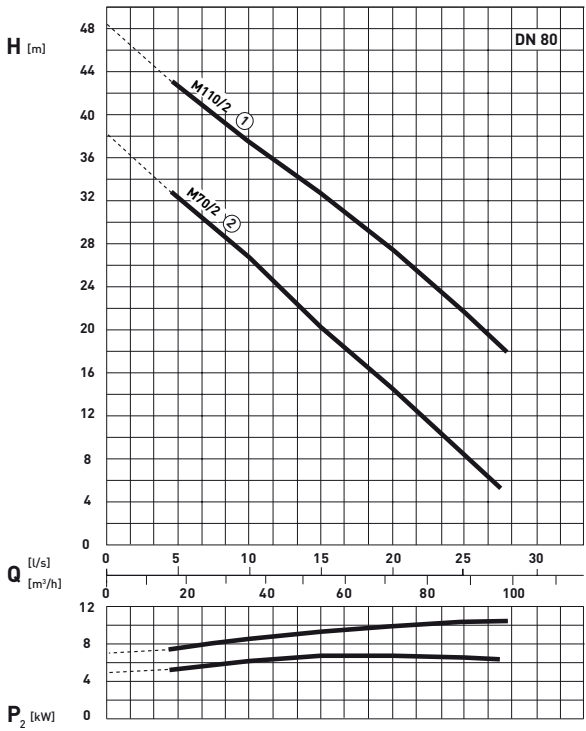

AFP 1031

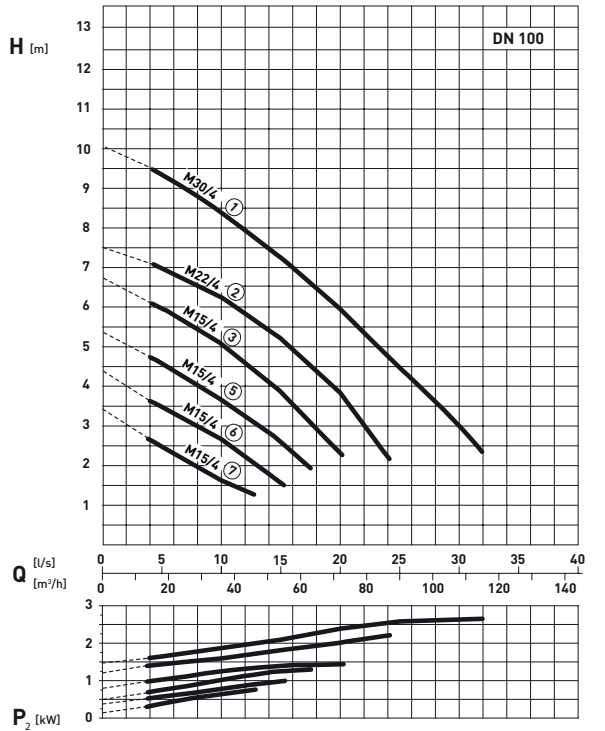

Performance Curves

AFP 1032

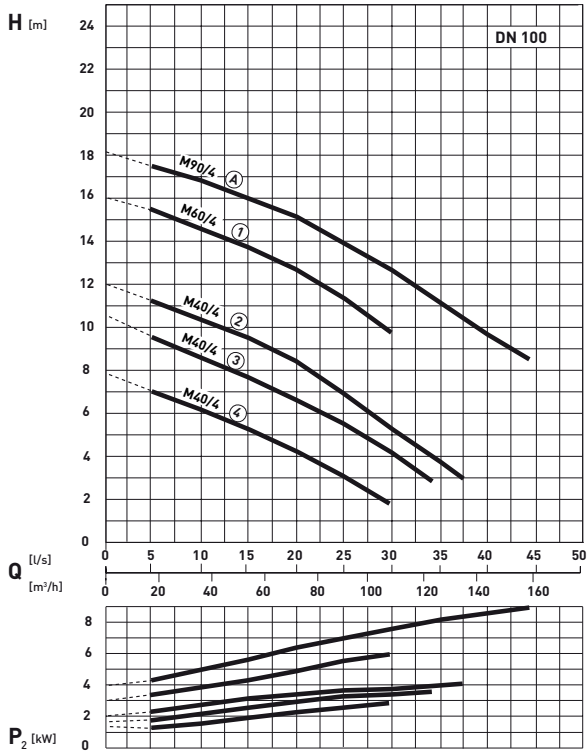

AFP 1033

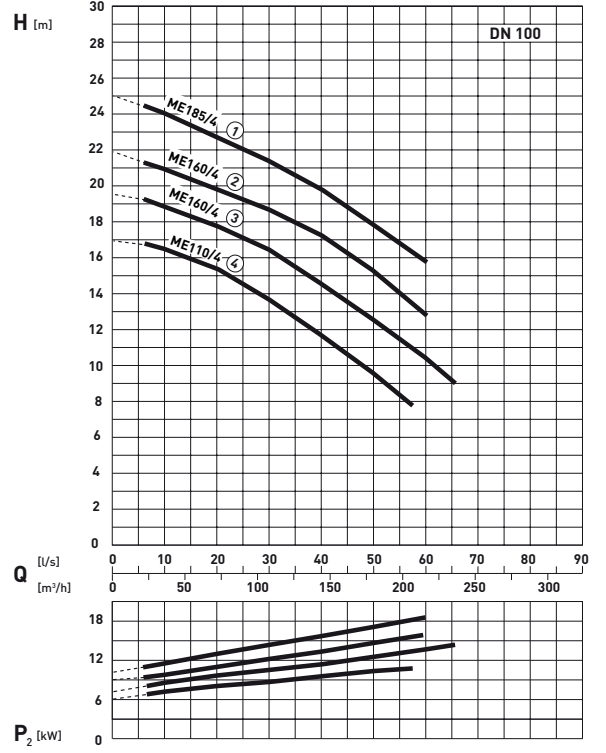

AFP 1034

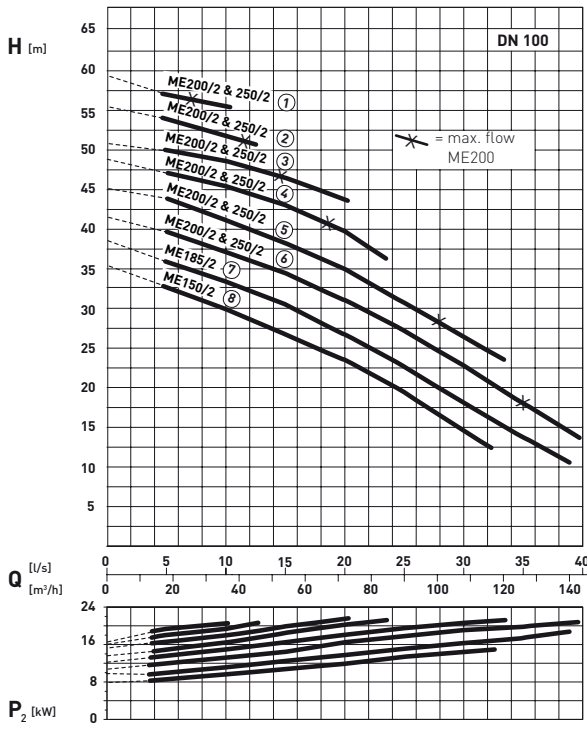

AFP 1035

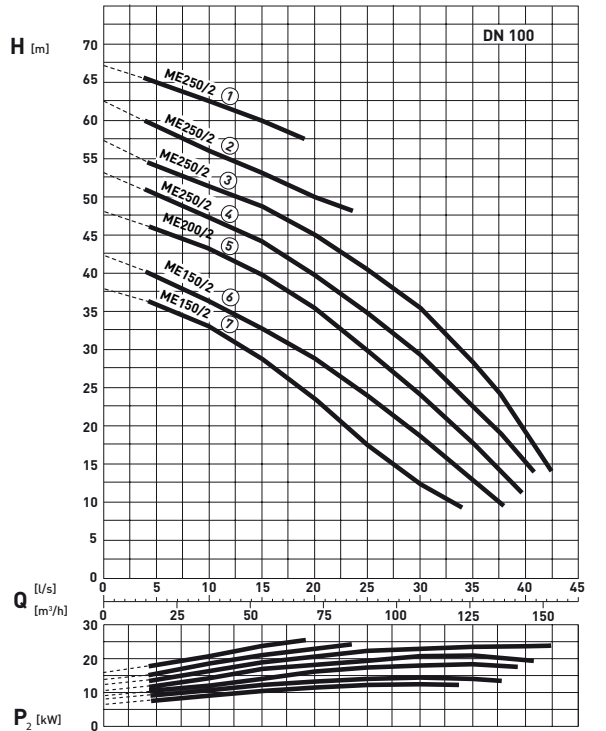

H = Total Head Q = Discharge Volume P₂ = Power at motor shaft Curves to ISO 9906 N.B. Please use the ABSEL program to validate pump selection.

AFP 1041

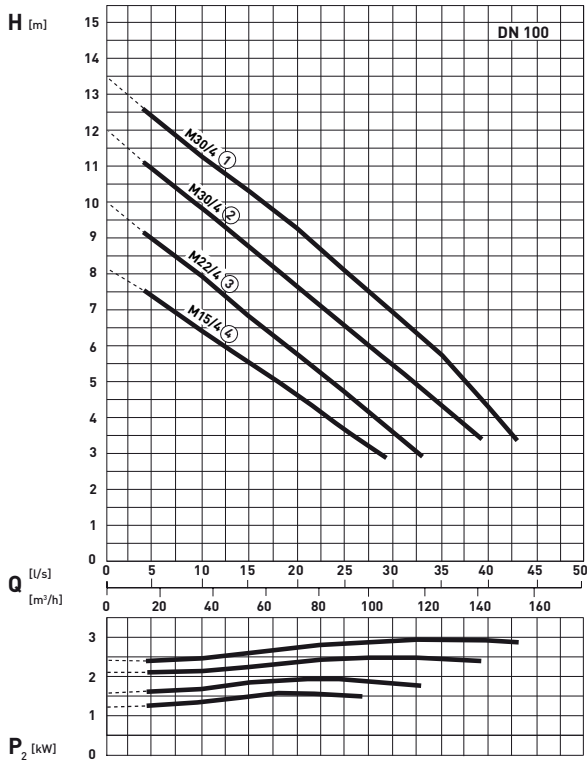

AFP 1042

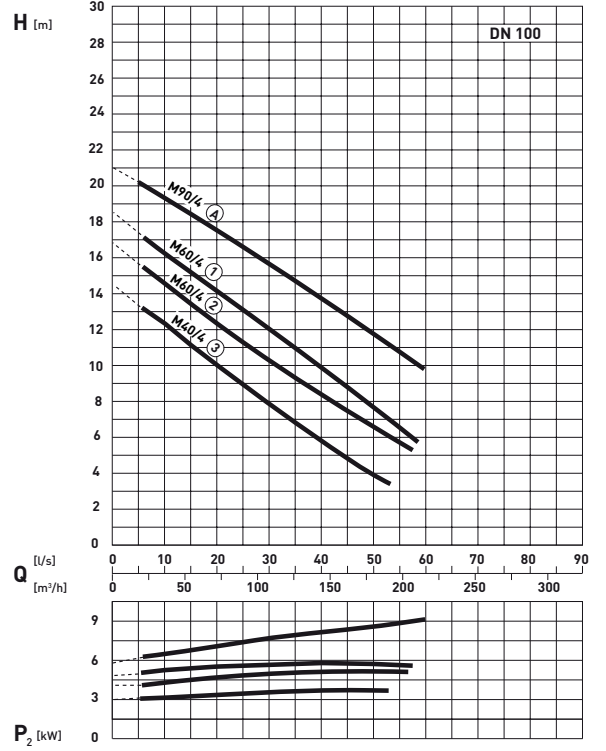

AFP 1043

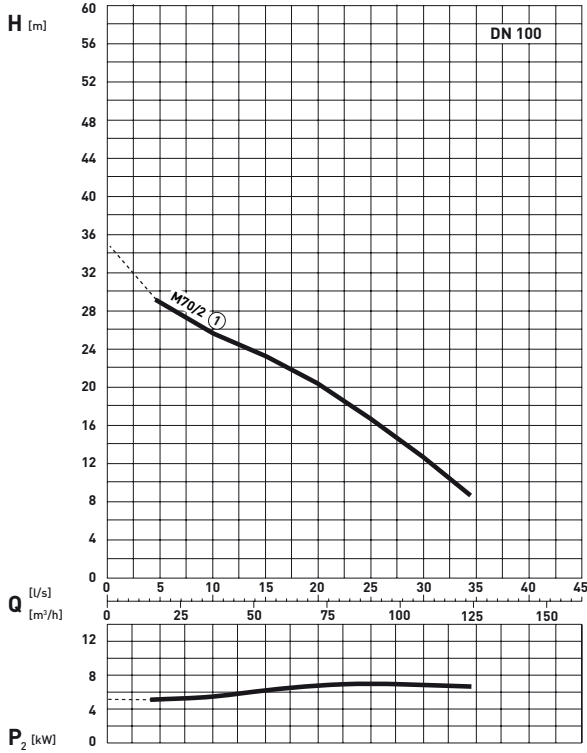

AFP 1045

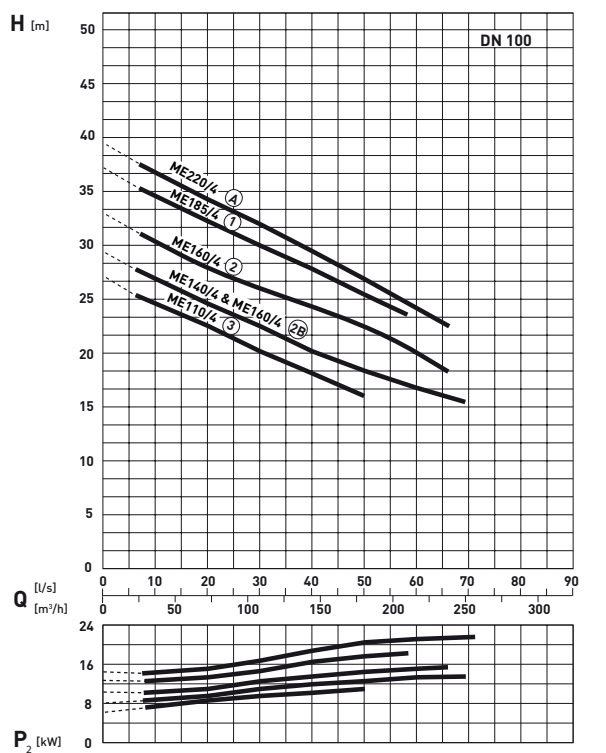

Performance Curves

AFP 1048

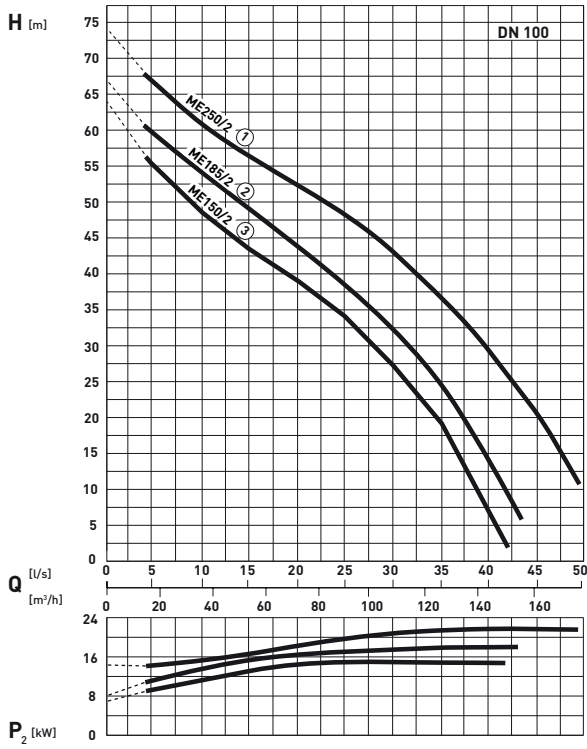

AFP 1049

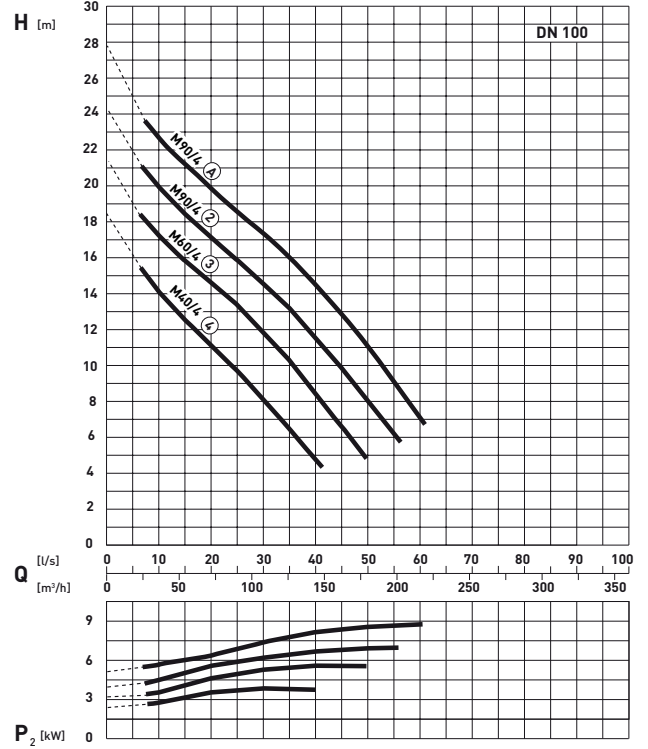

AFP 1533

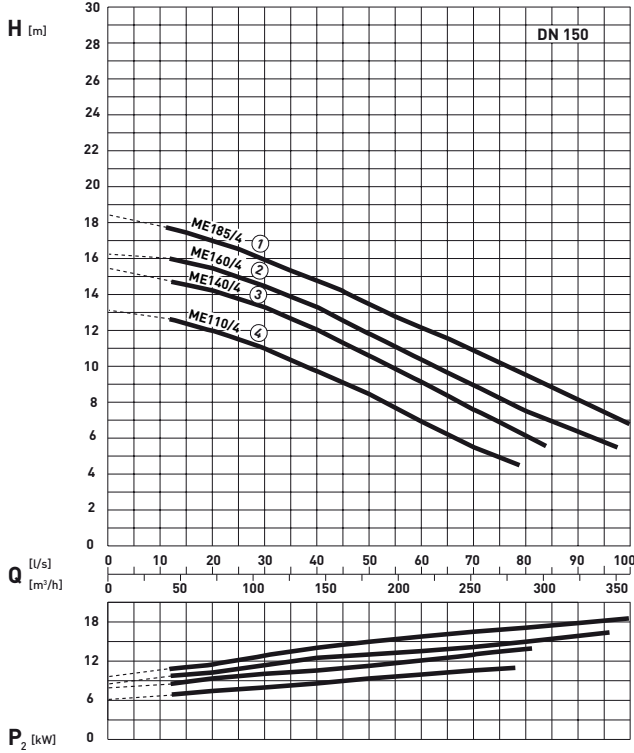

AFP 1541

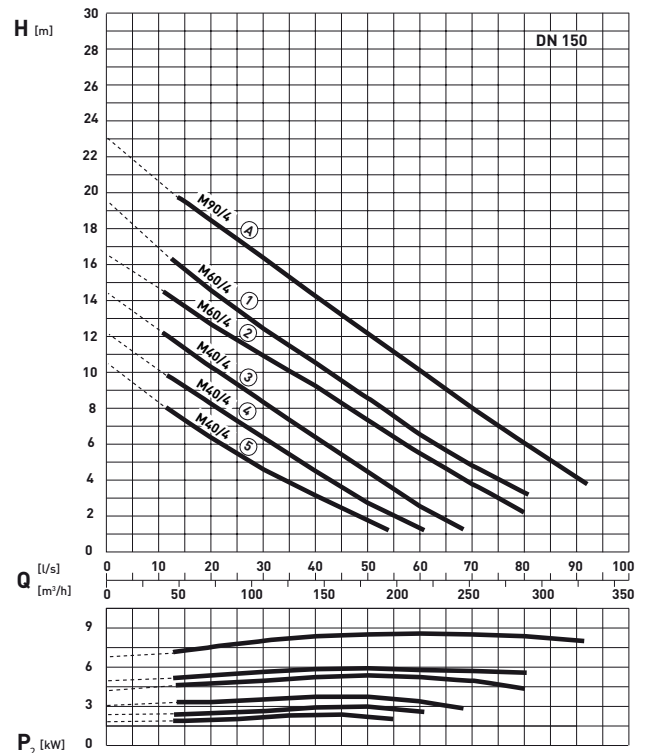

H = Total Head Q = Discharge Volume P₂ = Power at motor shaft Curves to ISO 9906 N.B. Please use the ABSEL program to validate pump selection.

AFP 1543

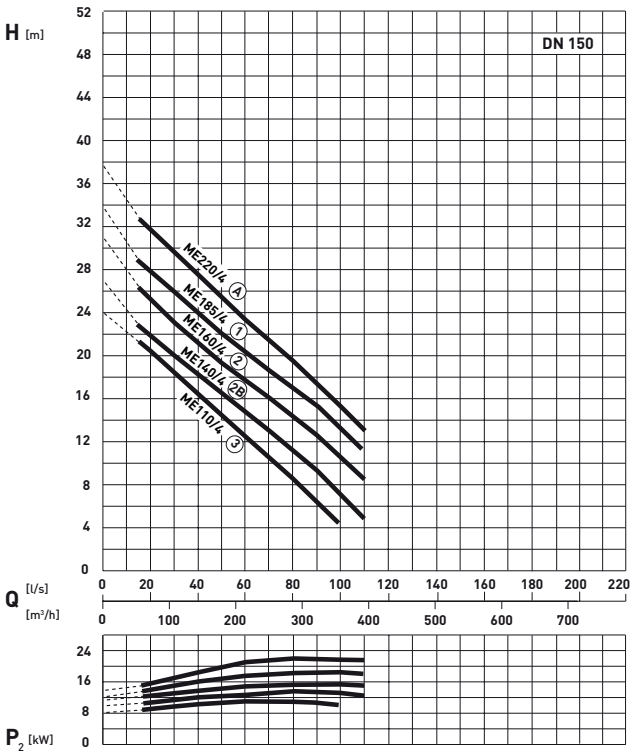

AFP 1546

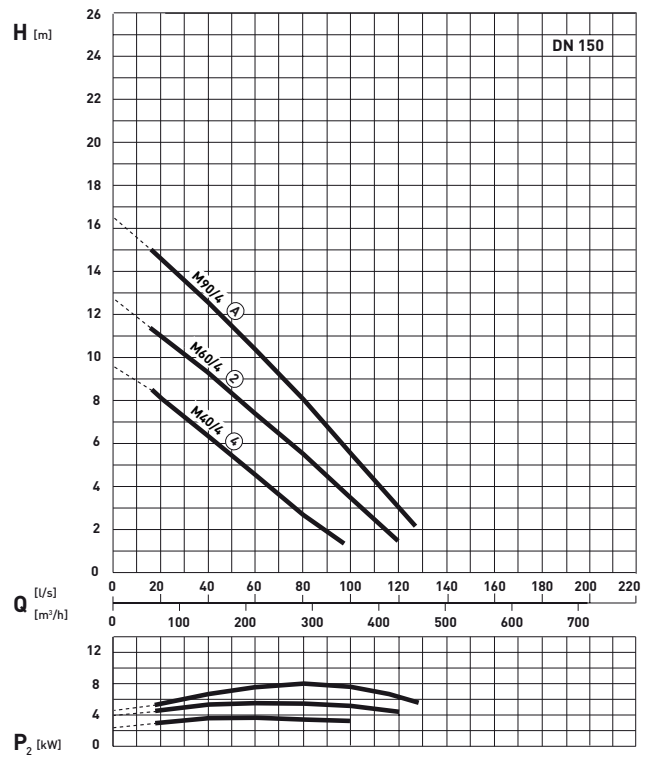

AFP 2045

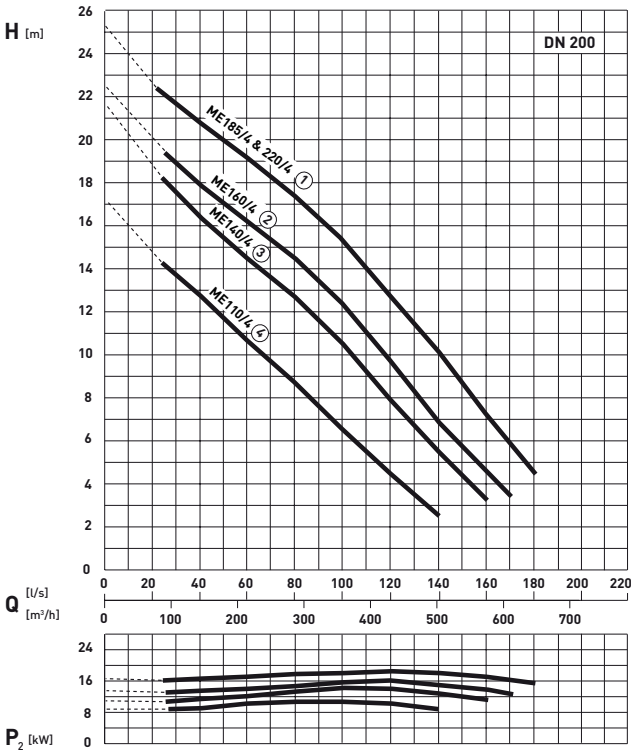

AFP 2046

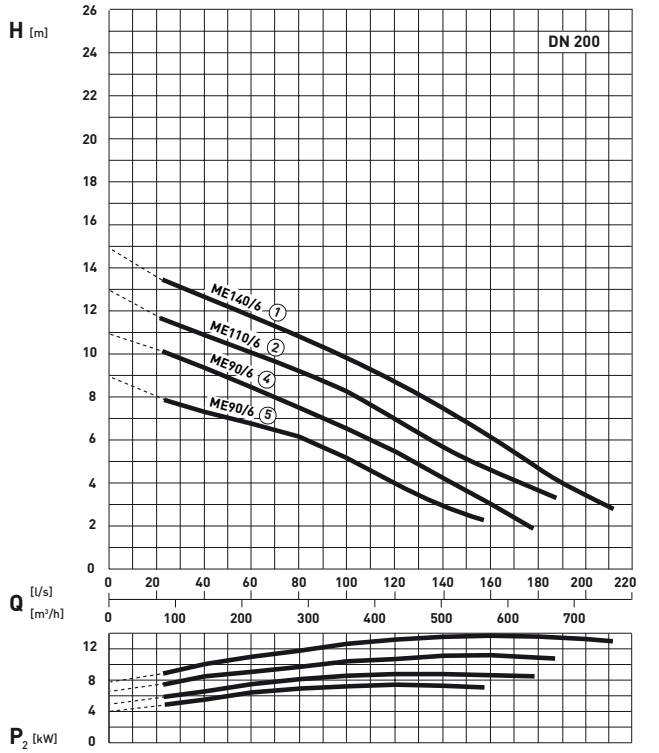

Dimensions (mm)

| AFP | DN1 | DN2 | A | B | C | D | E | F | G | G1 | G2 | G3 | H | J | K | L | M | N |
|--------------------|-----|-----|-----|-----|-----|-----|-----|------|-----|-----|-----|-----|-----|-----|-----|-----|-----|-----|
| 0831 | 80 | 80 | 167 | 88 | 340 | 200 | 250 | 651 | 275 | 700 | 256 | 350 | 100 | 161 | 162 | 625 | 210 | 130 |
| 0832 M70/2 | 80 | 80 | 167 | 88 | 340 | 200 | 250 | 696 | 275 | 700 | 256 | 350 | 100 | 161 | 162 | 625 | 210 | 130 |
| 0832 M40/2 | 80 | 80 | 167 | 88 | 340 | 200 | 250 | 651 | 275 | 700 | 256 | 350 | 100 | 161 | 162 | 625 | 210 | 130 |
| 0834 | 80 | 80 | 167 | 88 | 340 | 200 | 250 | 746 | 275 | 700 | 256 | 350 | 100 | 161 | 162 | 625 | 210 | 130 |
| 0835 | 80 | 80 | 167 | 88 | 340 | 200 | 265 | 665 | 280 | 823 | 323 | 370 | 136 | 172 | 172 | 742 | 242 | 180 |
| 0835 M110/2 | 80 | 80 | 167 | 88 | 340 | 200 | 265 | 715 | 280 | 823 | 323 | 370 | 136 | 172 | 172 | 742 | 242 | 180 |
| 0841 | 80 | 100 | 167 | 88 | 340 | 200 | 240 | 653 | 270 | 818 | 325 | 327 | 115 | 167 | 141 | 748 | 252 | 180 |
| 0842 | 80 | 100 | 167 | 88 | 340 | 200 | 240 | 653 | 270 | 818 | 325 | 327 | 115 | 167 | 141 | 748 | 252 | 180 |
| 0844 M70/2 | 80 | 100 | 167 | 88 | 342 | 200 | 230 | 689 | 258 | 787 | 330 | 300 | 102 | 154 | 140 | 729 | 272 | 218 |
| 0844 M110/2 | 80 | 100 | 167 | 88 | 342 | 200 | 230 | 739 | 258 | 787 | 330 | 300 | 102 | 154 | 140 | 729 | 272 | 218 |
| 1031 | 100 | 100 | 180 | 92 | 370 | 225 | 250 | 671 | 310 | 720 | 305 | 370 | 115 | 161 | 162 | 633 | 220 | 130 |
| 1032 | 100 | 100 | 180 | 92 | 370 | 225 | 250 | 731 | 323 | 747 | 320 | 362 | 113 | 180 | 180 | 649 | 222 | 130 |
| 1032 M90/4 | 100 | 100 | 180 | 92 | 370 | 225 | 250 | 781 | 323 | 747 | 320 | 362 | 113 | 180 | 180 | 649 | 222 | 130 |
| 1033 | 100 | 150 | 180 | 92 | 371 | 225 | 315 | 1158 | 330 | 787 | 391 | 475 | 91 | 252 | 212 | 682 | 286 | 204 |
| 1034 | 100 | 100 | 243 | 98 | 425 | 249 | 250 | 1104 | 325 | 725 | 398 | 370 | 137 | 180 | 180 | 649 | 322 | 210 |
| 1035 DN80 | 80 | 100 | 180 | 168 | 370 | 200 | 300 | 1071 | 290 | 540 | 358 | 370 | 135 | 173 | 173 | 450 | 268 | 218 |
| 1035 DN100 | 100 | 100 | 243 | 100 | 425 | 249 | 300 | 1071 | 339 | 540 | 358 | 370 | 184 | 173 | 173 | 450 | 268 | 218 |
| 1041 | 100 | 100 | 180 | 92 | 371 | 225 | 265 | 658 | 275 | 817 | 313 | 344 | 90 | 191 | 160 | 769 | 269 | 180 |
| 1042 | 100 | 100 | 180 | 92 | 371 | 225 | 265 | 731 | 285 | 845 | 345 | 367 | 74 | 212 | 168 | 786 | 286 | 180 |
| 1042 M90/4 | 100 | 100 | 180 | 92 | 371 | 225 | 265 | 781 | 285 | 845 | 345 | 367 | 74 | 212 | 168 | 786 | 286 | 180 |
| 1043 | 100 | 100 | 180 | 92 | 371 | 225 | 240 | 721 | 285 | 825 | 330 | 310 | 86 | 168 | 168 | 764 | 269 | 180 |
| 1045 | 100 | 150 | 180 | 92 | 371 | 225 | 315 | 1145 | 330 | 787 | 391 | 475 | 86 | 252 | 212 | 682 | 286 | 204 |
| 1048 | 100 | 100 | 243 | 98 | 425 | 249 | 270 | 1077 | 311 | 516 | 334 | 320 | 150 | 172 | 172 | 454 | 272 | 218 |
| 1049 | 100 | 100 | 180 | 92 | 371 | 225 | 280 | 717 | 308 | 831 | 369 | 370 | 112 | 214 | 171 | 748 | 286 | 218 |
| 1049 M90/4 | 100 | 100 | 180 | 92 | 371 | 225 | 280 | 767 | 308 | 831 | 369 | 370 | 112 | 214 | 171 | 748 | 286 | 218 |
| 1533 | 150 | 150 | 210 | 98 | 463 | 280 | 335 | 1166 | 383 | 795 | 423 | 470 | 136 | 278 | 220 | 692 | 320 | 228 |
| 1541 | 150 | 150 | 210 | 98 | 463 | 280 | 310 | 731 | 340 | 845 | 345 | 375 | 129 | 240 | 190 | 786 | 286 | 180 |
| 1541 M90/4 | 150 | 150 | 210 | 98 | 463 | 280 | 310 | 781 | 340 | 845 | 345 | 375 | 129 | 240 | 190 | 786 | 286 | 180 |
| 1543 | 150 | 150 | 210 | 98 | 463 | 280 | 335 | 1153 | 383 | 795 | 423 | 470 | 131 | 278 | 220 | 692 | 320 | 228 |
| 1546 | 150 | 150 | 210 | 98 | 463 | 280 | 310 | 731 | 340 | 845 | 383 | 370 | 130 | 240 | 190 | 786 | 324 | 218 |
| 1546 M90/4 | 150 | 150 | 210 | 98 | 463 | 280 | 310 | 781 | 340 | 845 | 383 | 370 | 130 | 240 | 190 | 786 | 324 | 218 |
| 2045 | 200 | 200 | 245 | 135 | 550 | 320 | 400 | 1192 | 442 | 834 | 488 | 470 | 151 | 328 | 241 | 712 | 366 | 254 |
| 2046 | 200 | 200 | 245 | 135 | 550 | 320 | 400 | 1192 | 442 | 834 | 488 | 470 | 151 | 328 | 241 | 712 | 366 | 254 |

DN1 = Discharge, DN2 = Suction.

Dimensions F, O, P, S measured from cast lifting eyelet available on request (for AFP-S and AFP without lifting hoop).

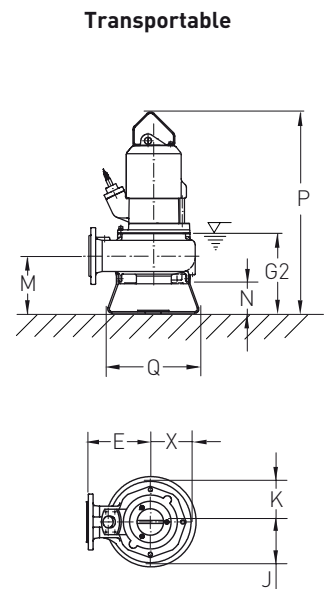
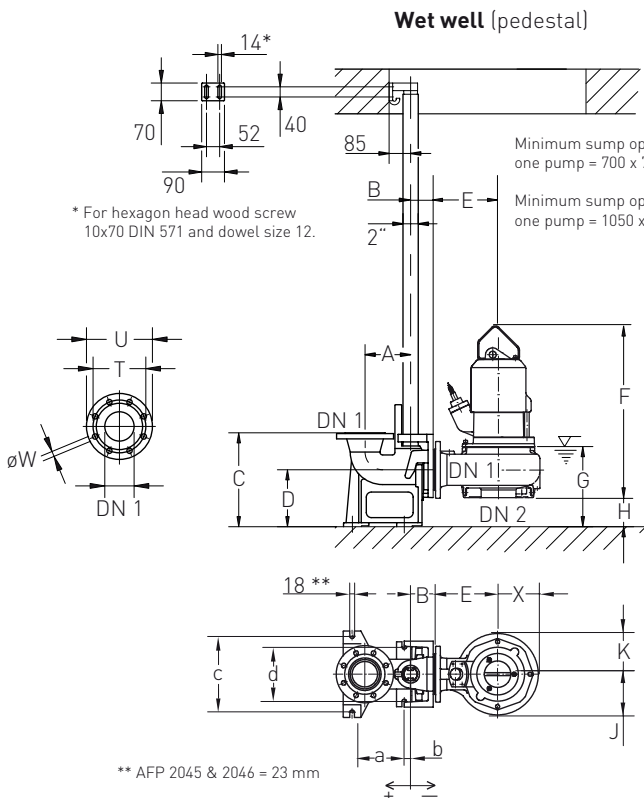

▽ = Lowest switch-off point
for automatic control.

| AFP | O | P | Q | R | S | T | U | W | X | Y | Z | a | b | c | d | e | f | g | h | j |
|--------------------|------|------|-----|-----|------|-----|-----|----|-----|------|-----|-----|------|-----|-----|-----|-----|-----|-----|----|
| 0831 | 1176 | 755 | 348 | 525 | 651 | 160 | 200 | 18 | 161 | 100 | 235 | 207 | +25 | 275 | 195 | 450 | 300 | 113 | 555 | 75 |
| 0832 M70/2 | 1221 | 866 | 348 | 525 | 696 | 160 | 200 | 18 | 161 | 100 | 235 | 207 | +25 | 275 | 195 | 450 | 300 | 113 | 621 | 75 |
| 0832 M40/2 | 1176 | 755 | 348 | 525 | 651 | 160 | 200 | 18 | 161 | 100 | 235 | 207 | +25 | 275 | 195 | 450 | 300 | 113 | 555 | 75 |
| 0834 | 1271 | 910 | 348 | 525 | 746 | 160 | 200 | 18 | 161 | 100 | 235 | 207 | +25 | 275 | 195 | 450 | 300 | 113 | 665 | 75 |
| 0835 | 1343 | 845 | 500 | 678 | 665 | 160 | 200 | 18 | 172 | 64 | 235 | 207 | +25 | 275 | 195 | 450 | 300 | 110 | 610 | 75 |
| 0835 M110/2 | 1393 | 895 | 500 | 678 | 715 | 160 | 200 | 18 | 172 | 64 | 235 | 207 | +25 | 275 | 195 | 450 | 300 | 110 | 660 | 75 |
| 0841 | 1287 | 793 | 425 | 580 | 707* | 160 | 200 | 18 | 155 | 167* | 200 | 207 | +25 | 275 | 195 | 365 | 250 | 115 | 552 | 72 |
| 0842 | 1287 | 793 | 425 | 580 | 707* | 160 | 200 | 18 | 155 | 167* | 200 | 207 | +25 | 275 | 195 | 365 | 250 | 115 | 552 | 72 |
| 0844 M70/2 | 1318 | 862 | 550 | 652 | 666* | 160 | 200 | 18 | 143 | 76* | 200 | 207 | +25 | 275 | 195 | 365 | 250 | 96 | 589 | 72 |
| 0844 M110/2 | 1368 | 912 | 550 | 652 | 716* | 160 | 200 | 18 | 143 | 76* | 200 | 207 | +25 | 275 | 195 | 365 | 250 | 96 | 639 | 72 |
| 1031 | 1196 | 765 | 348 | 525 | 671 | 180 | 225 | 18 | 161 | 110 | 235 | 230 | +25 | 300 | 215 | 450 | 300 | 123 | 576 | 75 |
| 1032 | 1268 | 841 | 348 | 537 | 731 | 180 | 225 | 18 | 180 | 112 | 235 | 230 | +25 | 300 | 215 | 450 | 300 | 137 | 655 | 75 |
| 1032 M90/4 | 1318 | 891 | 348 | 537 | 781 | 180 | 225 | 18 | 180 | 112 | 235 | 230 | +25 | 300 | 215 | 450 | 300 | 137 | 705 | 75 |
| 1033 | 1706 | 1310 | 682 | 575 | 1131 | 180 | 225 | 18 | 231 | 122 | 310 | 230 | +25 | 300 | 215 | 541 | 400 | 122 | 929 | 93 |
| 1034 | 1641 | 1314 | 520 | 537 | 1104 | 180 | 225 | 18 | 180 | 112 | 235 | 193 | -57 | 260 | 260 | 450 | 300 | 137 | 912 | 75 |
| 1035 DN80 | 1456 | 1274 | 605 | 385 | 1071 | 160 | 200 | 18 | 173 | 65 | 235 | 200 | -48 | 160 | 160 | 450 | 300 | 98 | 887 | 72 |
| 1035 DN100 | 1456 | 1274 | 605 | 385 | 1071 | 180 | 225 | 18 | 173 | 65 | 235 | 193 | -57 | 260 | 260 | 450 | 300 | 98 | 887 | 72 |
| 1041 | 1295 | 793 | 500 | 576 | 719* | 180 | 225 | 18 | 176 | 194* | 235 | 230 | +25 | 300 | 215 | 450 | 300 | 137 | 556 | 75 |
| 1042 | 1366 | 866 | 440 | 540 | 826* | 180 | 225 | 18 | 189 | 246* | 235 | 230 | +25 | 300 | 215 | 450 | 300 | 154 | 632 | 75 |
| 1042 M90/4 | 1416 | 916 | 440 | 540 | 876* | 180 | 225 | 18 | 189 | 246* | 235 | 230 | +25 | 300 | 215 | 450 | 300 | 154 | 682 | 75 |
| 1043 | 1346 | 851 | 425 | 581 | 765* | 180 | 225 | 18 | 168 | 183* | 200 | 230 | +25 | 300 | 215 | 365 | 250 | 131 | 616 | 72 |
| 1045 | 1688 | 1292 | 682 | 575 | 1113 | 180 | 225 | 18 | 231 | 107 | 310 | 230 | +25 | 300 | 215 | 541 | 400 | 122 | 911 | 93 |
| 1048 | 1432 | 1250 | 550 | 378 | 1054 | 180 | 225 | 18 | 172 | 76 | 200 | 193 | -57 | 260 | 260 | 365 | 250 | 96 | 857 | 72 |
| 1049 | 1352 | 890 | 605 | 663 | 689 | 180 | 225 | 18 | 193 | 35 | 235 | 230 | +25 | 300 | 215 | 450 | 300 | 116 | 625 | 75 |
| 1049 M90/4 | 1402 | 940 | 605 | 663 | 739 | 180 | 225 | 18 | 193 | 35 | 235 | 230 | +25 | 300 | 215 | 450 | 300 | 116 | 675 | 75 |
| 1533 | 1714 | 1342 | 682 | 575 | 1139 | 240 | 285 | 23 | 246 | 117 | 310 | 272 | -18 | 270 | 270 | 541 | 400 | 132 | 934 | 93 |
| 1541 | 1366 | 866 | 500 | 540 | 826* | 240 | 285 | 23 | 215 | 246* | 235 | 272 | -18 | 270 | 270 | 450 | 300 | 154 | 633 | 75 |
| 1541 M90/4 | 1416 | 916 | 500 | 540 | 876* | 240 | 285 | 23 | 215 | 246* | 235 | 272 | -18 | 270 | 270 | 450 | 300 | 154 | 683 | 75 |
| 1543 | 1696 | 1324 | 682 | 587 | 1109 | 240 | 285 | 23 | 246 | 106 | 310 | 272 | -18 | 270 | 270 | 541 | 400 | 132 | 919 | 93 |
| 1546 | 1366 | 904 | 605 | 616 | 750* | 240 | 285 | 23 | 215 | 171* | 235 | 272 | -18 | 270 | 270 | 450 | 300 | 154 | 639 | 75 |
| 1546 M90/4 | 1416 | 954 | 605 | 616 | 800* | 240 | 285 | 23 | 215 | 171* | 235 | 272 | -18 | 270 | 270 | 450 | 300 | 154 | 689 | 75 |
| 2045 | 1734 | 1389 | 682 | 567 | 1167 | 295 | 340 | 23 | 289 | 144 | 310 | 300 | -130 | 420 | 340 | 541 | 400 | 152 | 958 | 93 |
| 2046 | 1734 | 1389 | 682 | 567 | 1167 | 295 | 340 | 23 | 289 | 144 | 310 | 300 | -130 | 420 | 340 | 541 | 400 | 152 | 958 | 93 |

* Includes flange DIN 2633, PN 16; AFP 1546 includes 5" to DN150 adaptor flange.

Dry well vertical

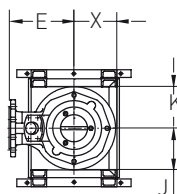
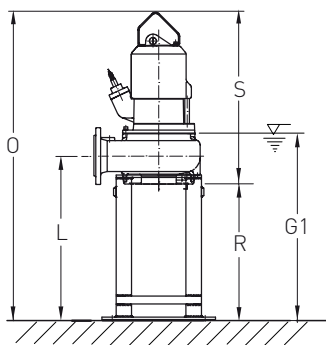

Dry well horizontal

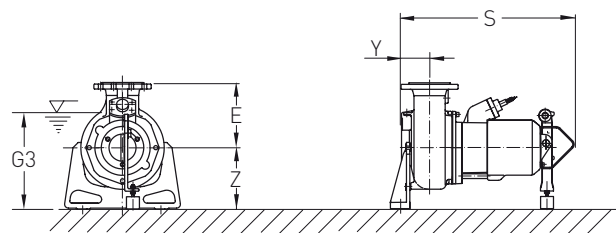

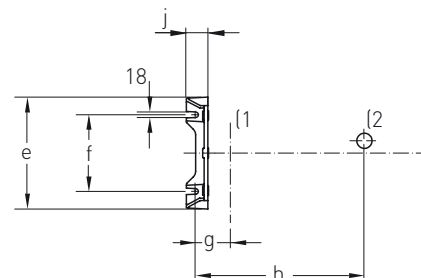

= Lowest switch-off point for automatic control

Volute Support (horizontal installation)

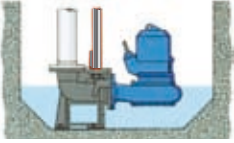
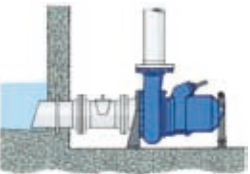
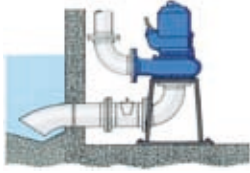

{1 = Centre of discharge line, {2 = Centre of head support

Accessories

| | Description | Size | Part no. | AFP | | |
|---|--|--|--|---------------------------------------|-----------|---|
| Fixed installation - wet well with ABS Automatic Coupling System  | Pedestal* (cast iron EN-GJL-250) 90° cast bend - plug/clamp connection (with fixing bolts) | DN 80 (pipe Ø90 mm) | 62320650 | 0831-0844 | | |
| | | DN 100 (pipe Ø109 mm) | 62320653 | 1031-1033, 1041-1045, 1049 | | |
| | | DN 100 high head (Ø109 mm) | 62325020 | 1034, 1035, 1048 | | |
| | | DN 100 (pipe Ø115 mm) | 62320654 | 1031-1033, 1041-1045, 1049 | | |
| | | DN 150 (pipe Ø160 mm) | 62320656 | 1533-1546 | | |
| | | DN 150 (pipe Ø169 mm) | 62320657 | 1533-1546 | | |
| | 90° cast bend - flange connection (fixing bolts not included) | DN 80 | 62320649 | 0831-0844 | | |
| | | DN 100 | 62320652 | 1031-1033, 1041-1045, 1049 | | |
| | | DN 100 (high-head) | 62325019 | 1034, 1035, 1048 | | |
| | | DN 150 | 62320655 | 1533-1546 | | |
| | | DN 200 | 62320658 | 2045 & 2046 | | |
| | | flange connection without bend (with fixing bolts) | DN 80 | 62320517 | 0831-0844 | |
| | | DN 100 | 62320516 | 1031-1045, 1049 | | |
| | | DN 150 | 62320537 | 1533-1546 | | |
| | Chain Kit (galvanized steel) including shackle | 3 m | 61265065 | 0831-2046 | | |
| 4 m | | 61265093 | | | | |
| 6 m | | 61265069 | | | | |
| 7 m | | 61265096 | | | | |
| Chain Kit (stainless steel) including shackle | | 3 m | 61265081 | | 0831-2046 | |
| | | 4 m | 61265099 | | | |
| | | 6 m | 61265085 | | | |
| | 7 m | 61265102 | | | | |
| Fixed installation - dry well, (horizontal)  | Pump Support Kit (EN-GJL-250) head and volute supports with fixing bolts and vibration damper | | 61820025 | 0841/M, 0842, 0844, 1043 | | |
| | | | 61820040 | 0831/M, 0832, 0834, 1031, 1041 | | |
| | | | 61820041 | 1032, 1042, 1049, 1541, 1546 | | |
| | | | 61825001 | 0831/S, 0841/S | | |
| | | | 61825007 | 1033, 1045, 1533 1543, 2045, 2046 | | |
| | | | 61825008 | 0835, 1034, 1035 | | |
| | | | 61825009 | 1048 | | |
| | | (vertical)  | Ground Support Stand | | 61355000 | 0831/M, 0832, 0834, 1031, 1032, 1034 |
| | | | | | 61355001 | 0835, 1041, 1042, 1049, 1541, 1546 |
| | | | | | 61355002 | 0831/S, 0841/S, 0841/M, 0842, 1043 |
| | 61355003 | | | 1033, 1045, 1533, 1543, 2045, 2046 | | |
| | 61355008 | | | 1035 | | |
| | 61355011 | 0844, 1048 | | | | |
| Transportable  | Ground Support Stand | | 61350525 | 0831/M, 0832, 0834, 1031, 1032 | | |
| | | | 61350526 | 0831/S, 0841/S, 0841/M, 0842, 1043 | | |
| | | | 61350527 | 0835, 1041, 1042, 1541 | | |
| | | | 61355004 | 1033, 1045 | | |
| | | | 61355005 | 1035, 1049 | | |
| | | | 61355006 | 1533, 1543 | | |
| | | | 61355007 | 2045, 2046 | | |
| | | | 61355009 | 1034 | | |
| | | | 61355010 | 0844, 1048 | | |
| | | General | Non-return Valve (EN-GJL-250) ball valve with inspection hatch | | 61400523 | 0831-0844 |
| | 61400524 | | | 1031-1049 | | |
| | 61400541 | | | 1533-1546 | | |
| ball valve with inspection hatch and venting screw | | | 61400534 | 0831-0844 | | |
| | | | 61400535 | 1031-1049 | | |
| | | | 61400542 | 1533-1546 | | |
| Gate Valve (EN-GJL-250) | | | 61420500 | 0831-0844 | | |
| | | | 61420501 | 1031-1049 | | |
| | | | 61420503 | 1533-1546 | | |
| | | | 61420504 | 2045 & 2046 | | |

* 2-inch guide rail not included

