

26 Fusion Machine

Fusion Capability for 2" IPS – 6" DIPS pipe (63mm – 180mm)



NEW!



PitBull® 26

The **PitBull 26** fuses 2" IPS to 6" DIPS and 2" IPS to 180mm depending upon model. Both models of the PitBull 26 come standard with a 6" IPS insert set.

The PitBull 26 incorporates the patented Centerline Guidance System, and is capable of butt fusing tees, ells and other fittings. The machine has a semi-automatic locking cam that maintains fusion during the cooling cycle and even fits on the Manual Fusion Machine Stand. An electric facer offers fast, efficient facing with an advanced blade design for smooth face offs and longer life.

- Semi-automatic locking cam
- Hard anodized aluminum wear surfaces for corrosion resistance
- Reversible jaws, clamp knobs, levers and facer allow operator to fuse from either side of the machine
- Thrust bearing equipped clamp knobs to minimize torque required to clamp and round pipe
- 17-to-1 mechanical advantage

26 Includes fusion machine, facer, heater, insulated heater stand, facer stand, 6" IPS insert set and screw/driver kit.

Model No.	Machine Size	Input Voltage Requirements	Min. Power Reqs. *	Plug Type **
A708502	6" DIPS	100V-120V, 50/60Hz, 1Ph	3 KVA, 2.5 KW	A
A708505	6" DIPS	220V-240V, 50/60Hz, 1Ph	3 KVA, 2.5 KW	C
A708504	180mm	220V-240V, 50/60Hz, 1Ph	3 KVA, 2.5 KW	C

* This is the minimum generator requirement at sea level, see your generator supplier or refer to the generator sizing form on page 145.

** Refer to the plug type reference chart on page 139 for your correct plug type.

26 Productivity Package

A708402 – 120V, 6" DIPS A708405 – 240V, 6" DIPS A708404 – 180mm

What you get: 1 PitBull 26, 1 Manual Fusion Stand and 2 PolyPorters

This package is for the contractor that wants to save time and money with the benefit of having all of these labor-saving devices in one cost-efficient package.

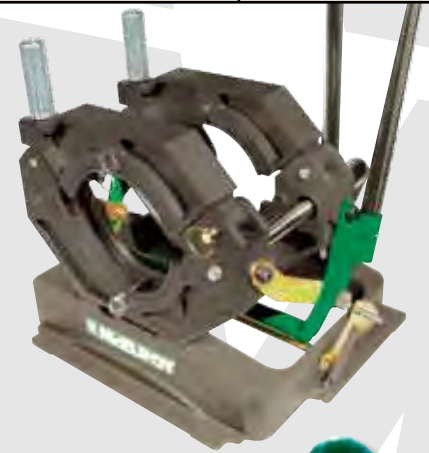
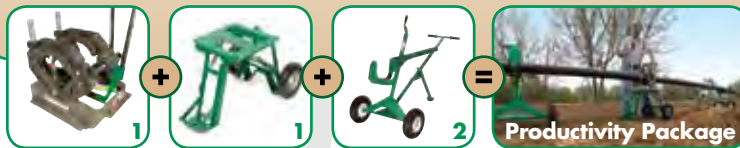

MACHINE PLUG TYPE
To find the right electrical plug type see **Page 139**

GENERATOR
To size your generator see **Page 145**



Visit the Fusion Experts at www.mcelroy.com



26

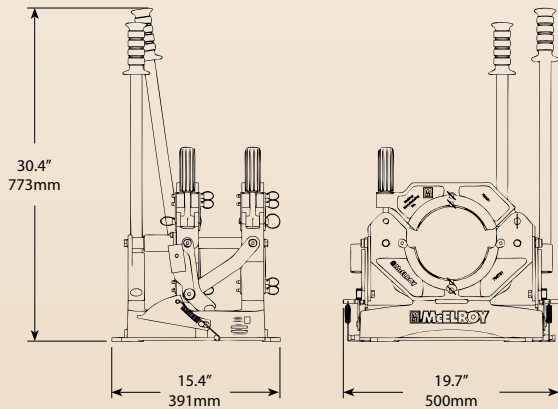

CAPACITY

Fuses Pipe Sizes: 2" IPS – 6" DIPS pipe (63mm – 180mm)

WEIGHT

Carriage: 50 lbs (22.7Kg)

Facer: 35 lbs (15.9Kg)

Heater: 14 lbs (6.4Kg)

POWER

Heater Power: 1200 Watt

120V Facer Power: 0.5HP, 7Amp, 120V

240V Facer Power: 1.6HP, 5Amp, 240V

WARRANTY

Term: 3 Years, see page 5 for details

Specifications subject to change without notice.
Additional dimensions available on page 143.

Part No.	Description
----------	-------------

Spare Heater Plate Kit



A707901

Plates have an anti-stick coating and are required for butt fusion. The kit includes 2 plates and attaching screws.

Spare Facer Blades



710602

Blade set includes 6 blades, attaching screws and wrench.

Spare Heaters - See legend below for more information.



Microprocessor-controlled with dial thermometer

A

707701

100V-120V, 50/60Hz, 100 Watt, 1Ph

C

707601

220V-240V, 50/60Hz, 100 Watt, 1Ph

Spare Facer - See legend below for more information.



A

709601

100V-120V, 50/60Hz, 1Ph

C

711601

220V-240V, 50/60Hz, 1Ph

Spare Facer Stand



711801

Facer stand provides a convenient place to protect and store your facer out of the dirt and mud.

Spare Heater Stand



712001

Holds heater for easier carrying and protection. Heater bag helps the heater maintain a constant temperature.

Pyrometer Kit



A218804

Accurately checks surface temperatures of heater.

Part No.	Description
----------	-------------

Torque Wrench Adapter



410802

Used to adapt a torque wrench to the 26 when a specified interfacial pressure is required. Requires a 1/2" Drive 100 ft.lb. 15" torque wrench.

Pipe Support Stand - See page 103 for more information



812501

For use with manual machine stand

Manual Fusion Machine Stand - See page 26



439001

Expands to a comfortable operator height equal to our other pipe supports. Folds for easy storage and has wheels for easy transporting.

Low Profile Rollers - To learn more, see page 104

NEW!



A1867501

Aids by reducing the drag on the pipe and protecting the pipe from damage. Case includes 40 complete roller assemblies.

PolyPorter™ - To learn more, see page 105



864201

Designed to aid in lifting of pipe into the fusion machine, as well as perform as a pipe stand.

PolyHorse™ - To learn more, see page 100

NEW!



1875502

PolyHorse with PowerAssist

1875501

Standard PolyHorse

Toolbox with Tray

NEW!



SW16001

For organizing your inserts and adapters for safe keeping.

PLUG TYPE LEGEND

See page 139 for more details.

A Plug type A

C Plug type C

26 Butt Fusion & Mitered Inserts

Butt Fusion Inserts

Our inserts have been surface-hardened for longer life. All inserts are serrated for maximum grip on the pipe. Inserts are made for one size pipe only. Not all inserts fit directly in the jaws. Some inserts nest inside other inserts, called master inserts.

For JIS insert sizes, see page 126.

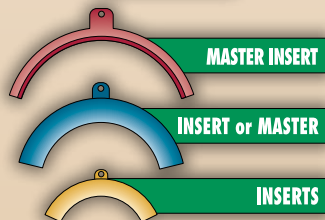
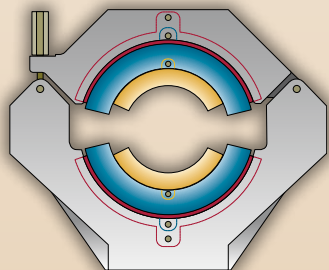

NOTE: Other sizes of inserts are available upon request. Contact your McElroy representative about inserts to fit your needs.

Butt Fusion Inserts Set = 4 Inserts

All inserts below fit in 6" DIPS 6.90" (175mm) Jaws

Inserts	Pipe OD	Set No.
6" IPS <i>Master</i>	6.63 (168mm)	Incl. w/Pkg.

All inserts below fit in 180mm jaws

6" IPS/180mm <i>Master</i>	6.63 (168mm)	Incl. w/ Pkg.
160mm/180mm	6.30 (160mm)	709310

All inserts below require 6" IPS/180mm or 6" IPS/DIPS Masters

5" IPS	5.56 (142mm)	809435
140mm	5.51 (140mm)	809439
5.375" OD	5.38 (137mm)	809437
5.25" OD	5.25 (133mm)	809436
125mm	4.92 (125mm)	809438
4" DIPS	4.80 (122mm)	809327
4" IPS/100mm JIS	4.50 (114mm)	809434
110mm	4.33 (110mm)	809324
3" DIPS	3.96 (101mm)	809326
90mm	3.54 (90mm)	809325
3" IPS	3.50 (89mm)	809323
75mm	2.95 (75mm)	809217
63mm	2.48 (63mm)	809216
2" IPS	2.38 (60mm)	809215

Manual Fusion Machine Stand

Overview

The Manual Fusion Machine Stand makes working with the 14, 2LC and 26 much easier. This stand expands to a comfortable operator level. The height corresponds to the McElroy pipe stands, PolyPorter™ and PolyHorse™ for easy pipe loading into the machine. When you are finished, it folds for easy storage and has wheels for transporting your machine to the next site.

Features

- Designed for use with the 14, 2LC and 26 fusion machines
- Compatible with McElroy pipe stands, PolyHorse and PolyPorter
- Locks in both folded and open positions
- More comfortable working height
- Wheels for easy transportation
- Folds for easy storage

Specifications

Weight – 50 lbs (23Kg)

Part No.

439001

