

1LC Fusion Machine Fusion Capability for 1/2" CTS – 1" IPS (16mm – 34mm)



1LC

The 1LC is the tool of choice for butt fusing 1/2" CTS to 1" IPS (16mm - 34mm) service sizes. As an alternative to the MiniMc™, the new 1LC offers a more conventional style of operation while maintaining the great features of the 2LC. McElroy engineers designed the heater to locate on the guide rods of the unit, similar to the entire line of McElroy fusion machines. The compact design allows for fusing in tight quarters.

- Patented Centerline Guidance System for equal distribution of force around the joint
- Locking cam to maintain force during the cooling cycle
- 3.8-to-1 mechanical advantage
- Conventional facer design features ball-bearing construction and gear drive for long life
- Jaws use same inserts as original MiniMc™
- Serrated jaws and inserts keep pipe from slipping during fusion process

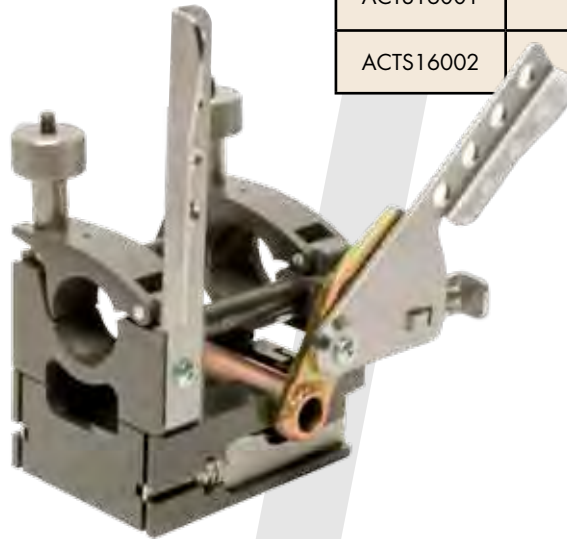

1LC

Includes fusion machine, heater, facer, insulated heater sling, ratchet wrench, screw/driver kit and case

Model No.	Input Voltage Requirements	Plug Type *
ACTS16001	100V-120V, 50/60Hz, 100 Watt, 1Ph	A
ACTS16002	200V-240V, 50/60Hz, 100 Watt, 1Ph	C

* Refer to the plug type reference chart on 139 for your correct plug type. Inserts sold separately.

MACHINE PLUG TYPE
To find the right electrical plug type see **Page 139**

GENERATOR
To size your generator see **Page 145**

ACCESSORIES
To find other related accessories see **Page 127**



Visit the Fusion Experts at www.mcelroy.com



1LC

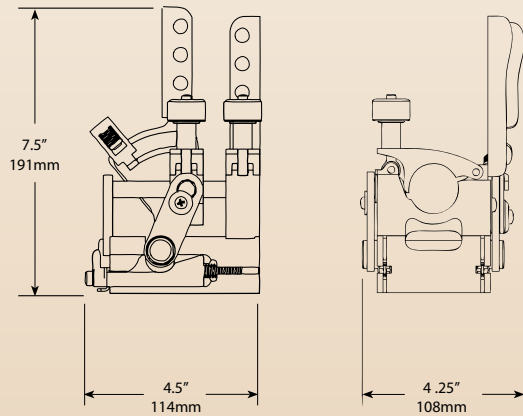

CAPACITY

Fuses Pipe Sizes: 1/2" CTS - 1" IPS (16mm - 34mm)

WEIGHT

Machine: 3 lbs (1.36Kg)

Facer: 1.8 lbs (.82Kg)

Heater: 2.5 lbs (1.13Kg)

POWER

Heater Power: 100 Watt

Facer Power: Hand-operated with 3/8" square drive

WARRANTY

Term: 3 Years, see page 5 for details

Specifications subject to change without notice.

Part No.	Description
----------	-------------

Spare Heaters - See legend below for more information.

	Microprocessor-controlled to maintain heater temperature.	
A	CTS20101	100V-120V, 50/60Hz, 100 Watt, 1Ph
C	CTS20001	200V-240V, 50/60Hz, 100 Watt, 1Ph

Spare Insulated Heater Sling

	CTS08301	Protects heater and helps maintain a constant temperature.
---	----------	--

Spare 1LC Facer

	CTS17601	Spare facer used to face pipe ends.
---	----------	-------------------------------------

Spare Facer Blade Set

	CTS21302	Blade set includes 2 blades, attaching screws and wrench.
---	----------	---

Spare Screw/Driver Kit

	ACTS08201	Spare driver kit with insert screws and wire brush for cleaning serrated jaws and inserts.
---	-----------	--

Tubing Shear

	MMD00009	Used to cut plastic tubing only, up to 1.7" OD capacity.
---	----------	--

Pyrometer Kit

	A218804	Accurately checks surface temperatures of heater.
---	---------	---

Part No.	Description
----------	-------------

Spare 1LC Case

	CTS15801	Our strong and durable carrying case will hold a 1LC, heater, heater sling, facer, and inserts.
---	----------	---

Butt Fusion Insert Set - Set = 4 inserts, screws and wrench

	Inserts are serrated for maximum grip and are made for one size pipe only. Inserts are required for pipe sizes less than 1" IPS.	
	CTS07101	1" CTS 1.13" OD
	CTS07201	3/4" IPS 1.05" OD
	CTS07301	3/4" CTS 0.88" OD
	CTS07401	1/2" IPS 0.84" OD
	CTS07501	1/2" CTS 0.63" OD
	CTS09201	25mm 0.98" OD
	CTS09101	20mm 0.79" OD

HEATER PLUG TYPE LEGEND

See page 139 for more details.

A Plug type A

C Plug type C