

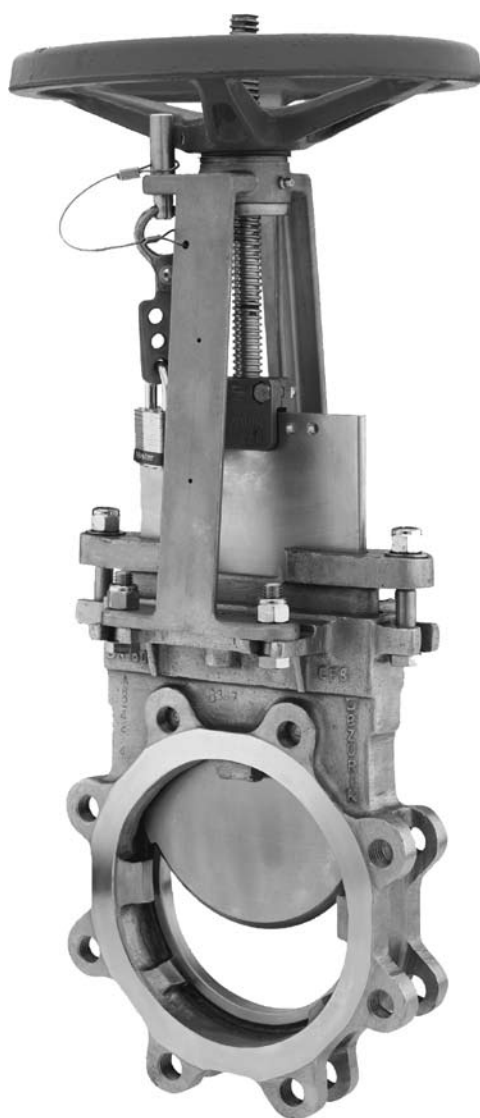

KGC CAST STAINLESS STEEL KNIFE GATE VALVES TECHNICAL SPECIFICATIONS



Materials of Construction

Item	Description	Material
A1	Body	304 Stainless Steel
		316 Stainless Steel
		317 Stainless Steel
		254 SMO Stainless Steel
		Alloy 20
		Hastelloy C 276
A2	Packing	General Service Packing Fiber to 500°F (260°C)
		Moderate/Severe Service Packing to 500°F (260°C)
		Severe Service with Atlas Rubber Cord to 400°F (204°C)
		Dry Service with Teflon Cord to 500°F (260°C)
		High Temperature Braided Packing to 650°F (343°C)
		High Temperature Braided Packing with Metal Scraper to 1000°F (540°C)
		Food Grade Service to 450°F (233°C)
A3	Gate	304 Stainless Steel
		316 Stainless Steel
		317 Stainless Steel
		254SMO
		Alloy 20
		Hastelloy C 276
		Hardened 17-4PH Stainless Steel
		420 Series Stainless Steel Sled
A4	Gland	Coated Carbon Steel Stainless Steel
A5	Bolt	Stainless Steel Carbon Steel Zinc Plated
A6	Washer	Stainless Steel Carbon Steel Zinc Plated
A7	Nut	Stainless Steel Carbon Steel Zinc Plated
A8	Packing Cord	Acrylic PTFE Coated
		Atlas
		PTFE
A9	Anti-Extrusion Ring	Glass-filled PTFE
		Carbon Graphite Fiber Composite
	Removable Seat	Chloroprene to 180°F (82°C)
		Acrylonitrile-Butadiene to 180°F (82°C)
		Chloro-Sulfonyl-Polyethylene to 200°F (93°C)
		Terpolymer of Ethylene, Propylene and a Diene to 250°F (121°C)
		Fluro Rubber to 400°F (204°C)
		Chloroprene, Off White to 140°F (60°C)
		17-4 pH Hardened Metal
B5	Yoke Sleeve	Aluminum Bronze
B7	Yoke	Stainless Steel
		Carbon Steel

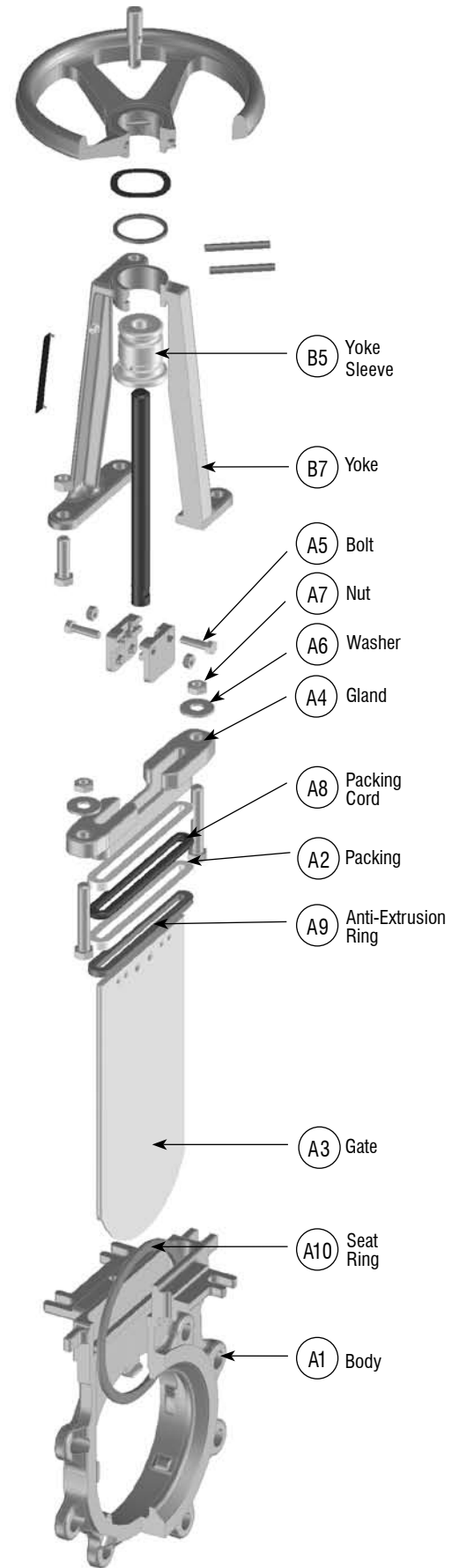

Applicable Standards

DeZURIK KGC Knife Gate Valves are designed and/or tested to meet the following standards:

TAPPI TIS 405-8	Recommendations for Stainless Steel, Bonnetless, Flanged, Wafer and Knife Gate Valves.
MSS SP-81— Metal Seated Valves	Stainless Steel, Bonnetless, Flanged Knife Gate Valves.
ANSI B16.5 — 2–24" (50–600mm)	Carbon Steel Flanges and Flanged Fittings, ANSI 150. Conforms to related drilling dimensions.
ANSI 16.47 — 30–36" (750–900mm)	Large diameter Steel Flanges. Series A. Conforms to related dimensions.
International Standards	Conforms to flanged bolt guides — JIS 10; DIN 10 and DIN 16; ISO 7005-1/PN10 and 7005-2/PN16; BS 4504/PN10 and BS 4504/PN16; and AS 2129 Tables D and E.

Valve Selection

Shut-Off Capabilities

Resilient Seats	Leak tight/drip tight
Metal Seats	Meet MSS-SP-81 and TAPPI TIS 405-8

Pressure Ratings

2-36" (50-900mm)	150 psi C.W.P. (1030 kPa)
------------------	---------------------------

Note: Valves with CRW seats are limited to 50 psi (350 kPa).
Contact DeZURIK with service conditions.

Cv/Kv Values, K Factors, Area of Opening

Valve Size	Cv* Kv* 100% Open	K Factor **	Area of Opening (in ² /cm ²)
2" 50mm	300 259	0.20	3.1 20
3" 80mm	675 584	0.18	7.1 46
4" 100mm	1200 1038	0.17	12.6 81
5" 125mm	1875 1622	0.16	19.6 127
6" 150mm	2700 2336	0.15	28.3 183
8" 200mm	4795 4148	0.14	50.3 325
10" 250mm	7494 6479	0.13	78.5 506
12" 300mm	10790 9334	0.13	113.1 730
14" 350mm	13150 11375	0.13	137.9 890
16" 400mm	17420 15069	0.12	182.7 1179
18" 450mm	22290 19282	0.12	261.6 1688
20" 500mm	27760 24014	0.12	291.0 1878
24" 600mm	40495 35030	0.11	424.6 2740
30" 750mm	64090 55441	0.11	672.0 4336
36" 900mm	93080 80519	0.10	975.9 6297

* Cv = Flow in GPM of water at 1 psi pressure drop.
Kv = Flow in m³/hr. of water at 100 kPa pressure drop.

** The equivalent length of pipe may be calculated according to the following formula:

$$L = \frac{K \times D}{f}$$

Where

- L = Equivalent length of pipe in feet
- K = K factor - Resistance coefficient of valve
- D = Pipe diameter in feet
- f = Friction factor, relating to type of pipe

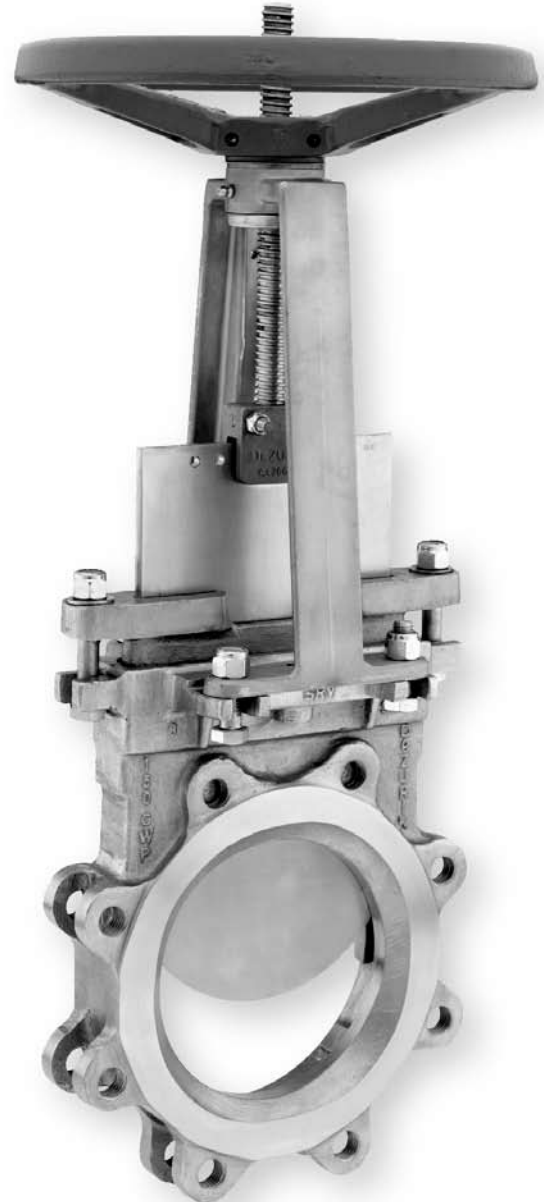

Valve Selection (continued)

Valve & Actuator Weights

Valve Size	Basic Valve	Add for Lever	Add for Handwheel	Add for Chainwheel	Add for Bevel Gear w/ Handwheel*	Add for Cylinder
2" 50mm	10 4.5	20 9	20 9	32 14.5	-	4" = 29 13
3" 80mm	16 7	37 17	27 12	39 18	88 40	4" = 37 17
4" 100mm	24 11	48 22	36 16	48 22	96 43.5	4" = 45 20
						6" = 63 29
5" 125mm	32 14.5	60 27	51 23	66 30	108 49	4" = 58 26
						6" = 76 35
						8" = 88 40
6" 150mm	38 17	66 30	57 26	75 34	113 51	4" = 63 29
						6" = 81 37
						8" = 93 42
8" 200mm	65 30	98 44.5	86 39	101 46	144 65	6" = 112 51
						8" = 124 56
10" 250mm	103 47	157 71	141 64	179 81	191 87	6" = 159 72
						8" = 174 79
						10" = 220 100
						12" = 258 117
12" 300mm	148 67	213 97	187 85	227 103	241 109	8" = 225 102
						10" = 270 122
						12" = 309 140
14" 350mm	199 90	-	265 120	284 129	303 137	8" = 282 128
						10" = 332 151
						12" = 372 169
16" 400mm	272 123	-	341 155	358 162	380 172	8" = 359 163
						10" = 409 186
						12" = 449 204
						14" = 495 225
18" 450mm	361 164	-	433 197	449 204	473 215	10" = 509 231
						12" = 551 250
						14" = 602 273
						16" = 813 369
20" 500mm	518 235	-	593 269	653 296	637 289	10" = 670 304
						12" = 712 323
						14" = 760 345
						16" = 982 445
24" 600mm	725 329	-	803 364	-	882 400	12" = 947 430
						14" = 1001 454
						16" = 1219 553
						18" = 1282 572
30" 750mm	1446 656	-	-	-	1595 723	12" = 1692 767
						14" = 1768 802
						16" = 1985 900
						18" = 2205 1000
36" 900mm	2204 1000	-	-	-	2366 1073	20" = 2365 1073
						14" = 2541 1153
						16" = 2755 1250
						18" = 2987 1355
						20" = 3150 1428

Pounds
Kilograms

Note: Weights are approximate and do not include crating.

* For Bevel Gear with Chainwheel, add the following weight to the bevel gear with handwheel weight:
 2-18" and 24" add 7 lbs. (3kg)
 20" add 26 lbs. (12kg)
 30" add 74 lbs. (34kg)
 36" add 68 lbs. (31kg)

Ordering

To order, simply complete the valve order code from information shown. An ordering example is shown for your reference.

Valve Style

Give body style code as follows:

KGC = Cast Knife Gate Valve

Valve Size

Give size code as follows:

2 = 2" (50mm)	14 = 14" (350mm)
3 = 3" (80mm)	16 = 16" (400mm)
4 = 4" (100mm)	18 = 18" (450mm)
5 = 5" (125mm)	20 = 20" (500mm)
6 = 6" (150mm)	24 = 24" (600mm)
8 = 8" (200mm)	30 = 30" (750mm)
10 = 10" (250mm)	36 = 36" (900mm)
12 = 12" (300mm)	

Body Style

Give body style code as follows:

GV = General Service Valve (Stainless Steel Packing Gland/Plated Fasteners with Carbon Steel Yoke/Plated Fasteners)
MV = Moderate Service Valve (Stainless Steel Packing Gland/Fasteners with Carbon Steel Yoke/Plated Fasteners)
SV = Severe/Corrosive Service Valve (Stainless Steel Packing Gland/Fasteners with Stainless Steel Yoke/Fasteners)

End Connections

Give end connection code as follows:

Standard ANSI Drilling
F1 = ANSI
Optional
F1T = ANSI Through Bolting
International Drilling
F110 = ISO 7005/PN10 Drilling
F116 = ISO 7005/PN16 Drilling
F1J1 = JIS 10 Drilling
F1DA = AS2129, Table D Drilling
F1EA = AS2129, Table E Drilling

Body Material

Give body material code as follows:

S1 = 304 Stainless Steel (GV and MV body styles)
S2 = 316 Stainless Steel (MV and SV body styles)
S3 = 317 Stainless Steel (SV body style only)
Non-standard
S6 = 254 Stainless Steel (SV body style only)
AA = Alloy 20 (SV body style only)
HC = Hastelloy C (SV body style only)

Packing Material

Give packing material code as follows:

All packing systems (except HTP, HMP, MSP and FGP) come with glass filled PTFE anti-extrusion ring. High temperature packing system (HTP) has carbon graphite fiber composite anti-extrusion ring. FGP, MSP and HMP options do not have an anti-extrusion ring in packing system.

Standard Packing

SMP = Standard Moderate Service Packing to 500°F (260°C)
MSP = Standard General Service Packing to 500°F (260°C)

Optional Packings

ASP = Severe Service with Aflas Rubber Cord to 400°F (204°C)
TDP = Dry Service with PTFE Cord to 500°F (260°C)
HTP = High Temperature Braided Packing to 650°F (343°C)
HMP = High Temperature Braided Packing with Metal Scraper to 1000°F (540°C)
FGP = Food Grade Packing to 450°F (233°C)

Note: The limiting factor in valve selection is the lowest temperature of the packing or seat.

Gate Material

Give gate material code as follows:

S1 = 304 Stainless Steel (Standard for GV and MV models and S1 body)
S2 = 316 Stainless Steel (Standard for MV and SV models with S2 body)
S3 = 317 Stainless Steel (Standard for SV model with S3 body)
Non-standard
S6 = 254 SMO Stainless Steel (SV model and S6 body only)
AA = Alloy 20 (SV model and AA body only)
HC = Hastelloy C (SV model and HC body only)
S5 = Hardened 17-4 PH Stainless Steel
S8 = 420 Series Stainless Steel

Seat Material

Give seat material code as follows:

Standard

M = Integral Metal Seat (same as body material)
V = V-Orifice Metal Seat
CR = Chloroprene to 180°F (82°C)
NBR = Acrylonitrile-Butadiene to 180°F (82°C)
CSM = Chloro-Sulfonyl-Polyethylene to 200°F (93°C)
EPDM = Terpolymer of Ethylene, Propylene and a Diene to 250°F (121°C)
Optional Seats
FKM = Fluoro Rubber to 400°F (204°C)
CRW = Chloroprene, Off-White to 140°F (60°C) (Use with SMP packing only)
S5D = 17-4 PH Hardened Seat, Replaceable Drop-in

Note: The limiting factor in valve selection is the lowest temperature of the packing or seat. See DeZURIK Material Selection Guide software for elastomer recommendations.

Standard Options

Give options as follows:

PSA = Purge Ports in Seat Area
PCA = Purge Ports in Chest Area
PSC = Purge Ports in Seat and Chest Area
CRT = Certified Physical and Chemical Test Report per QY00006

Ordering Examples:

KGC,6,GV,F1,S1,MSP,S1-EPDM*Actuator
KGC,6,MV,F116,S1,SMP,S1-M*Actuator
KGC,6,SV,F1,S3,SMP,S3-M*Actuator

Manual Actuators

Lever Actuators

Lever actuators can be furnished on 2–12" (50–300mm) valves for applications where rapid valve operation is required or where space prevents use of a standard handwheel or bevel gear actuator. Maximum pressure differential required for valves with lever actuators should not exceed the limits listed. Maximums are based on the operating force for each valve size. To order, add the lever actuator code to the basic valve order code.

Lever Actuator

Valve Size	Order Code	Max. Pressure Differential psi/kPa
2-4" 50-100mm	MN-LV	75 520
5-6" 125-150mm	MN-LV	45 310
8" 200mm	MN-LV	25 170
10" 250mm*	MN-LV	20 140
12" 300mm*	MN-LV	14 100

Lever operated valves must be ordered with SMP packing.

Ordering Example:

KGC,4,GV,F1,S1,SMP,S1-M*MN-LV

Handwheel and Chainwheel Actuators

All 2–24" (50–600mm) valves can be furnished with handwheel actuators, and 2–20" (50–500mm) with chainwheel actuators. Bevel gear actuators are available on 3–36" (80–900mm) valves with handwheel or chainwheel actuators.

To order handwheel or chainwheel actuators, add the appropriate order code to the basic valve order code. Refer to information on bevel gear actuators for use on dry solids, paper stock, slurries or when pressure exceeds limits shown. Order chain for chainwheel actuators as a separate item.

Chainwheel Actuator

Valve Size	Order Code	Max. Pressure Differential psi/kPa
2-4" 50-100mm	MN-CW8	150 1030
5-8" 125-200mm	MN-CW12	150 1030
10-12" 250-300mm	MN-CW20	150 1030
14" 350mm	MN-CW20	125* 860*
16" 400mm	MN-CW20	100* 690*
18" 450mm	MN-CW20	75* 520*
20" 500mm	MN-CW30	50* 340*

*Bevel gear actuators are recommended when pressure exceeds limits shown.

Handwheel Actuator

Valve Size	Order Code	Max. Pressure Differential psi/kPa
2-4" 50-100mm	MN-HD8	150 1030
5-8" 125-200mm	MN-HD12	150 1030
10 & 12" 250 & 300mm	MN-HD16	150 1030
14" 350mm	MN-HD20	125* 860*
16" 400mm	MN-HD20	100* 690*
18" 450mm	MN-HD20	75* 520*
20" 500mm	MN-HD20	50* 340*
24" 600mm	MN-HD20	25* 170*

*Bevel gear actuators are recommended when pressure exceeds limits shown.

Bevel Gear Actuators

Bevel gear actuators provide vertical mounting of the handwheel or chainwheel, or can be used where space limitations prohibit the use of a standard handwheel or chainwheel. A mechanical advantage makes large valve operation easier and faster.

Actuator Mounting

Bevel gears can be mounted at standard, 90, 180 or 270 degree mounting. To order, use the appropriate order code from the chart for standard or 180 degree mounting, or 90 or 270 degree mounting. Specify which position as second line information.

Bevel Gear Handwheel Actuator

Valve Size	Order Code		Max. Pressure Differential psi/kPa
	Std./180 Mounting	90/270 Mounting	
3-12" 80-300mm	MNB-HD12	MNB-HD12	150 1030
14-18" 350-450mm	MNB-HD12	MNB-HD12-A	150 1030
20" & 24" 500-600mm	MNB-HD16	MNB-HD16-A	150 1030
30" 750mm	MNB-HD30	MNB-HD24-A	150 1030
36" 900mm	MNB-HD30	MNB-HD24-A	150 1030

Ordering Example:

KGC,14,SV, F1,S2,SMP,S2-M*MNB-HD12
Actuator mounted 90 from standard.

Bevel Gear Chainwheel Actuator

Valve Size	Order Code		Max. Pressure Differential psi/kPa
	Std./180 Mounting	90/270 Mounting	
3-12" 80-300mm	MNB-CW12	MNB-CW12	150 1030
14-18" 350-450mm	MNB-CW12	MNB-CW12-A	150 1030
20" & 24" 500-600mm	MNB-CW20	MNB-CW20-A	150 1030
30" & 36" 750 - 900mm	MNB-CW30	MNB-CW30-A	150 1030

Ordering Example:

KGC,14,SV, F1,S2,SMP,S2-M*MNB-CW12

Accessories — Manual Actuators

Chain

Chain for use with chainwheel actuators. Order as a separate item by giving code from table and specifying length of chain as second line information. Order as a separate item.

Chain Type	Order Code
Standard 316	ACC*CN102
Galvanized	ACC*CN103
304 Stainless Steel	ACC*CN106

Ordering Example:

ACC*CN102

Chain 12 feet long (366cm)

Handwheel-2" Nut Extension

Provides extension of the handwheel or nut to allow remote operation - normally from above. The extension includes fittings and extension pipe with handwheel or nut mounted. To order, specify description and extension length from center line of valve to handwheel or nut.

Ordering Example:

KGC,14,SV,F1,S2,SMP,S2-CR*MN-HD20, ENHD

KGC,14,SV,F1,S2,SMP,S2-CR*MN-HD20, ENTS

Center line of valve to handwheel nut 72 inches (1829mm).

Locking Device

Available on all sizes of handwheel and bevel gear handwheel operated valves. To order, add a comma and the order code "LK" after the actuator code.

Ordering Example:

KGC,14,SV,F1,S2,SMP,S2-CR*MNB-HD12,LK

Floorstand

A floorstand for handwheel actuated valves allows operation from above. Includes floorstand with gate position indicator, handwheel, fittings and extension. To order, specify length from center line of valve to base of floorstand. This dimension must be at least twice the dimension from center line to handwheel. For non-rising stems only. Rising stems O/A.

Ordering Example:

KGC,14,SV,F1,S2,SMP,S2-CR*MN-HD20

Except with floorstand. Center line of valve to base of floorstand 72 inches (1829mm).

Deflection Cones

To prolong valve life in particularly demanding services, deflection cones are available in 316 stainless steel or cast Ni-Hard. Order as a separate line item by giving the correct code and valve size.

Ordering Example:

ACC*DCS21-12 316SST Cone for 12" valve

Cylinder Actuators

On-Off Cylinder Actuators

DeZURIK cylinder actuators are available with double-acting pneumatic or hydraulic cylinders for on/off or positioning services. Supply pressure is 50 or 80 psi (340 or 550 kPa). To order, add the proper code from the on/off column of the table to the valve order code. Specify hydraulic media if other than oil.

Positioning Cylinder Actuators

DeZURIK cylinder actuators are available with pneumatic or electronic positioners for throttling control. Positioners are enclosed and mounted on the superstructure.

Actuator Sizing

50 psi (340 kPa) Air Supply

Valve Size	Actuator Order Code	Max. Pressure Differential psi/kPa			
		On/Off		Positioning	
		Dry Solids, Slurries, Paper Stock	Liquids & Gases	Dry Solids, Slurries, Paper Stock	Liquids & Gases
2 & 3" 50 & 80mm	CY-PC4	75 520	150 1030	75 520	150 1030
4" 100mm	CY-PC4	75 520	150 1030	—	150 1030
	CY-PC6	—	—	75 520	—
5 & 6" 125 & 150mm	CY-PC4	—	150 1030	—	25 170
	CY-PC6	75 520	—	—	150 1030
8" 200mm	CY-PC6	—	150 1030	—	25 170
	CY-PC8	75 520	—	75 520	150 1030
10" 250mm	CY-PC6	—	50 340	—	—
	CY-PC8	—	150 1030	—	25 170
	CY-PC10	75 520	—	—	50 340
	CY-PC12	—	—	75 520	150 1030
12" 300mm	CY-PC8	—	100 690	—	25 170
	CY-PC10	—	150 1030	—	50 340
	CY-PC12	75 520	—	75 520	150 1030
14" 350mm	CY-PC8	—	50 340	—	—
	CY-PC10	—	100 690	—	25 170
	CY-PC12	75 520	150 1030	75 520	150 1030
16" 400mm	CY-PC8	—	25 170	—	—
	CY-PC10	—	75 520	—	—
	CY-PC12	75 520	150 1030	—	75 520
	CY-PC14	—	—	75 520	150 1030
18" 450mm	CY-PC10	—	50 340	—	—
	CY-PC12	75 520	150 1030	—	25 170
	CY-PC14	—	—	75 520	75 520
	CY-PC16	—	—	—	150 1030

Valve Size	Actuator Order Code	Max. Pressure Differential psi/kPa			
		On/Off		Positioning	
		Dry Solids, Slurries, Paper Stock	Liquids & Gases	Dry Solids, Slurries, Paper Stock	Liquids & Gases
20" 500mm	CY-PC10	—	25 170	—	—
	CY-PC12	—	75 520	—	—
	CY-PC14	75 520	150 1030	—	50 340
	CY-PC16	—	—	75 520	150 1030
24" 600mm	CY-PC12	—	50 340	—	—
	CY-PC14	—	100 690	—	—
	CY-PC16	75 520	150 1030	—	50 340
30" 750mm	CY-PC18	—	—	75 520	150 1030
	CY-PC12	—	25 170	—	—
	CY-PC14	—	75 520	—	—
	CY-PC16	—	100 690	—	—
	CY-PC18	—	125 860	—	25 170
	CY-PC20	75 520	—	75 520	75 520
36" 900mm	CY-PC14	—	25 170	—	—
	CY-PC16	—	75 520	—	—
	CY-PC18	—	100 690	—	25 170
	CY-PC20	75 520	125 860	75 520	75 520

Cylinder Actuators (continued)

Actuator Sizing
80 psi (550 kPa) Air Supply

Valve Size	Actuator Order Code	Max. Pressure Differential psi/kPa			
		On/Off		Positioning	
		Dry Solids, Slurries, Paper Stock	Liquids & Gases	Dry Solids, Slurries, Paper Stock	Liquids & Gases
2 & 3" 50 & 80mm	CY-PC4	75 520	150 1030	75 520	150 1030
	CY-PC6	—	—	75 520	—
4" 100mm	CY-PC4	75 520	150 1030	—	150 1030
	CY-PC6	—	—	75 520	—
5 & 6" 125 & 150mm	CY-PC4	—	150 1030	—	25 170
	CY-PC6	75 520	—	—	150 1030
	CY-PC8	—	—	75 520	—
8" 200mm	CY-PC4	—	150 1030	—	25 170
	CY-PC6	75 520	150 1030	—	25 170
	CY-PC8	—	—	75 520	150 1030
10" 250mm	CY-PC6	—	125 860	—	—
	CY-PC8	75 520	150 1030	—	50 340
	CY-PC10	—	—	—	100 690
12" 300mm	CY-PC12	—	—	75 520	150 1030
	CY-PC8	75 520	150 1030	—	50 340
	CY-PC10	—	—	—	100 690
14" 350mm	CY-PC12	—	—	75 520	150 1030
	CY-PC8	—	125 860	—	—
	CY-PC10	75 520	150 1030	—	75 520
16" 400mm	CY-PC12	—	—	75 520	150 1030
	CY-PC8	—	100 690	—	—
	CY-PC10	75 520	150 1030	—	—
	CY-PC12	—	—	—	100 690
18" 450mm	CY-PC14	—	—	75 520	150 1030
	CY-PC10	75 520	150 1030	—	—
	CY-PC12	—	—	—	50 340
	CY-PC14	—	—	75 520	75 520
	CY-PC16	—	—	—	150 1030

Valve Size	Actuator Order Code	Max. Pressure Differential psi/kPa			
		On/Off		Positioning	
		Dry Solids, Slurries, Paper Stock	Liquids & Gases	Dry Solids, Slurries, Paper Stock	Liquids & Gases
20" 500mm	CY-PC10	—	125 860	—	—
	CY-PC12	75 520	150 1030	—	—
	CY-PC14	—	—	340	50
	CY-PC16	—	—	75 520	150 1030
24" 600mm	CY-PC12	75 520	150 1030	—	—
	CY-PC16	—	—	—	50 340
	CY-PC18	—	—	75 520	150 1030
30" 750mm	CY-PC12	—	100 690	—	—
	CY-PC14	—	125 860	—	—
	CY-PC16	—	—	—	25 170
	CY-PC18	—	—	—	75 520
36" 900mm	CY-PC20	75 520	—	75 520	—
	CY-PC14	—	100 690	—	—
	CY-PC16	75 520	125 860	—	—
	CY-PC18	—	—	—	25 170
	CY-PC20	—	—	75 520	75 520

Electric Motor Actuators

DeZURIK KGC Knife Gate Valves can be furnished with electric motor actuators including Limatorque Auma, Rotork, E.I.M. and others.

Ordering

When ordering electric motor actuators, specify valve order code, shutoff pressure, service conditions — flowing media and installation direction; type of application — on/off or throttling; speed of operation; NEMA rating — 4, 7, submersible, etc.; electrical characteristics — voltage and phase; actuator accessories and controls as per specification requirements.

Basic Valve Dimensions

Valve Size	Dimensions													
	A	B	C	D	E	F	G	H	J	K	L	M	N	P
2" 50mm	4.75 121	5/8-11 UNC	2	2	.52 13	3.00 76	.50 13	1.88 48	4.00 102	6.50 165	8.12 206	5.69 145	3.97 101	1.38 35
3" 80mm	6.00 152	5/8-11 UNC	2	2	.52 13	3.75 95	.50 13	2.00 51	4.75 121	8.00 203	9.91 252	6.47 164	4.72 120	1.88 48
4" 100mm	7.50 191	5/8-11 UNC	6	2	.52 13	4.50 114	.50 13	2.00 51	5.00 127	10.00 254	12.19 310	7.75 197	5.69 145	1.88 48
5" 125mm	8.5 216	3/4-10 UNC	6	2	.61 15	5.00 127	.62 16	2.25 57	5.75 146	10.50 267	13.56 344	9.12 232	6.38 162	2.25 57
6" 150mm	9.50 241	3/4-10 UNC	6	2	.56 14	5.50 140	.62 16	2.25 57	5.75 146	11.75 298	16.12 409	9.69 246	6.94 176	2.25 57
8" 200mm	11.75 298	3/4-10 UNC	6	2	.61 15	6.75 171	.62 16	2.75 70	6.38 162	14.38 365	20.69 526	12.25 311	9.56 243	2.25 57
10" 250mm	14.25 362	7/8-9 UNC	8	4	.67 17	8.00 203	.75 19	2.75 70	8.25 210	16.75 425	25.50 648	14.88 378	11.69 297	2.50 64
12" 300mm	17.00 432	7/8-9 UNC	8	4	.67 17	9.50 241	.75 19	3.00 76	8.25 210	19.62 498	29.53 750	16.91 430	13.22 336	2.50 64
14" 350mm	18.75 476	1-8 UNC	8	4	.69 18	10.50 267	.81 21	3.00 76	8.25 210	21.88 556	32.44 824	18.50 470	15.19 386	2.50 64
16" 400mm	21.25 540	1-8 UNC	10	6	.75 19	11.75 298	.88 22	3.50 89	8.69 221	24.38 619	36.06 916	20.00 508	16.69 424	3.25 83
18" 450mm	22.75 578	1-1/8-7 UNC	10	6	.78 20	12.50 318	.94 24	3.50 89	9.06 230	25.88 657	41.06 1043	23.00 584	19.44 494	3.25 83
20" 500mm	25.00 635	1-1/8-7 UNC	12	8	.85 22	13.75 349	1.00 25	4.50 114	9.19 233	28.38 721	44.94 1141	24.88 632	21.31 541	3.66 93
24" 600mm	29.50 749	1-1/4-7 UNC	12	8	.85 22	16.00 406	1.00 25	4.50 114	9.19 233	32.88 835	52.81 1341	28.75 730	25.19 640	3.66 93
30" 750mm	36.00 914	1-1/4-7 UNC	16	12	.85 22	19.38 492	1.12 28	5.50 140	11.25 286	39.62 1006	65.56 1665	35.50 902	31.44 799	4.44 113
36" 900mm	42.75 1086	1-1/2-6 UNC	18	14	.97 25	23.00 584	1.12 28	6.00 152	11.25 286	47.89 1216	77.25 1962	41.19 1046	37.19 945	4.44 113

Inches

Millimeters

Valve Size	Dimensions										
	R	S	T	U	V	W	X	Y	Z	AA	BB
2" 50mm	1.31 33	.44 11	.20 5	2.88 73	.50 13	.44 11	.41 10	—	—	—	—
3" 80mm	1.69 43	.44 11	.28 7	3.88 99	.50 13	.50 13	.41 10	1.40 36	.25 6	—	.28 7
4" 100mm	1.81 46	.44 11	.28 7	4.99 124	.50 13	.50 13	.41 10	1.79 45	.25 6	—	.28 7
5" 125mm	2.12 54	.56 14	.28 7	5.88 149	.50 13	.50 13	.41 10	1.41 36	.38 10	.62 16	.28 7
6" 150mm	2.12 54	.56 14	.31 8	6.75 171	.50 13	.50 13	.41 10	1.41 36	.38 10	.62 16	.28 7
8" 200mm	2.50 64	.56 14	.41 10	9.00 229	.50 13	.50 13	.41 10	3.42 87	.38 10	.62 16	.28 7
10" 250mm	3.19 81	.69 18	.47 12	11.25 286	.88 22	.62 16	.53 13	4.29 109	.38 10	.62 16	.28 7
12" 300mm	3.12 79	.69 18	.58 15	13.25 337	.88 22	.62 16	.53 13	4.91 125	.31 8	.62 16	.28 7
14" 350mm	3.19 81	.69 18	.62 16	14.62 371	.88 22	.62 16	.53 13	5.41 137	.38 10	.62 16	.28 7
16" 400mm	3.41 87	.69 18	.71 18	17.00 432	.88 22	.62 16	.53 13	5.41 137	.38 10	.62 16	.28 7
18" 450mm	3.59 91	.69 18	.80 20	19.00 483	.88 22	.62 16	.53 13	7.16 182	.38 10	.62 16	.28 7
20" 500mm	3.66 93	.69 18	.87 22	21.00 533	.88 22	.62 16	.53 13	8.41 214	.38 10	.62 16	.28 7
24" 600mm	3.66 93	.69 18	1.00 25	25.00 635	.88 22	.66 17	.53 13	10.25 260	.38 10	.62 16	.28 7
30" 750mm	4.56 116	.81 21	1.26 32	31.00 787	1.25 32	.88 22	.78 20	13.53 344	.50 13	.62 16	.28 7
36" 900mm	4.56 116	.81 21	1.52 39	37.25 946	1.25 32	1.06 27	.78 20	16.53 420	.38 10	.62 16	.28 7

Inches

Millimeters

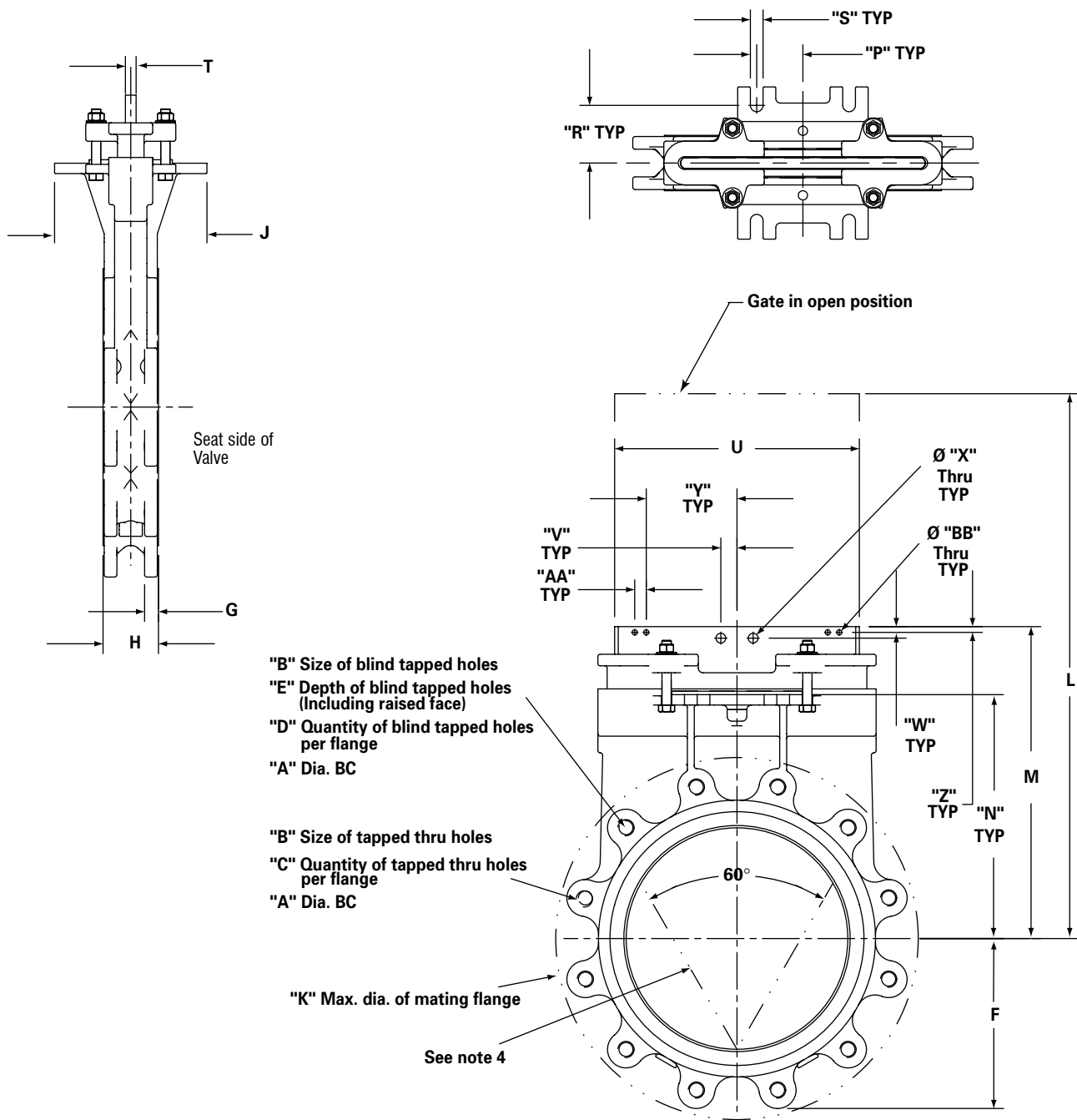

Note:

1. Valve is shown in closed position.
2. Valve ordered with thru bolting have all holes, except those that are blind tapped. Drilled to ANSI standards Class 125 & 150.
3. Drawing shows flange drillings for use with ANSI flanges, for use with other than ANSI flanges, see DeZURIK drawing A-52587.
4. Vee Orifice option is shown on drawing with phantom lines.
5. Install the valve with the higher pressure against the side opposite the seat when the valve is closed.

Accessories

Positioners

DeZURIK cylinder actuators are available with pneumatic or electro-pneumatic or digital positioners for throttling control. Positioners are enclosed and mounted on the yoke.

Air Filter Regulator

The DeZURIK Air Filter Regulator is designed to provide clean, accurate air pressure to actuators and positioners.

Manual Loading Station Control Panel

For all positioning pneumatic actuators. Output is 0–15 psi (0–100 kPa). It includes signal output gauge and pressure reducing valve. Order as a separate item by giving code ACC*CNP025.

Four-Way Manual Control Valves

Four-Way Manual Control Valves are for all pneumatic or hydraulic double-acting cylinder actuators. They are available mounted or as a separate item. To order mounted as part of a complete valve and actuator assembly, add code from table below to valve and actuator order code. To order separately, enter code ACC* followed by code from table below.

Valve Size	NPT Size (Inches)	Code
2–36" (50–900mm)	1/4"	CV201
2–10" (50–250mm)	3/8"	CV202
12–36" (300–900mm)	1/2"	CV203

Ordering Example: KGC,4,GV,S1,SMP,S1-M*CY-PC6,CV201

Ordering Example (Separate Item): ACC*CV201

Four-Way Solenoid Valves

Solenoid valves may be ordered mounted and piped as part of a complete valve/actuator assembly or as a separate item.

Speed Control Valves

Speed Control Valves are available for controlling valve opening or closing speed with pneumatic actuators. The speed of operation is adjustable. To order mounted, add the appropriate code to the valve and actuator order code.

Speed Control	Order Code
Two speed controls	SP
One control to close	SPC
One control to open	SPO

Ordering Example:

KGC,4,GV,F1,S1,SMP,S1-M*CY-PC6,SP

Position Indicating Switches

Position Indicating Switches are available for use on double-acting cylinder actuators. Order as part of a complete valve/actuator assembly by adding the appropriate code from the table below to the valve and actuator order code. Two switches will automatically be set to indicate full open and full closed positions.

Two Switches — Open/Closed

Description	Switch Type	Rating	Order Code
2 SPDT	Mechanical	Nema 1,3,4,6,13	SE649
2 DPDT	Mechanical	Nema 1,3,4,6,13	SE524
2 SPDT	Mechanical	Nema 1,3,4,6,7,9,13	SEH95
2 DPDT	Mechanical	Nema 1,3,4,6,7,9,13	SEH96
2 SPDT, Brass Housing	Proximity	No Approval	SEH93
2 SPDT, SST Housing	Proximity	UL, CSA, FA*	SEH94

*Class I, Div. 1, Group A,B,C,D, Class II, Groups E,FG

One Switch — Open

Description	Switch Type	Rating	Order Code
1 SPDT	Mechanical	Nema 1,3,4,6,13	SEJ40
1 DPDT	Mechanical	Nema 1,3,4,6,13	SEJ42
1 SPDT	Mechanical	Nema 1,3,4,6,7,9,13	SEJ46
1 DPDT	Mechanical	Nema 1,3,4,6,7,9,13	SEJ44
1 SPDT, Brass Housing	Proximity	No Approval	SEJ36
1 SPDT, SST Housing	Proximity	UL, CSA, FA*	SEJ38

One Switch — Closed

Description	Switch Type	Rating	Order Code
1 SPDT	Mechanical	Nema 1,3,4,6,13	SEJ41
1 DPDT	Mechanical	Nema 1,3,4,6,13	SEJ43
1 SPDT	Mechanical	Nema 1,3,4,6,7,9,13	SEJ47
1 DPDT	Mechanical	Nema 1,3,4,6,7,9,13	SEJ45
1 SPDT, Brass Housing	Proximity	No Approval	SEJ37
1 SPDT, SST Housing	Proximity	UL, CSA, FA*	SEJ39

Ordering Example:

KGC,4,GV,F1,S1,SMP,S1-M*CY-PC6,SEH96

Sales and Service

For information about our worldwide locations, approvals, certifications and local representative:

Web Site: www.dezurik.com E-Mail: info@dezurik.com



250 Riverside Ave. N. Sartell, Minnesota 56377 • Phone: 320-259-2000 • Fax: 320-259-2227

DeZURIK reserves the right to incorporate our latest design and material changes without notice or obligation. Design features, materials of construction and dimensional data, as described in this bulletin, are provided for your information only and should not be relied upon unless confirmed in writing by DeZURIK. Certified drawings are available upon request.