

## JCM Fabricated Expansion Joints

JCM Expansion Joints permit up to 10" of concentrated pipe movement that provides for normal expansion/contraction of pipelines subject to variations of both environmental and line content temperatures. JCM Expansion Joints are manufactured using a telescoping design that consists of a fabricated steel body, or housing, that accommodates an inserted internal "slip pipe" that moves in and out of the body. This free movement absorbs the linear, or axial, movement of the section of pipe. The fabricated steel body houses a "packing" area of alternating rings of lubricated flax and rubber that provides the water tight seal during the cycling of the joint. JCM Expansion Joints offer several design options including end connections, coatings, limit rods, stainless steel fabrication and others. JCM Expansion Joints are manufactured for each specific application allowing for the incorporation of special options or engineered features required for the installation.

**Heavy Duty Construction** - The heavy duty, durable exterior body provides the protective shell for the slip pipe and packing system. For corrosive or acidic environments, the expansion joint may be epoxy coated or fabricated of stainless steel.

**Externally Guided Slip Pipe** - The chromed slip pipe furnishes a hard, corrosion resistant surface that reduces friction between the slip pipe and packing material. For corrosive environments or line contents, slip pipe is available fabricated of stainless steel.

**Adjustable Packing Gland** - Alternating rings of lubricated flax and rubber are packed tightly into the packing area of the body by the adjustable packing gland. This packing gland maintains a consistent compression of the flax/rubber rings to ensure a tight, leak proof seal between the slip pipe and body.

**Lubricated Packing** - The rings of lubricated flax provide the "lubrication" to the slip pipe ensuring a smooth expanding/contracting movement while the square rubber rings secure the water tight seal. This packing area is easily accessible, without disruption of service, should repacking be required.



### HOW TO ORDER

For pricing and engineering, the following information must be furnished:  
JCM 801 and 802 are available fabricated of 304 stainless steel or 316 stainless steel

Type of pipe  
Outside diameter of pipe  
Type of End Connections  
Line Contents  
Minimum and maximum temperatures  
Maximum working pressure  
Material and Coating specifications

**JCM 802 Double End Expansion Joints** are designed for special applications such as middle of line use where expansion joint body can be anchored. This fitting permits up to 10" total pipe movement, 5" on each end, with properly anchored body.

## JCM Fabricated Expansion Joints

JCM Expansion Joints are available as Model 801 Single End design or Model 802 Double End Expansion Joint and are available with the following options:

- (1) Weld-On Ends without Limit Rods
  - (2) Weld-On Ends with Limit Rods
  - (3) Flanged Ends without Limit Rods
  - (4) Flanged Ends with Limit Rods
  - (5) Mechanical Joint Ends without Limit Rods
  - (6) Mechanical Joint Ends with Limit Rods
- Other end connections available  
Increased or decreased amounts of pipe movement capability

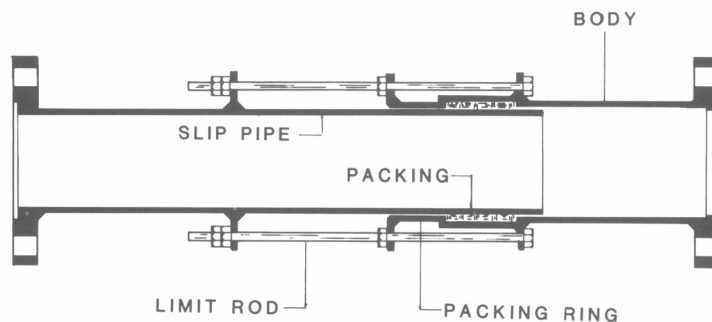

JCM 801 Single End Expansion Joint

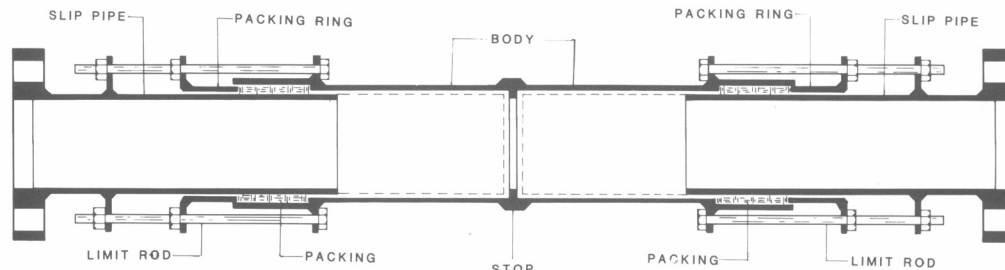

JCM 802 Double End Expansion Joint

### JCM Expansion Joint - Typical Specifications

Expansion Joints shall be of the externally guided, slip joint type, permitting up to 10" of concentrated pipe movement. The packing gland shall have alternate rings of lubricated flax and rubber specially compounded for use with water, salt solutions, mild acids, bases, natural gas and sewage. The body of the expansion joint shall have a shop coat primer. The slip pipe shall be machined and be chrome plated. Expansion Joint shall be ANSI/NSF Standard 61 Certified. Expansion Joints shall be JCM 801 or approved equal.

### JCM Expansion Joint - Material Specifications

<b>BODY MATERIAL:</b>	ASTM A-36 Carbon Steel. Optional 304 or 316 Stainless Steel
<b>SLIP PIPE:</b>	ASTM A53B Machined, chrome plated. Optional 304 or 316 Stainless Steel.
<b>GASKET AND FLAX:</b>	Square packing Buna-N rubber, 55 - 60 durometer, compounded for use with water, salt solutions, mild acids, bases and sewage. Flax: Gurlock waxed, braided cord (hemp).
<b>LIMIT RODS:</b>	Grade B-5
<b>FINISH:</b>	Heavy coat of corrosion resistant primer.