

JCM 301 Flanged Coupling Adapters

The Quick, Simple, Economical way to join flanged fittings, valves and meters to plain end pipe.

Ductile Iron body and flange and corrosion resistant high strength alloy bolts provide high strength and corrosion resistance to installations.

Laying length provides extra margin of safety for field cutting of pipe, yet is short enough for close quarter installations.

Full bolting to compression flange provides proper gasket compression. Many adapters use half the number of the standard flange.

Special flange gasket provides extra sealing capability on new and old flanged fittings and equipment. The wide molded gasket has a special lip which increases its sealing pressure with increases in line pressure.

Special flange design provides extra versatility which makes it an excellent means for installing wafer type valves, fittings and equipment.

Optional retainer set screws anchor the adapter on steel, cast iron and ductile iron pipe eliminating the need for tie rods, thrust blocks and additional joint restraint. Retainer set screws are not exposed to the line contents and do not require drilling of pipe.

Special wide range gaskets, which are interchangeable with JCM Ductile Iron Couplings, provide extra field versatility necessary on installations involving deflection, oversize pipe, out-of-round and uneven pipe ends.

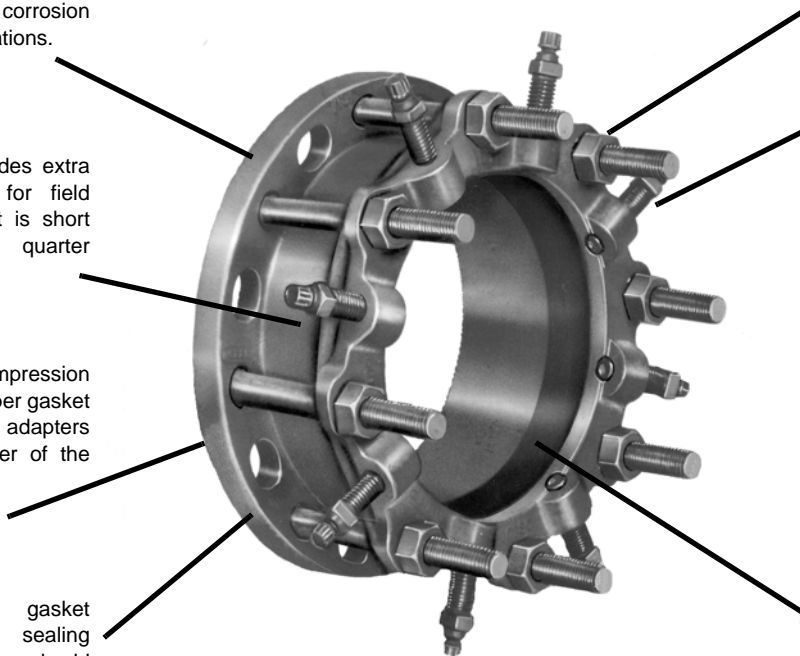

JCM 301 Flanged Coupling Adapter Dimensions

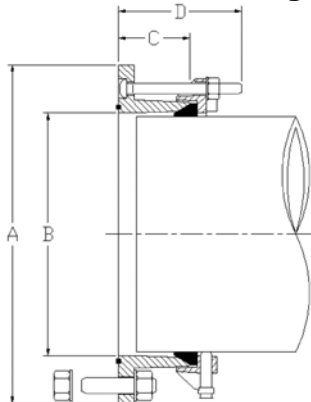

Nominal Size	A	B	C	D
3	8-1/8	5-1/4	3	5
4	9-1/8	5-1/4	3	5
6	11-1/8	7-5/16	3-1/2	5
8	13-1/2	9-9/16	3-1/2	5
10	16-1/4	11-9/16	4	6-1/2
12	19	13-5/8	4	6-1/2

The JCM 301 Flanged Coupling Adapter combines a flange with a ductile iron flexible coupling to provide a compact adapter fitting to connect plain end pipe to flanged fittings, meters, valves and equipment. The JCM 301 can be used to make on-site flanged spools and, when used with the optional set screws, eliminates the need for extra tie rods or harnessing assemblies on flanged equipment.

JCM 301 Flanged Coupling Adapters



301 Standard Flanged Coupling Adapter

301 Standard Flexible Flanged Coupling Adapter

The JCM 301 FCA provides a quick simple means of joining flanged fittings to plain end pipe. The 301 will absorb vibration, accommodate pipe deflection and expansion, provide for easy equipment removal and reinstallation, and eliminate the need for exact measurements.

301 Optional Restrained Flanged Adapter

Applications especially advantageous for using JCM FCA's

- Valve insertions
- Equipment connections and offset adjustment
- Converting flanged fittings to mechanical joint or push on type
- Dampening vibration
- Providing for field fitting of flanged spool pieces

301 FLANGED COUPLING ADAPTERS

NOM. PIPE SIZE (IN.)	PIPE O.D. RANGE (IN.)	CATALOG NUMBER	QTY OPTIONAL SET SCREWS	APPR. WT EACH (LBS.)
3	3.50	301-0350	4	17
	3.80 - 4.17	301-0396	4	17
4	4.00	301-0400	N/A	22
	4.50	301-0450	4	22
	4.80 - 5.10	301-0480	4	22
6	6.00	301-0600	N/A	37
	6.63	301-0663	8	37
	6.90 - 7.20	301-0690	8	37
8	8.00	301-0800	N/A	44
	8.63	301-0863	8	44
	9.05 - 9.40	301-0905	8	44
10	10.75	301-1075	12	67
	11.10 - 11.40	301-1110	12	67
12	12.75	301-1275	12	94
	13.20 - 13.50	301-1320	12	94

*Set Screws are not for use on Asbestos Cement, HDPE or PVC pipe.

Add (R) to end of Catalog Number to indicate optional set screws.

Note: Applications in which pipe may move out of the coupling, proper anchorage of the pipe must be provided.

MATERIAL SPECIFICATIONS - JCM 301 FLANGED COUPLING ADAPTER

BODY & FLANGE: Ductile Iron ASTM A536

GASKET: Specially compounded new rubber polymer for superior shelf life and resistance to permanent set. Recommended for water, salt solutions, mild acids & bases.

BOLTS: High strength, low alloy AWWA C-111, ANSI A21.11.

FINISH: Heavy coating of corrosion resistant shop coat primer. Optional Fusion Epoxy Coating Available

JCM Industries flanged adapters meet or exceed the ANSI/AWWA C-219 Standard as applicable.

