

JCM 116 Repair Sleeve for Concrete Steel Cylinder Pipe

The JCM 116 Repair Sleeve for Concrete Steel Cylinder Pipe provides a quick easy means of repairing and reinforcing damaged concrete steel cylinder pipe of all sizes. This repair sleeve permits repairs to be made on any side of the pipe - without requiring complete stripping of the concrete. The standard repair gasket seals around a 12" damaged area. Larger repair sizes are available. This sleeve is especially recommended for larger sizes of pipe and where the concrete and pipe require reinforcement.

Minimal Pipe Excavation - JCM 116 Repair Sleeve requires limited pipe exposure around the damaged area. Full section joint exposure is eliminated.

Wide Supportive Body - reinforces pipe which is weakened due to structural interruption. The body's grout seal assembly provides a system for replacement of the critical corrosion retarding concrete encasement. By restoring the concrete casing, the steel cylinder is protected from corrosive elements.

Eliminates Excessive Concrete Coating Removal - concrete removal is limited to the damaged area only, preventing further pipe structural damage

Epoxy Coated Repair Plate - the internal repair plate is fusion epoxy coated to provide a quality repair protected against corrosion in the pipe interior.

Eliminates Welding On Thin Cylinders - JCM 116 directly repairs the damaged cylinder making a watertight seal, preventing the line contents from infiltrating the concrete-steel interface.

Availability - The JCM 116 Repair Sleeve for Concrete Steel Cylinder Pipe is available from JCM on both an emergency and a contingency basis. Timely delivery and installation prevents extensive pipe damage, content loss and environmental violations.

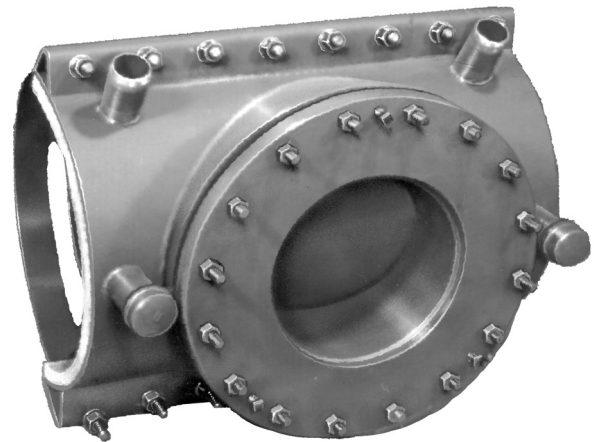

JCM 116 Repair Sleeve for Large Diameter Pipe

The JCM 116 Repair Sleeve is also recommended for repairs on large diameter pipe including cast iron, ductile iron, steel, and other types of large diameter rigid pipe. The direct concentration of bolting pressure to the repair gland area enables the 116 to repair the damaged area while maintaining the pipeline's pressure capability.

JCM 116 Repair Sleeve for Concrete Steel Cylinder Pipe

The JCM 116 Repair sleeve provides fast, economical and permanent repairs to Concrete Pressure Pipe. Sealing around the damaged area on the steel cylinder, the JCM 116 prevents the line contents from leaking between the concrete/steel cylinder interface, and eliminates further possible damage caused by corrosion. The adjustable, separate gland seals directly on the steel cylinder over the damaged area requiring removal of the mortar coating only in the repair area. Universal grouting horns are located to accommodate re-grouting of the damaged area at any position on the pipe.

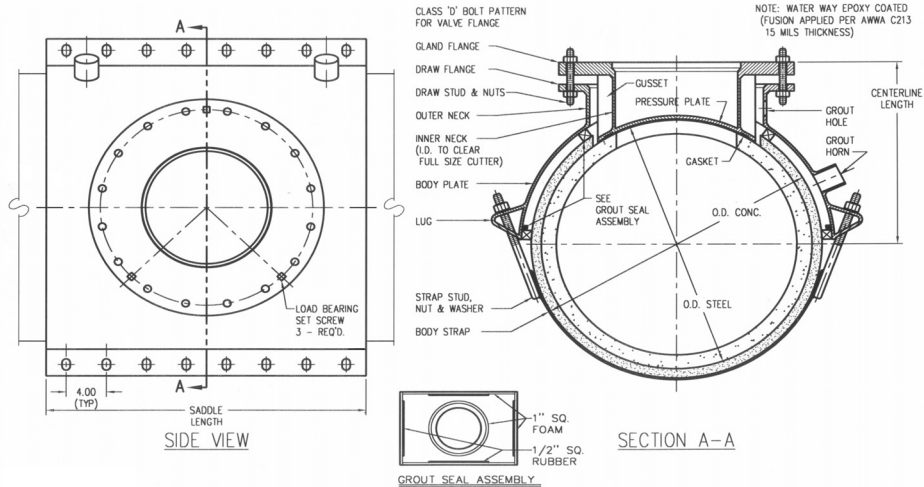

HOW TO ORDER

For pricing and engineering, the following information must be furnished:

- Type of pipe (also manufacturer and class if known)
- Diameter of damaged area
- Outside Diameter of Concrete and Cylinder
- Line Content and Pressure
- Any special requirements or options

JCM 116 Repair Sleeve for Concrete Pressure Pipe - Typical Specifications

JCM 116 Fabricated Repair Sleeves for Concrete Steel Cylinder Pipe shall be able to repair and reinforce damaged concrete steel cylinder pipe without requiring complete stripping of the concrete. The repair sleeves shall have a separate gland which permits installation and reinforcement of the pipe prior to the cutting of the prestress wires. The repair gland shall have a fusion epoxy coated pressure plate and a broad gasket set in a retaining groove of the pressure plate which is gusseted to eliminate flexing. Repair Sleeves shall be JCM 116 Repair Sleeves or approved equal. Repair Sleeves shall be ANSI/NSF Standard 61 Certified.

JCM 116 Repair Sleeve For Concrete Pressure Pipe - Material Specifications

- BODY:** ASTM 283 Grade C or ASTM A-36
- GASKET:** Compounded for use with water, salt solutions, mild acids, bases and sewage.
- BOLTS:** Corrosion resistant, high strength low alloy (AWWA C-111, ANSI 21.11) Optional Stainless Steel, 18-8 Type 304.
- COATING:** Heavy coat of corrosion resistant primer on sleeve, gland and straps. Pressure plate of gland is epoxy coated (fusion applied per AWWA C-213). Optional Fusion applied epoxy coating on entire sleeve.