

ITT

BGPGS

Wastewater

Goulds Pumps RGS Grinder Packages



TYPICAL GUIDE RAIL BASIN KIT



S10020 NEMA 4X OUTDOOR
CONTROL PANEL



TYPICAL SWITCH

FEATURES

Pump:

- Capacities: to 41 GPM, Total Heads: to 95' TDH
- Discharge: 1 1/4" NPT
- Temperature: 104° F continuous, 140° F intermittent.
- Single mechanical seal: silicon carbide rotary/silicon carbide stationary, 300 series stainless steel metal parts, BUNA-N elastomers.
- Rotating cutter and cutter ring: 440 C stainless steel, hardened to 55 – 60 Rockwell C.

Motor:

- Single phase: 2 HP, 60 Hz, 3450 RPM, 208/230V, capacitor start with on winding thermal protector.
- Class F insulation.
- Shaft: 300 series stainless steel threaded design.
- Bearings: ball bearings upper and lower.
- Power cord: 20 feet standard 14/3 STOW.
- See BRGS2012 pump bulletin for additional data.

AGENCY LISTINGS



Tested to UL 778 and CSA 22.2 108 Standards
By Canadian Standards Association
File #LR38549



Goulds Pumps is a brand of ITT Corporation.

www.goulds.com

Engineered for life

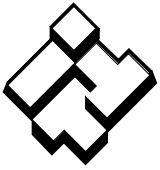

ITT

GOULDS PUMPS Wastewater

Pump/Control Kit	Order No.	Description
Simplex	SIMRGSKTN4*	(1) RGS2012 2HP, 230 V, single phase, pump
		(1) S10020 Simplex outdoor control panel
		(3) A2D23W Mechanical level switch
		4K639 Cast iron pump leg (set of 3)
Duplex	DUPRGSKTN4*	(2) RGS2012 2 HP, 230 V, single phase, pump
		(1) D10020 Duplex outdoor control panel
		(3) A2D23W Mechanical level switch
		4K639 Cast iron pump leg (set of 3)

* For indoor panel delete suffix "N4", SIMRGSKT includes a S10020N1 panel.
DUPGRSKT includes a D10020N1 panel.

Grinder Pump Packages

A complete simplex or duplex installation consists of a simplex or duplex pump kit AND a simplex or duplex basin kit.

Choose the simplex or duplex basin kit from the chart on the following pages to best suit your installation needs and make sure it is included in your order.

Both pump/control kit and basin kit must be ordered for a complete installation.

PUMP AND CONTROL DATA

Component	HP	Volts	Phase	RPM	Maximum Amps	LRA	Full Load Motor Efficiency	Resistance		Power Cable	Fuse/Circuit Breaker	Weight (lbs.)	
								Start	Line-Line				
RGS2012	2	208/230	1	3450	15	59	70	2.47	0.6	14/3	30	75	
S10020	Simplex Outdoor N4X Panel							20 Maximum Amps					
S10020N1	Simplex Indoor N1 Panel							20 Maximum Amps					
D10020	Duplex Outdoor N4X Panel							20 Maximum Amps					
D10020N1	Duplex Indoor N1 Panel							20 Maximum Amps					

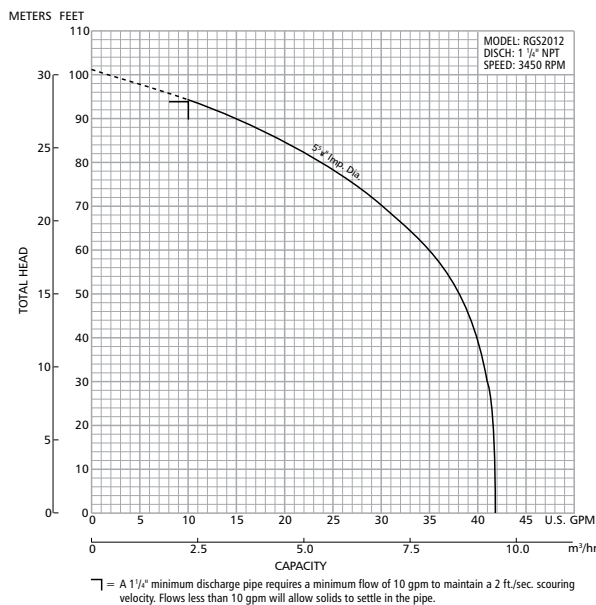

TYPICAL INSTALLATION

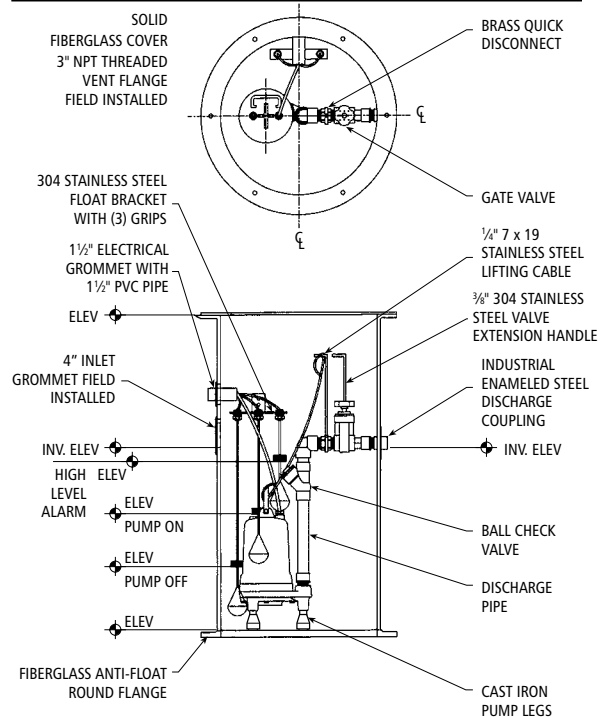

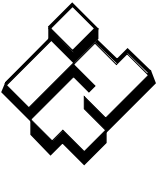

ITT

GOULDS PUMPS Wastewater

Basin Kits *(Each pump kit requires one of the following basin kits to complete the Residential Pump Package.)*

* Basins are not pre-drilled for 1.5" electrical grommet or for 4" inlet grommet. Parts are shipped loose. Installer must drill holes for grommets.

Guide Rail Equipped Basin Installation *(pump is suspended by its discharge)*

Simplex

- 24" diameter fiberglass basin with integral anti-floatation ring.
- Stainless steel hardware.
- Grass green solid fiberglass cover.
- 1.5" electrical grommet. *
- 4" inlet grommet. *
- Brass quick disconnect coupling.
- Schedule 40 galvanized steel discharge pipe.
- Cast iron ball type check valve.
- Bronze gate valve.
- 1/4" stainless steel pump lifting cable
- Pump slide rail system complete with PVC guide pipe and integral stainless steel guide bracket for those installations requiring a guide rail type system.

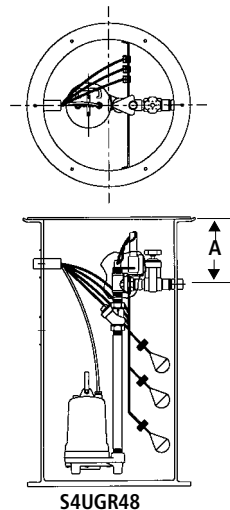

S4UGR48

Duplex

- 36" diameter fiberglass basin with integral anti-floatation ring.
- Stainless steel hardware.
- Grass green solid fiberglass cover.
- 1.5" electrical grommet. *
- 4" inlet grommet. *
- (2) Brass quick disconnect couplings.
- Schedule 40 galvanized steel discharge pipes.
- (2) Cast iron ball type check valves.
- (2) Bronze gate valves.
- (2) 1/4" stainless steel pump lifting cables.
- Pump slide rail system complete with dual pipe stainless steel guide rail system assembly for those installations requiring a guide rail type system.

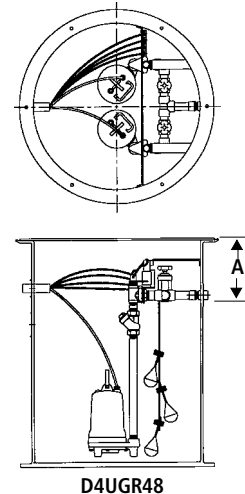

D4UGR48

Kit No.	Discharge Piping (SS)	Slide Rail	Basin Dia.	Basin Depth	"A" Dim.
S4UGR48	1.25"	Stainless steel guide bracket and PVC guide pipe	24"	48" (tall)	20"
S4UGR84	1.25"		24"	84" (tall)	42"

Kit No.	Discharge Piping (SS)	Slide Rail	Basin Dia.	Basin Depth	"A" Dim.
D4UGR48	1.25"	Stainless steel guide bracket and PVC guide pipe	36"	48" (tall)	20"
D4UGR84	1.25"		36"	84" (tall)	42"

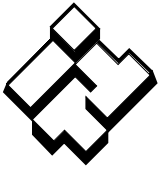

ITT

Wastewater

Basin Kits *(Each pump kit requires one of the following basin kits to complete the Residential Pump Package.)*

* Basins are not pre-drilled for 1.5" electrical grommet or for 4" inlet grommet. Parts are shipped loose. Installer must drill holes for grommets.

Non-Guide Rail Equipped Basin Installation *(pump stands on its own feet)*

Simplex

- 24" diameter fiberglass basin with integral anti-floatation ring.
- Stainless steel hardware.
- Grass green solid fiberglass cover.
- 1.5" electrical grommet. *
- 4" inlet grommet. *
- Brass quick disconnect coupling with stainless steel pull rod.
- Schedule 80 PVC discharge pipe.
- PVC ball type check valve.
- PVC gate valve.
- 1/4" stainless steel pump lifting cable.

Duplex

- 36" diameter fiberglass basin with integral anti-floatation ring.
- Stainless steel hardware.
- Grass green solid fiberglass cover.
- 1.5" electrical grommet. *
- 4" inlet grommet. *
- (2) brass quick disconnect couplings with stainless steel pull rods.
- Schedule 80 PVC discharge pipes.
- (2) PVC ball type check valves.
- (2) PVC gate valves.
- 1/4" stainless steel pump lifting cable.

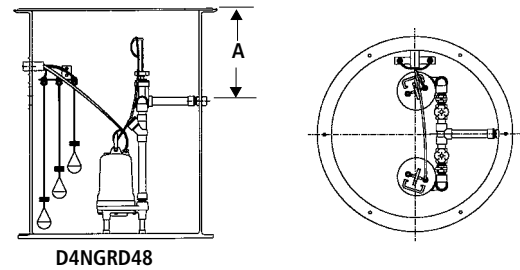
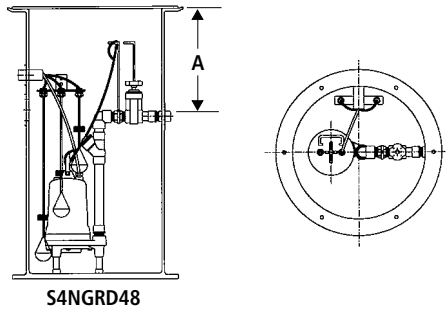

Kit No.	Discharge Piping (PVC)	Basin Diam.	Basin Depth	"A" Dim.
S4NGRD48	1.25"	24"	48" (tall)	20"
S4NGRD84	1.25"	24"	84" (tall)	42"
S2NGRD48	2.00"	24"	48" (tall)	20"
S2NGRD84	2.00"	24"	84" (tall)	42"

Kit No.	Discharge Piping (PVC)	Basin Diam.	Basin Depth	"A" Dim.
D4NGRD48	1.25"	36"	48" (tall)	20"
D4NGRD84	1.25"	36"	84" (tall)	42"
D2NGRD48	2.00"	36"	48" (tall)	20"
D2NGRD84	2.00"	36"	84" (tall)	42"



Goolds Pumps and the ITT Engineered Blocks Symbol are registered trademarks and tradenames of ITT Corporation.

SPECIFICATIONS ARE SUBJECT TO CHANGE WITHOUT NOTICE.

BGPGS May, 2008

© 2008 ITT Corporation

Engineered for life