

**SARTELL**  Valves &  
Controls

# **GKU UNIDIRECTIONAL KNIFE GATE VALVES TECHNICAL SPECIFICATIONS**

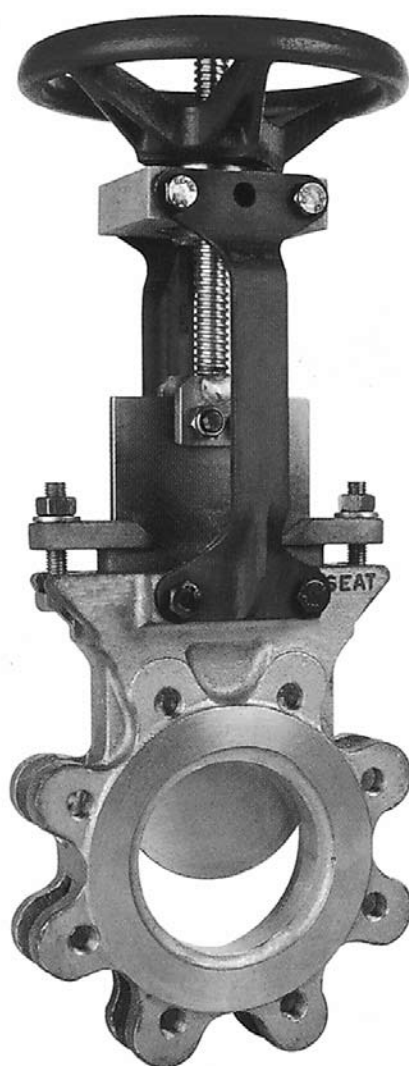

## Design & Construction

Sartell Valves & Controls Stainless Steel Knife Gate Valves are designed for on-off and throttling applications. They feature a cast, corrosion resistant body in 304 or 316 stainless steel and a 304 or 316 stainless steel gate.

Stainless Steel Knife Gate Valves are available in sizes 2"-48" (50mm-1200mm) and in metal and resilient seated versions.

A variety of actuator options are available including handwheels, chainwheels, bevel gears, cylinder and electric motors. A full complement of accessories is also offered.

**Stainless Steel Stem**—All valves are furnished with a stainless steel stem that assures easy operation and dependable service.

**One Piece Cast, Corrosion Resistant Body**—The heavy duty, cast stainless steel body provides corrosion and abrasion resistance on the toughest liquid, slurry and dry material handling applications. The all stainless steel body, chest, and packing chamber provide durability and integrity for all wetted parts.

**Rugged Gate Guides and Jams**—Gate guides provide support for the moving gate. Gate jams at the bottom of the body hold the gate securely against the seat to assure positive shutoff.

**Integral Lug Body**—Raised face body has drilled and tapped lugs in accordance with ANSI 125/150 lb. dimensions.

**Long Life Packing**—A variety of packing materials are offered to assure a tight seal with minimum packing gland pressure. Standard packing is PTFE impregnated syntex with maximum temperature to 450°F (232°C).

**High Flow Capacity**—Full, round port design allows high flow capacity and minimum pressure drop.

**Rugged Stainless Steel Gate**—Gates are available in 304 or 316 stainless steel for corrosion resistance. They feature a precision ground finish on both sides to prevent packing and seat damage. The beveled knife edge pushes aside or cuts through solids in the flow stream.

**Seat Options**—Metal and resilient seated.

**Resilient Seated Valves**—Resilient seated valves are available for applications where driptight shutoff is required. Unlike valves which use an o-ring seal, Sartell Valves & Controls Knife Gates have a resilient seat designed especially for knife gate valve applications. The resilient seat material is bonded into a stainless steel seat ring. When the valve is closed, the gate is pushed against the seat and held in place by the gate jams. When the valve is open, the gate moves away from the seat allowing operating clearance which prevents seat damage and makes operation easy.

Standard Resilient seat materials are chloroprene (CR) and acrylonitrile butadiene (NBR). The following options are available on applications: fluoro rubber (FKM), terpolymer of Ethylene, propylene and a diene (EPDM).

**Accessories**—A variety of accessories are offered as standard. Included are handwheel extensions, floor-stands, plus a variety of cylinder actuator accessories for customizing the valve/actuator package to meet your specific application requirements.

## Applicable Standards

**Sartell Valves & Controls GKU Knife Gate Valves are designed and/or tested to meet the following standards:**

MSS SP-81— Metal Seated Valves	Stainless Steel, Bonnetless, Flanged Knife Gate Valves.
ANSI B16.5 — 2–24" (50–600mm)	Carbon Steel Flanges and Flanged Fittings, ANSI 150. Conforms to related drilling dimensions.
ANSI 16.47 — 30–48" (750–1200mm)	Large diameter Steel Flanges. Series A. Conforms to related dimensions.
International Standards	Conforms to flanged bolt guides and pressure ratings — JIS 10; DIN 10 and DIN 16; ISO 7005-1/PN10 and 7005-1/PN16; BS 4504/PN10 and BS 4504/PN16; and AS 2129 Tables D and E.

# Valve Selection

## Valve Flow Capacity (Cv/Kv)

Valve Size	Cv/Kv Round Port	Cv/Kv V-Orifice
2" 50mm	240/207	89/77
3" 80mm	565/486	210/181
4" 100mm	1040/895	386/332
5" 125mm	1670/1438	610/525
6" 150mm	2240/1929	900/775
8" 200mm	4460/3840	1660/1429
10" 250mm	6250/5381	2320/1998
12" 300mm	9400/8093	3490/3005
14" 350mm	12500/10763	4650/4004
16" 400mm	16500/14207	6110/5261
18" 450mm	21400/18425	8000/6888
20" 500mm	27000/23247	10101/8697
24" 600mm	39700/34182	15100/13001

Inches  
Millimeters

## Ordering

To order, simply complete the valve order code from information shown. An ordering example is shown for your reference.

### Valve Style

Give valve style code as follows:

GPU = Unidirectional Knife Gate Valves

### Valve Size

Give valve size code as follows:

2 = 2" (50mm)	14 = 14" (350mm)
3 = 3" (80mm)	16 = 16" (400mm)
4 = 4" (100mm)	18 = 18" (450mm)
6 = 6" (150mm)	20 = 20" (500mm)
8 = 8" (200mm)	24 = 24" (600mm)
10 = 10" (250mm)	30" - 48" On application
12 = 12" (300mm)	

### End Connections

Give end connection code as follows:

L1 = Lugged, ANSI 150  
L1T = Lugged ANSI 150, through bolting flange

#### Special Drilling (On Application)

L110 = Lugged, ISO 7005-1, DIN 10 or BS4504/10  
L116 = Lugged, ISO 7005-1, DIN 16 or BS4504/16

NOTE: For lugged through bolting with other drillings, consult Sartell Valves & Controls.

### Body Material

Give body material code as follows:

S1 = 304 Stainless Steel  
S2 = 316 Stainless Steel

# General Specifications

Valve Size: 2"-48" (50mm-1200mm)

Body Style: Lugged, ANSI 150

Shutoff: Resilient seated, drip tight.

## Materials of Construction

Description	Material
Body	304 Stainless Steel ASTM A351 CF8
	316 Stainless Steel ASTM A351 CF8M
Gate	304 Stainless Steel ASTM A351 A240
	316 Stainless Steel ASTM A351 A240
Packing	PTFE Impregnated Syntex Fiber to 450°F (232°C)
Gland	Ductile Iron ASTM A536 Grade 65-45-12, Epoxy Coated
Nut	Carbon Steel Zinc Plated
Screw	Carbon Steel Zinc Plated
Washer	Carbon Steel Zinc Plated
Removable Seat	Chloroprene to 180°F (82°C) CR
	Acrylonitrile Butadiene to 180°F (82°C) NBR

### Packing Material

Give packing material code as follows:

NOTE: The limiting factor in valve selection is the lowest temperature limit of the packing or seat.

#### Standard Packing:

STFE = PTFE Impregnated syntex with maximum Temperature -20 TO 450°F (-29 TO 232°C)  
Maximum Pressure 150psi

### Gate Material

Give gate material code as follows:

S1 = 304 Stainless Steel (Used with S1 body material only)  
S2 = 316 Stainless Steel (Used with S2 body material only)

### Seat Material

Give seat material code as follows:

NOTE: The limiting factor in valve selection is the lowest temperature limit of the packing or seat.

#### Standard Seats:

M = Metal Seated, to 1000°F (537°C) on 2 - 36" valves.  
-20 to 180°F (-29 to 83°C) on 42 - 48" valves  
CR = Chloroprene (RS16) -20 to 180°F (-29 to 83°C)  
NBR = Acrylonitrile-Butadiene (RS26) -20 to 180°F (-29 to 83°C)

#### Special Seats (On Application)

FKM = Fluoro Rubber (RS48) -20 to 400°F (-29 to 204°C)  
EPDM = Terpolymer of Ethylene, Propylene and a Diene (RS66) -20 to 250°F (-29 to 122°C)

### Options

Give options code as follows:

NOTE: CWP is required for all valves 30" & larger only

CWP3 = Cold Working Pressure 50psi (3 Bar)  
CWP5 = Cold Working Pressure 75psi (5 Bar)  
CWP7 = Cold Working Pressure 100psi (7.5 Bar)  
CWP10 = Cold Working Pressure 150psi (10 Bar)

### Ordering Example:

GPU,4,L1,S2,STFE,S2-CR\*MN-HD8

# Manual Actuators

## Handwheel and Chainwheel Actuators

All 2"–24" (50–600mm) valves can be furnished with handwheel actuators and chainwheel actuators. Bevel gear actuators are available on

14"–48" (350–1200mm) valves with handwheel or chainwheel actuators. To order handwheel or chainwheel actuators, add the appropriate order code to the basic valve order code.

### Actuator Sizing Handwheel Actuator

Valve Size	Order Code	Max. Pressure Differential psi/kPa
2" 50mm	MN-HD8	150 1030
3" 80mm	MN-HD8	150 1030
4" 100mm	MN-HD8	150 1030
6" 150mm	MN-HD10	150 1030
8" 200mm	MN-HD12	150 1030
10" 250mm	MN-HD16	150 1030
12" 300mm	MN-HD16	150 1030
14" 350mm	MN-HD20	125* 860*
16" 400mm	MN-HD20	100* 690*
18" 450mm	MN-HD20	75* 520*
20" 500mm	MN-HD20	50* 340*
24" 600mm	MN-HD20	25* 170*

\*Bevel gear actuators are recommended when pressure exceeds limits shown.

#### Ordering Example:

GPU,6,L1,S1,STFE,S1-CR\*MN-HD10

### Chainwheel Actuator

Valve Size	Order Code	Max. Pressure Differential psi/kPa
2" 50mm	MN-CW12	150 1030
3" 80mm	MN-CW12	150 1030
4" 100mm	MN-CW12	150 1030
6" 150mm	MN-CW12	150 1030
8" 200mm	MN-CW12	150 1030
10" 250mm	MN-CW16	150 1030
12" 300mm	MN-CW16	150 1030
14" 350mm	MN-CW20	125* 860*
16" 400mm	MN-CW20	100* 690*
18" 450mm	MN-CW20	75* 520*
20" 500mm	MN-CW20	50* 340*
24" 600mm	MN-CW20	25* 170*

\*Bevel gear actuators are recommended when pressure exceeds limits shown.

#### Ordering Example:

GPU,6,L1,S1,STFE,S1-CR\*MN-CW12

## Bevel Gear Actuators

Bevel gear actuators provide vertical mounting of the handwheel or chainwheel when the valve is installed vertical, or can be used where space limitations prohibit the use of a standard handwheel or chainwheel. The mechanical advantage provided by a bevel gear makes large valve operation easier and faster.

### Actuator Mounting

Bevel gears can be mounted at standard, 90, 180 or 270 degree mounting. To order, use the appropriate order code from the chart for standard or 180 degree mounting, or 90 or 270 degree mounting. Specify which position as second line information.

#### Bevel Gear Handwheel Actuator

Valve Size	Cold Working Pressure	Order Code Std./180 Mounting	Order Code 90/270 Mounting	Maximum Shutoff Pressure Differential psi/kPa
14" (350mm)	N/A	MNB-102-HD20	MNB-102-HD20-A	150 / 1030
16" (400mm)	N/A	MNB-102-HD20	MNB-102-HD20-A	150 / 1030
18" (450mm)	N/A	MNB-143-HD20	MNB-143-HD20-A	150 / 1030
20" (500mm)	N/A	MNB-143-HD20	MNB-143-HD20-A	150 / 1030
24" (600mm)	N/A	MNB-143-HD20	MNB-143-HD20-A	150 / 1030
30" (750mm)	CWP 3	MNB-143-HD20	MNB-143-HD20-A	50 / 340
30" (750mm)	CWP5	MNB-143-HD20	MNB-143-HD20-A	75 / 515
30" (750mm)	CWP7	MNB-143-HD20	MNB-143-HD20-A	100 / 690
30" (750mm)	CWP10	MNB-145-HD20	MNB-145-HD20-A	150 / 1030
36" (900mm)	CWP3	MNB-143-HD20	MNB-143-HD20-A	50 / 340
36" (900mm)	CWP5	MNB-144-HD20	MNB-144-HD20-A	75 / 515
36" (900mm)	CWP7	MNB-145-HD20	MNB-145-HD20-A	100 / 690
36" (900mm)	CWP10	MNB-145-HD20	MNB-145-HD20-A	150 / 1030
42" (1100mm)	CWP3	MNB-144-HD20	MNB-144-HD20-A	50 / 340
42" (1100mm)	CWP5	MNB-144-HD20	MNB-144-HD20-A	75 / 515
42" (1100mm)	CWP7	MNB-145-HD20	MNB-145-HD20-A	100 / 690
48" (1200mm)	CWP3	MNB-145-HD20	MNB-145-HD20-A	50 / 340
48" (1200mm)	CWP5	MNB-145-HD20	MNB-145-HD20-A	75 / 515
48" (1200mm)	CWP7	MNB-145-HD20	MNB-145-HD20-A	100 / 690

#### Ordering Example:

GPU,18,L1,S1,STFW,  
S1-CR\*MNB-143-HD20-A

Actuator mounted 90 degree  
from standard.

## Bevel Gear Chainwheel Actuator

Valve Size	Cold Working Pressure	Order Code Std./180 Mounting	Order Code 90/270 Mounting	Maximum Shutoff Pressure Differential psi/kPa
14" (350mm)	N/A	MNB-102-CW12	MNB-102-CW12-A	150 / 1030
16" (400mm)	N/A	MNB-102-CW12	MNB-102-CW12-A	150 / 1030
18" (450mm)	N/A	MNB-143-CW20	MNB-143-CW20-A	150 / 1030
20" (500mm)	N/A	MNB-143-CW20	MNB-143-CW20-A	150 / 1030
24" (600mm)	N/A	MNB-143-CW20	MNB-143-CW20-A	150 / 1030
30" (750mm)	CWP3	MNB-143-CW20	MNB-143-CW20-A	50 / 340
30" (750mm)	CWP5	MNB-143-CW20	MNB-143-CW20-A	75 / 515
30" (750mm)	CWP7	MNB-143-CW20	MNB-143-CW20-A	100 / 690
30" (750mm)	CWP10	MNB-145-CW20	MNB-145-CW20-A	150 / 1030
36" (900mm)	CWP3	MNB-143-CW20	MNB-143-CW20-A	50 / 340
36" (900mm)	CWP5	MNB-144-CW20	MNB-144-CW20-A	75 / 515
36" (900mm)	CWP7	MNB-145-CW20	MNB-145-CW20-A	100 / 690
36" (900mm)	CWP10	MNB-145-CW20	MNB-145-CW20-A	150 / 1030
42" (1100mm)	CWP3	MNB-144-CW20	MNB-144-CW20-A	50 / 340
42" (1100mm)	CWP5	MNB-144-CW20	MNB-144-CW20-A	75 / 515
42" (1100mm)	CWP7	MNB-145-CW20	MNB-145-CW20-A	100 / 690
48" (1200mm)	CWP3	MNB-145-CW20	MNB-145-CW20-A	50 / 340
48" (1200mm)	CWP5	MNB-145-CW20	MNB-145-CW20-A	75 / 515
48" (1200mm)	CWP7	MNB-145-CW20	MNB-145-CW20-A	100 / 690

\*Contact Factory for Maximum Pressure Differential

### Ordering Example:

GKU,18,L1,S1,STFE,  
S1-CR\*MNB-143-CW20-A

Actuator mounted 90  
degree from standard.

## Accessories — Manual Actuators

### Chain

Chain for use with chainwheel actuators. Order as a separate item by giving code from table and specifying length of chain as second line information. Order as a separate item.

Chain Type	Order Code
Metric Zinc Plated Steel	ACC*CN107

### Ordering Example:

ACC\*CN107

Chain: 12 feet long (366cm)

### Deflection Cones

To prolong valve life in particularly demanding services, deflection cones are available in cast Ni-Hard, polyurethane and other materials. Order as a separate item by giving the correct code and valve size; used on metal seated valves only.

### Ordering Example:

ACC\*DC11NH-8

### Handwheel — 2" Nut Extension

Provides extension of the handwheel or nut to allow remote operation — normally from above. The extension includes fittings and extension pipe with handwheel or nut mounted. To order, specify description and extension length from center line of valve to top of handwheel or nut.

ENTS - EXTENDED 2" NUT (NON-RISING STEM)

ENHD - EXTENDED HANDWHEEL (NON-RISING STEM)

2" - 24" GKU Valves with MN-N or MN-HD\* Actuators

### Ordering Example:

GKU,4,L1,S2,STFE,S2-CR\*MN-N,ENTS

Centerline of valve to top of nut 72" (1829mm).

### Floorstand

A floorstand for handwheel actuated valves allows operation from above. Includes floorstand with gate position indicator, handwheel, fittings and extension. To order, specify length from center line of valve to base of floorstand. This dimension must be at least twice the dimension from center line to handwheel. For non-rising stems only. Rising stems on application.

## Electric Motor Actuators

Sartell Valves & Controls (GKU) Unidirectional Knife Gate Valves can be furnished with electric motor actuators, including Limitorque, Auma, Rotork, EIM, and others.

### Ordering

When ordering electric motor actuators, specify valve order code, shutoff pressure, service conditions — flowing media and installation direction; type of application — on/off or throttling; speed of operation; NEMA rating — 4, 7, submersible, etc.; electrical characteristics — voltage and phase; actuator accessories and controls as per specification requirements.

# Cylinder Actuators

## On-Off Cylinder Actuators

Sartell Valves & Controls cylinder actuators are available with double-acting pneumatic or hydraulic cylinders for on/off or throttling service. Supply pressure is 50 or 80 psi (340 or 550 kPa). To order, add the proper code from the on/off column of the table to the valve order code. Specify hydraulic media if other than oil.

## Throttling Cylinder Actuators

Sartell Valves & Controls cylinder actuators are available with pneumatic or electronic positioners for throttling control. Positioners are enclosed and mounted on the superstructure.

### Actuator Sizing

#### 50 psi (340 kPa) Air Supply

Valve Size	Actuator Order Code	Max. Pressure Differential psi/kPa	
		On/Off	
		Dry Solids, Slurries	Liquids & Gases
2" 50mm	CY-PC4	75 520	150 1030
3" 80mm	CY-PC4	75 520	150 1030
4" 100mm	CY-PC4	75 520	150 1030
6" 150mm	CY-PC4	~	150 1030
	CY-PC6	75 520	~
8" 200mm	CY-PC6	~	50 340
	CY-PC8	~	150 1030
10" 250mm	CY-PC6	~	50 340
	CY-PC8	~	150 1030
	CY-PC10	75 520	~
12" 300mm	CY-PC6	~	25 170
	CY-PC8	~	100 690
	CY-PC10	~	150 1030
	CY-PC12	75 520	~
14" 350mm	CY-PC6	~	25 170
	CY-PC8	~	50 340
	CY-PC10	~	100 690
	CY-PC12	75 520	150 1030
16" 400mm	CY-PC8	~	25 170
	CY-PC10	~	75 520
	CY-PC12	75 520	150 1030
18" 450mm	CY-PC8	~	25 170
	CY-PC10	~	50 340
	CY-PC12	75 520	150 1030
20" 500mm	CY-PC10	~	25 170
	CY-PC12	~	75 520
24" 600mm	CY-PC12	~	50 340
	CY-PC16	75 520	150 1030

Cylinder Actuators for larger valves on application.

#### 80 psi (520 kPa) Air Supply

Valve Size	Actuator Order Code	Max. Pressure Differential psi/kPa	
		On/Off	
		Dry Solids, Slurries	Liquids & Gases
2" 50mm	CY-PC4	75 520	150 1030
3" 80mm	CY-PC4	75 520	150 1030
4" 100mm	CY-PC4	75 520	150 1030
6" 150mm	CY-PC4	~	150 1030
	CY-PC6	75 520	~
8" 200mm	CY-PC6	~	75 520
	CY-PC8	75 520	150 1030
10" 250mm	CY-PC6	~	125 860
	CY-PC8	75 520	150 1030
12" 300mm	CY-PC6	~	75 520
	CY-PC8	75 520	150 1030
14" 350mm	CY-PC6	~	75 520
	CY-PC8	~	125 860
	CY-PC10	75 520	150 1030
16" 400mm	CY-PC6	~	50 340
	CY-PC8	~	100 690
	CY-PC10	75 520	150 1030
18" 450mm	CY-PC8	~	75 520
	CY-PC10	75 520	150 1030
20" 500mm	CY-PC8	~	50 340
	CY-PC10	~	125 860
	CY-PC12	75 520	150 1030
24" 600mm	CY-PC10	~	100 690
	CY-PC12	75 520	150 1030

Cylinder Actuators for larger valves on application.

# Basic Valve Dimensions

Valve Size	Dimensions				
	A	B	C	D	E
2" 50mm	1.89 48	8.00 203	12.20 310	13.18 335	18.30 465
3" 80mm	2.00 51	8.00 203	14.76 375	16.73 425	21.85 555
4" 100mm	2.00 51	8.00 203	16.53 420	19.48 495	24.40 620
5" 125mm	2.24 57	10.00 254	18.50 470	22.24 565	28.34 720
6" 150mm	2.24 57	10.00 254	20.07 510	24.60 625	30.70 780
8" 200mm	2.75 70	12.00 305	24.01 610	30.51 775	37.58 955
10" 250mm	2.75 70	15.98 406	26.18 665	36.02 915	43.70 1110
12" 300mm	3.00 76	15.98 406	29.72 755	41.53 1055	50.19 1275
14" 350mm	3.00 76	20.00 508	34.84 885	48.81 1240	56.29 1430
16" 400mm	3.50 89	20.00 508	35.43 900	51.18 1300	58.66 1490
18" 450mm	3.50 89	20.00 508	40.35 1025	58.46 1485	65.74 1670
20" 500mm	4.50 114	20.00 508	44.88 1140	64.56 1640	74.21 1885
24" 600mm	4.50 114	20.00 508	52.55 1335	76.37 1940	86.02 2185
30" & Larger	O/A	O/A	O/A	O/A	O/A

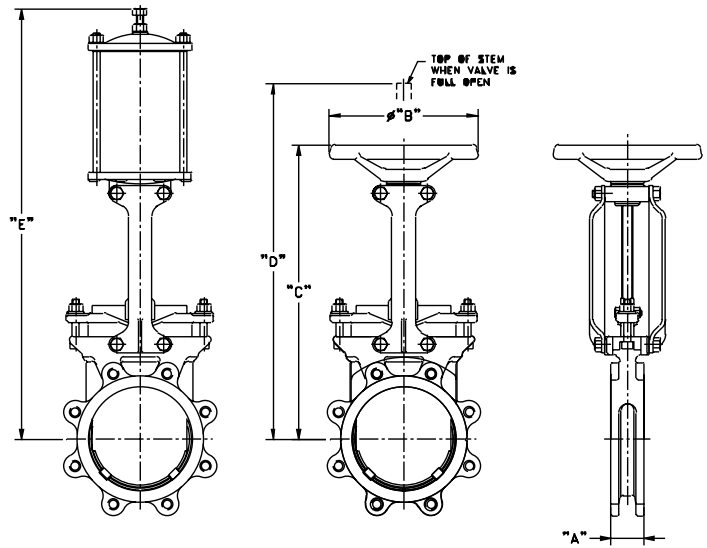

Inches  
Millimeters

**Note:** All dimensions are subject to change without notice.  
For piping layouts, request certified drawings.

# Valve Weights with Handwheel

Valve Size	2" 50mm	3" 80mm	4" 100mm	5" 125mm	6" 150mm	8" 200mm	10" 250mm	12" 300mm	14" 350mm	16" 400mm	18" 450mm	20" 500mm	24" 600mm	30" & Larger on applications	Inches Millimeters
Valve and Handwheel	20 9	29 13	35 16	46 21	53 24	79 36	137 62	183 83	220 100	313 142	386 175	628 285	794 360		Pounds Kilograms

# Accessories

## Air Filter Regulator

Sartell Valves & Controls Air Filter Regulator is designed to provide clean, accurate air pressure to actuators and positioners.

## Four-Way Manual Control Valves

Four-Way Manual Control Valves are for all pneumatic or hydraulic double-acting cylinder actuators. They are available mounted or as a separate item. To order mounted as part of a complete valve and actuator assembly, add code from table below to valve and actuator order code. To order separately, enter code ACC\* followed by code from table below.

Valve Size	Supply	NPT Size (Inches)	Code
2-36" (50-900mm)	Pneumatic	1/4"	CV201

### Ordering Example:

GKU,4,F1,S2,STFE,S2-CR\*CY-PC4,CV201

### Ordering Example (Separate Item):

ACC\*CV201

## Four-Way Solenoid Valves

Solenoid valves may be ordered mounted and piped as part of a complete valve/actuator assembly or as a separate item.

## Position Indicating Switches

Position Indicating Switches are available for use on double-acting cylinder actuators. Order as part of a complete valve/actuator assembly by adding the appropriate code from the table below to the valve and actuator order code. Two switches will automatically be set to indicate full open and full closed positions.

## Two Switches — Open/Closed

Description	Switch Type	Rating	Order Code
2 SPDT	Mechanical	Nema 1,3,4,6,13	SE649
2 DPDT	Mechanical	Nema 1,3,4,6,13	SE524
2 SPDT	Mechanical	Nema 1,3,4,6,7,9,13	SEH95
2 DPDT	Mechanical	Nema 1,3,4,6,7,9,13	SEH96
2 SPDT, Brass Housing	Proximity	No Approval	SEH93
2 SPDT, SST Housing	Proximity	UL, CSA, FA*	SEH94

\*Class I, Div. 1, Group A,B,C,D, Class II, Groups E,F,G

## One Switch — Open

Description	Switch Type	Rating	Order Code
1 SPDT	Mechanical	Nema 1,3,4,6,13	SEJ40
1 DPDT	Mechanical	Nema 1,3,4,6,13	SEJ42
1 SPDT	Mechanical	Nema 1,3,4,6,7,9,13	SEJ44
1 DPDT	Mechanical	Nema 1,3,4,6,7,9,13	SEJ46
1 SPDT, Brass Housing	Proximity	No Approval	SEJ36
1 SPDT, SST Housing	Proximity	UL, CSA, FA*	SEJ38

## One Switch — Closed

Description	Switch Type	Rating	Order Code
1 SPDT	Mechanical	Nema 1,3,4,6,13	SEJ41
1 DPDT	Mechanical	Nema 1,3,4,6,13	SEJ43
1 SPDT	Mechanical	Nema 1,3,4,6,7,9,13	SEJ45
1 DPDT	Mechanical	Nema 1,3,4,6,7,9,13	SEJ47
1 SPDT, Brass Housing	Proximity	No Approval	SEJ37
1 SPDT, SST Housing	Proximity	UL, CSA, FA*	SEJ39

### Ordering Example:

GKU,4,F1,S2,STFE,S2-CR\*CY-PC4,SE524

## Speed Control Valves

Speed Control Valves are available for controlling valve opening or closing speed with pneumatic actuators. The speed of operation is adjustable. To order mounted, add the appropriate code to the valve and actuator order code.

Speed Control	Order Code
Two speed controls	SP
One control to close	SPC
One control to open	SPO

### Ordering Example:

GKU,4,F1,S2,STFE,S2-CR\*CY-PC4,SP

## Sales and Service

For information about our worldwide locations, approvals, certifications and local representative:

Web Site: [www.sartellvalves.com](http://www.sartellvalves.com) E-Mail: [info@sartellvalves.com](mailto:info@sartellvalves.com)

# SARTELL Valves, Inc.



250 Riverside Ave. N. Sartell, Minnesota 56377 • Phone: 320-259-2000 • Fax: 320-259-2227

*Sartell Valves, Inc. reserves the right to incorporate our latest design and material changes without notice or obligation. Design features, materials of construction and dimensional data, as described in this bulletin, are provided for your information only and should not be relied upon unless confirmed in writing by Sartell Valves, Inc. Certified drawings are available upon request.*

Printed in the U.S.A.