

## Style 165 PLUS-TEMP™ Boltless Compression Couplings For Use on Steel Piping Systems

- Ideal for elevated temperature service up to 350° F
- Available in regular and long body couplings
- Sizes 3/4" IPS thru 2" IPS

Ideally suited for many OEM and industrial piping applications, Dresser® Style 165 PLUS-TEMP couplings and fittings provide dependable, easy to install products for elevated temperature service (up to 350°F) on air, water, fuel, lube, coolant, process and product lines. Also on such equipment as compressors and engines, hot water boilers, industrial furnaces and ovens, air conditioning and air handling installations, locomotives and stationary power systems.

The Style 165 eliminates the need for threading, grooving or exact pipe fitting while providing a permanently tight, flexible union which allows easy disassembly for cleaning or maintenance. Where pipe movement out of the coupling or fitting may be expected, proper anchorage of the pipe must be provided. Restraining rings can be incorporated into the product design to increase the pullout load where excessive pipe movement is expected. The 165 gasket selection guide (page 3) describes many of the line contents for which the Style 165's can be used. Dresser Style 165 PLUS-TEMP fittings provide the practical solutions to your high-temperature piping problems.

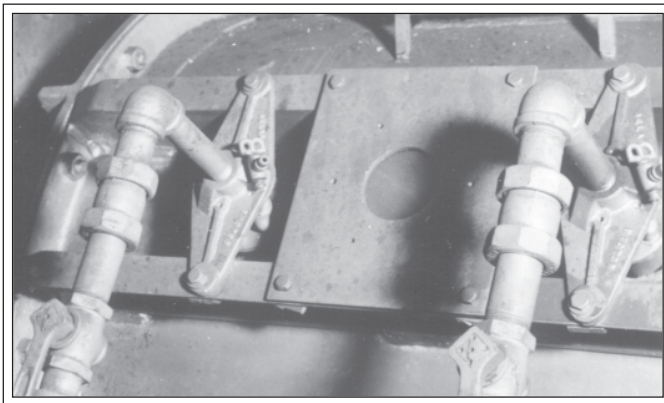

### Style 165 Coupling Components

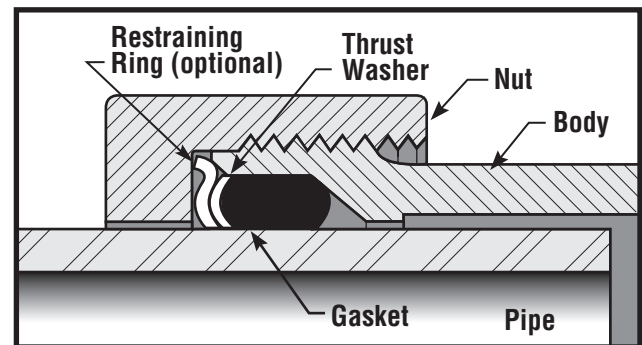

The cut-away drawing (left) shows the working principle of the Style 165 coupling after it has been tightened onto the pipe. The time-proven rubber compounded gasket seals against the pipe surface, forming a positive seal against leakage. The restraining ring shown is optional.

Style 165 couplings and fittings are well suited to elevated temperature applications such as industrial gas burners and heating systems.

# Style 165 PLUS-TEMP™ Compression Couplings

## Specifications for Sizes 3/4" thru 2"

Nominal Size Steel (In.)	Outside Diameter (O.D.) (In.)	PART NUMBER Dresser E-Coat (001)	Overall Dimensions			Dimension Drawings
			A	B	C	
<b>REGULAR COUPLINGS</b>						
3/4	1.050	0165-0003-001	1-27/32	2-21/32	2	
1	1.315	0165-0004-001	2-3/16	2-13/16	2-1/4	
1-1/4	1.660	0165-0005-001	2-5/8	3-1/4	2-1/2	
1-1/2	1.900	0165-0006-001	2-15/16	3-9/16	2-3/4	
2	2.375	0165-0007-001	3-19/32	3-7/8	3	
<b>LONG COUPLINGS</b>						
3/4	1.050	0165-0026-001	1-27/32	4-13/32	3-3/4	
1	1.315	0165-0027-001	2-3/16	4-11/16	4	
1-1/4	1.660	0165-0028-001	2-5/8	5	4-1/4	
1-1/2	1.900	0165-0029-001	2-15/16	5-3/16	4-1/2	
2	2.375	0165-0030-001	3-19/32	5-1/8	4-3/4	

**\*NOTE:** Couplings may be furnished with restraining rings for applications where excessive pipe movement may occur.

**All dimensions** are maximum, approximate and given in inches.

**Gaskets** included with all fittings are Dresser ARMORED™. A few services may require plain or special gaskets; priced on application.

**Dimension "A"** is measurement across the corner of octagonal end nut. The "across flats" dimension of nut is slightly less.

**Standard finish** is Dresser E-coat.

### Piping Specialties

41 Fisher Avenue, Bradford, PA 16701

Phone: (814) 362-9200

Fax: (814) 362-9344

Email: dmddsales@dresser.com



www.dresser.com