



Style 63 Expansion Joints



Dresser offers the broadest line of **Style 63 Expansion Joints** including single-end (Type 1 and Type 3 shown below), and double-end (Type 2 & 4), limited-movement types, flanged, lock coupled, or weld ends. Aggressive wear and pipe wall failure caused by fatigue of the convoluted surfaces present in rubber accordion or metal bellows types is eliminated with Dresser expansion joints. There is no need for expensive pipe loop systems.

Dresser expansion joints are built to order and are available up to 120" in diameter. Provided with rugged welded steel construction, Dresser expansion joints are also available in stainless or carbon steel, monel or other alloys for special applications. Single-end expansion joints permit up to 10" of concentrated pipe movement. Larger amounts of movement are available per application.

Special packing and lubrication requirements are custom-matched to specific fluid processes or application requirements. Temperature ratings to 800°F and pressure ratings to 1200 psi.

Available with Dresser AL-CLAD™ coating for optimum protection against aggressive water conditions and for handling brine, brackish water, coke oven gas, petroleum and other line content.

Style 63 Type 1 Sizes and Specifications

Pipe Nominal Size (In)	Outside Diameter (OD)	Bolts No./Diam. x Length (A&B)	Overall Dimensions		Weight Per Joint (Lbs)
			Diam. (C)	Length (D) (E)	
3	3.500	4-5/8 x 11	8-1/2	36 46	65
4	4.500	4-5/8 x 11	9-1/2	36 46	75
5	5.563	4-5/8 x 11	10-5/8	36 46	110
6	6.625	6-5/8 x 11	11-3/4	36 46	130
8	8.625	6-5/8 x 11	13-3/4	36 46	180
10	10.750	8-5/8 x 11	15-7/8	36 46	250
12	12.750	8-5/8 x 11	17-7/8	36 46	315
	14.000	8-5/8 x 11	19-1/2	36 46	340
	16.000	10-5/8 x 11	21-1/2	36 46	380
	18.000	10-5/8 x 11	23-1/2	36 46	415
	20.000	12-5/8 x 11	25-1/2	36 46	470
	22.000	14-5/8 x 11	27-1/2	36 46	525
	24.000	14-5/8 x 11	29-1/2	36 46	565

Style 63 Type 3 Sizes and Specifications

Pipe Nominal Size (In)	Outside Diameter (OD)	Bolts No./Diam. x Length (A&B)	Overall Dimensions		Weight Per Joint (Lbs)
			Diam. (C)	Length (D) (E)	
3	3.500	4-5/8 x 24	8-1/2	36 46	80
4	4.500	4-5/8 x 24	9-1/2	36 46	95
5	5.563	4-5/8 x 24	10-5/8	36 46	125
6	6.625	6-5/8 x 24	11-3/4	36 46	155
8	8.625	6-5/8 x 24	13-3/4	36 46	205
10	10.750	8-5/8 x 24	15-7/8	36 46	285
12	12.750	8-5/8 x 24	17-7/8	36 46	350
	14.000	8-5/8 x 24	19-1/2	36 46	385
	16.000	10-5/8 x 24	21-1/2	36 46	430
	18.000	10-5/8 x 24	23-1/2	36 46	470
	20.000	12-5/8 x 24	25-1/2	36 46	530
	22.000	14-5/8 x 24	27-1/2	36 46	590
	24.000	14-5/8 x 24	29-1/2	36 46	635

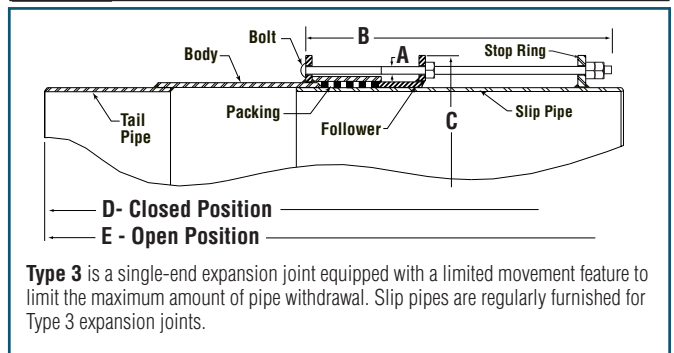
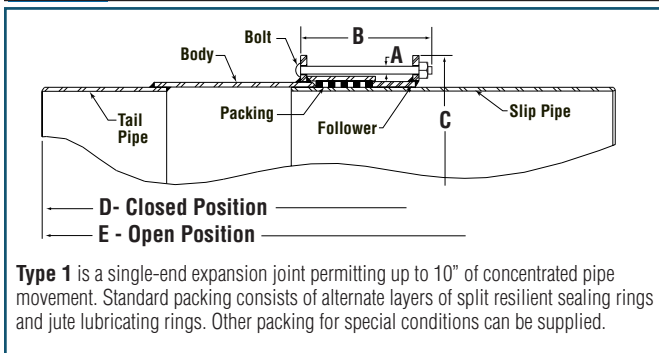

Dresser, Inc.
 41 Fisher Avenue
 Bradford, PA 16701
 Ph: (814) 362-9200
 Fax: (814) 362-9333
 Email: dmdsales@dresser.com

www.dressercouplings.com

Form No. 63/6-05
 REV. 6-06
 R1M