



Specifications

Sizes: 1/2" - 4"
Materials: PVC, PP, PVDF and PTFE
Model: Flanged (ANSI)
Stem Seal: PTFE Bellows
Valve Seal: FKM, EPDM, PTFE encapsulated FKM
Flow Char.: Linear or equal percentage
Rangeability: 1: 50 for 1/2" - 3", 1: 30 for 4"
Temp. Range: PVC 32- 140° F, PP -5 - 175° F
 PVDF -5 - 265° F, PTFE -5 - 284° F

Standard Features

- Precise flow control
- Solid thermoplastic valve body provides excellent corrosion resistance
- PTFE bellows stem seal eliminates old style packing glands and minimizes maintenance
- Positive bubble tight shut-off
- Plug and seat can be changed to accommodate a variety of valve coefficients (Cv)
- Plug (trim) can be characterized (linear or equal percentage) per requirements, See below
- No metal to media contact
- Extremely corrosion resistant actuator constructed of glass-filled Polyester (PEG) with SS trim
- Maximum required air pressure is 90 psi
- 3-15 psi direct acting for sizes up to 1"

Options

- 3-15 psi Pneumatic Positioner
- 4-20mA Electro-Pneumatic Positioner
- 4-20mA Output Transmitter
- Extra (Auxiliary) Limit Switches

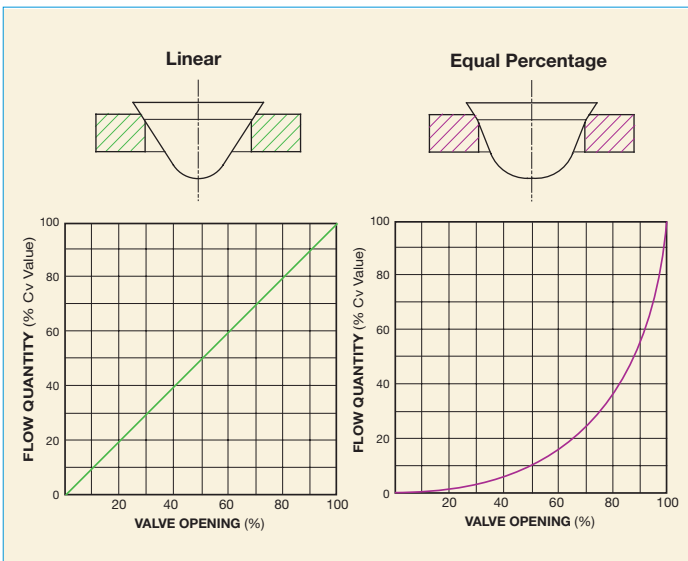

Parts List (Sizes 1/2" - 4")

PARTS			
NO.	DESCRIPTION	PCS.	MATERIAL
1	Pneumatic Actuator	1	Polyester Glass Filled (PEG)
2	Actuator Spring	1	Coated Steel
3	Diaphragm	1	BUNA-N (Nitrile)
4	Actuator Valve Stem	1	316 Stainless Steel
5	Air Connection	1	1/4" FNPT
6	Actuator Standoffs	2	316 Stainless Steel
7	Position Indicator	1	Nylon Coated Steel
8	Bellows Seal O-Ring	1	EPDM, FKM, PTFE Encapsulated FKM
9	Bellows Housing	1	PVC, PP, PVDF, PTFE
10	Body O-Ring	1	EPDM, FKM, PTFE Encapsulated FKM
11	Bellows	1	PTFE
12	Seat O-Ring	1	EPDM, FKM, PTFE Encapsulated FKM
13	Valve Seat	1	PVC, PP, PVDF, PTFE
14	Valve Plug	1	PVC, PP, PVDF, PTFE
15	Valve Body	1	PVC, PP, PVDF, PTFE

Sample Specification

All Thermoplastic modulating control valves shall be of the Globe Valve design. Valves shall have interchangeable seat and plugs to accommodate various flow coefficients (Cv) and flow characteristics shall be either linear or equal percentage. Stem seal shall be PTFE and of the bellows design. Pneumatic actuator shall be constructed of glass-filled polyester (PEG) with SS trim. Actuator shall have 1/4" FNPT air connections and a visual position indicator. PVC shall conform to ASTM D1784 Cell Classification 12454-A, PP conforming to ASTM D4101 Cell Classification PPO210B67272, and PVDF conforming to ASTM D3222 Cell Classification Type II. and PTFE shall conform to PTFE TFE 1600, as manufactured by AsahiAmerica, Inc. *ASAHI/AMERICA RECOMMENDS THE USE OF AV GASKETS FOR THIS PRODUCT LINE*

Caution

- Never remove valve from pipeline under pressure.
- Always wear protective gloves and goggles.

Globe Control Valves

PVC/PP

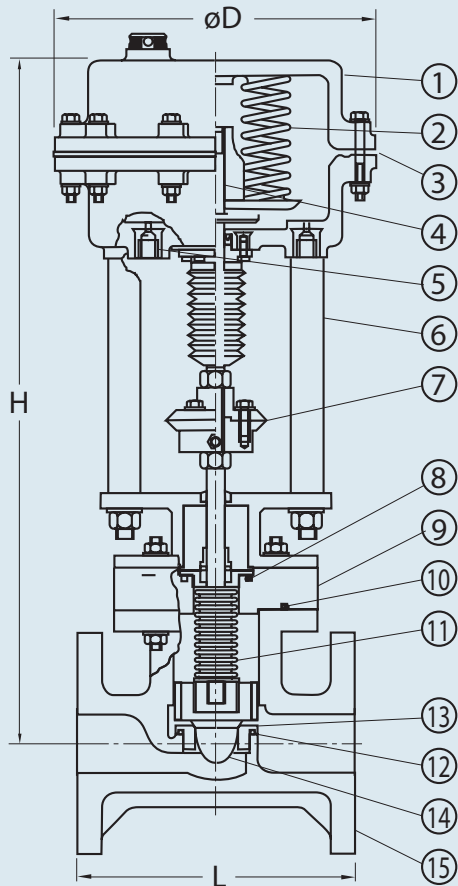

PVDF/PTFE

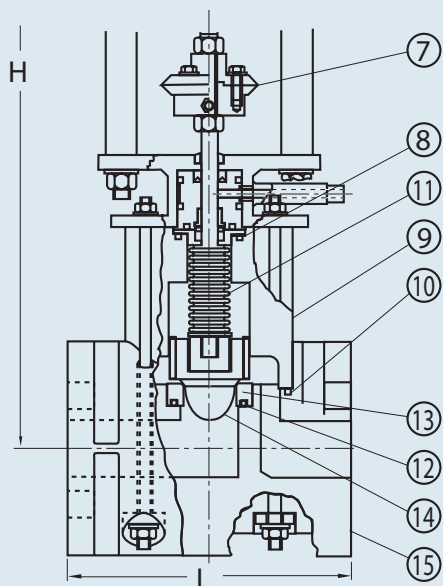

Dimensions (INCHES)

NOMINAL SIZE		PVC, PP			PVDF, PTFE		
INCHES	mm	L	H	D	L	H	D
1/2	15	3.35	16.54	8.66	5.12	17.71	8.66
3/4	20	3.74	16.54	8.66	5.91	17.91	8.66
1	25	4.33	16.73	8.66	6.30	17.91	8.66
1 1/4 *	32	5.31	16.93	8.66	7.09	18.11	8.66
1 1/2	40	7.48	17.13	8.66	7.87	18.31	8.66
2	50	7.87	18.51	8.66	9.06	18.50	8.66
2 1/2	65	8.66	18.70	8.66	11.42	18.70	8.66
3	80	9.45	20.08	8.66	12.20	19.88	8.66
4	100	11.42	20.28	8.66	13.78	20.37	8.66

* PP Not Available

Operating Pressure vs. Temperature

(PSI, WATER, NON-SHOCK)

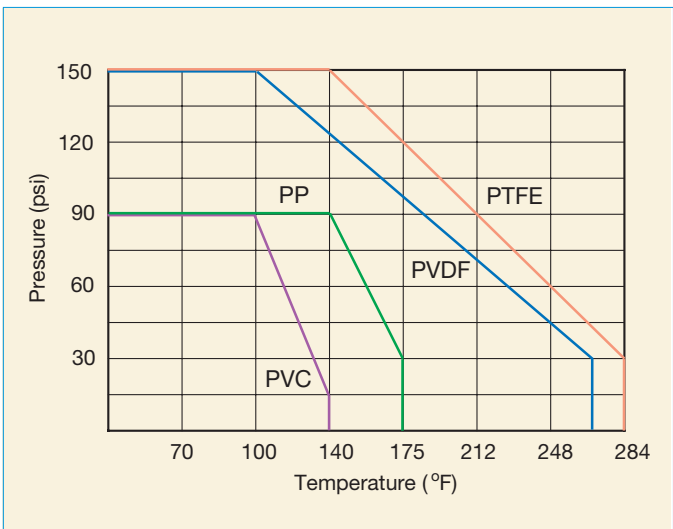

Troubleshooting

What if fluid flows even when fully closed?

1. Plug or seat is damaged. Change plug or seat.
2. Foreign matter caught or formed at plug and seat.
3. Air not completely exhausted.

What if it does not open?

1. Actuator diaphragm is damaged or worn. Replace.
2. Operating air pressure is low.

What if fluid leaks from body?

1. Bolts for bellows housing and body are loose. Retighten
2. O-ring(s) chemically attacked.

Globe Control Valves

Cv Values for PVC and PP

SEAT DIA.	VALVE SIZE (INCHES)									
	INCHES	1/2	3/4	1	1 1/4	1 1/2	2	2 1/2	3	4
.106	.23									
.149	.46									
.185	.70									
.236	1.20									
.299	1.75	1.75								
.374	2.60	2.60	2.6							
.404		4.00	4.0	4.0						
.578		6.10	6.1	6.1	6.1					
.748				9.5	9.5	9.5				
.944				10.5	10.5	10.5	10.5			
1.181					16.0	16.0	16.0	16.0		
1.496						25.0	25.0	25.0	25.0	
1.909							40.0	40.0	40.0	
2.047							46.0	46.0	46.0	
2.244								64.0	64.0	
2.696									81.0	
2.897									93.0	

Cv Values for PVDF and PTFE

SEAT DIA	VALVE SIZE (INCHES)									
	INCHES	1/2	3/4	1	1 1/4	1 1/2	2	2 1/2	3	4
.106	.23									
.149	.46									
.185	.70									
.236	1.20									
.299	1.75	1.75								
.374	2.60	2.60	2.6							
.404		4.00	4.0	4.0						
.578		6.10	6.1	6.1	6.1					
.748				10.5	10.5	10.5	10.5			
.944					14.0	14.0	14.0	14.0		
1.181					18.0	18.0	18.0	18.0	18.0	
1.496						29.0	29.0	29.0	29.0	29.0
1.909							40.0	40.0	40.0	40.0
2.047								52.0	52.0	52.0
2.244									70.0	70.0
2.696										93.0
2.897										105.0

REQUIRED DATA FOR CONTROL VALVE SIZING

SERVICE CONDITIONS			
1. Media			Concentration %
2. Temperature:	°F	or	°C Specify
3. Flow Required (gpm):	Max.	Normal	Min.
4. Line Pressure (psi):	Upstream:	Downstream:	(Max. Flow)
5.	Upstream:	Downstream:	(Norm. Flow)
6.	Upstream:	Downstream:	(Min. Flow)

VALVE SPECS			
7. Line Size:			
8. Valve Characteristics:	Equal % or Linear:		Specify
9. Valve Material:			Valve Seals:
10. Cv Value Required:	Max.:	Norm.:	Min.:

ACTUATOR SPECS			
11. Actuator Type:	Electric or Pneumatic		Specify
12. Supply Voltage for Electric:			Specify
13. Electric Control Signal:		mA or volts	
14. Pneumatic Control Signal:		PSI	
15. Position Feedback:			Specify