



3-WAY AND 4-WAY PTW/PFW VALVES TECHNICAL SPECIFICATIONS



General Specifications

Style:

3- and 4-Way Tapered Plug Valves.

Materials:

Cast Iron, ASTM A126, Class B
Aluminum, ASTM B26, Alloy 713.0
Carbon Steel, ASTM A216, Grade WCB
316 Stainless Steel, ASTM A351, CF8M
Cast Iron body with hard natural rubber lining.
Flange faces and all internal surfaces are lined.

Sizes:

3–16" (80–400mm)

End Connections:

ANSI Class 150 flanged
Flanged with BS4504 and DIN, PN 10 drilling
Flanged with BS4504 and DIN, PN 16 drilling
Flanged, Class 150 BS Table D
Flanged, Class 150 BS Table E
Flanged, Class 150, JIS 10

Body Rating:

125 psi (861 kPa) C.W.P. non-shock working pressure rating.

Packing:

Acrylonitrile Butadiene, to +300°F (149°C)
PTFE, -50° to +450°F (-46° to 232°C)
Non-Asbestos Square Braided Fiberglass, to 1000°F (538°C)

Plug Styles:

Single Style Plug

Standard in all 3-Way valves to provide straight through and 90° flow combinations.

Double Style Plug

Available in all 3-Way valves to provide 90° flow combinations.

Transfer Style Plug

Standard in all 4-Way valves to provide 90° flow combinations.

Plug Facings:

Metal plug, furnished in the same material as the valve body, except cast iron which has a stainless steel plug.

Chloroprene (CR), generally recommended for alkaline services to 180°F (82°C).

Acrylonitrile Butadiene (NBR), generally recommended for temperatures to 180°F (82°C).

Chloro-Sulfonyl Polyethylene (CSM), generally recommended for oxidizing services to 200°F (93°C).

Hard Natural Rubber (NRH), generally recommended for chlorine services.

Chloro-Isobutene-Isoprene (CIIR), generally recommended for temperatures to 250°F (121°C).

Fluoro Rubber (FKM), recommended for general chemical service at elevated temperatures.

Hard Natural Rubber (NRCR) with soft rubber chloroprene plug overlay (CR) for dead-tight shutoff with lever or double handwheel actuators.

Shutoff:

Resilient plug facings provide dead-tight shutoff when used with lift, turn, reseal levers or handwheel actuators.

Valves with all-metal or hard rubber plugs do not provide drip-tight shutoff. A soft rubber overlay can be furnished on hard rubber plugs to provide dead-tight shutoff in valves with lever or lift, turn, reseal double handwheel actuators.

Bearings:

Hard rubber lined valves are furnished with hard rubber bearings; all other valves are furnished with 316 stainless steel bearings.

Options:

316 Stainless Steel Plug, ASTM A743, CF8M

Valve Selection

Cv/Kv Values

Valve Size	Straight Through Flow Cv/Kv	90° Flow* Cv/Kv
3" 80mm	240 65	195 51
4" 100mm	390 105	316 86
5" 125mm	900 240	730 195
6" 150mm	900 240	730 195
8" 200mm	1550 405	1255 335
10" 250mm	2550 700	2065 550
12" 300mm	3600 1000	2915 800
14" 350mm	4100 1020	3320 900
16" 400mm	6250 1600	5065 1400

Cv values = flow in GPM of water at 1 psi pressure drop, in 3-Way valves with flow between ports one and three.
 Kv values = flow in m³/hr. of water at 100 kPa pressure drop.
 * Cv/Kv value in 3- or 4-Way valves when flow turns 90° in the valve (flow through adjacent ports).

Flow Combinations

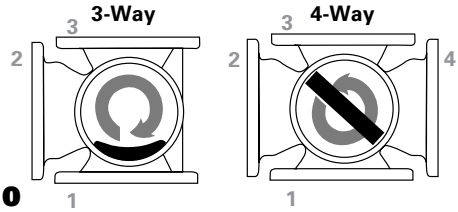

Combination 0

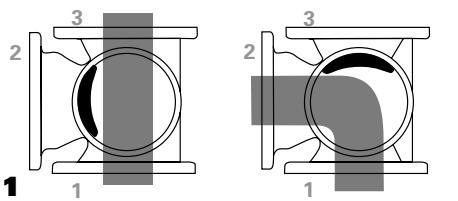

Combination 1

For tight shutoff, it is recommended that the flow be against the back side of the plug.

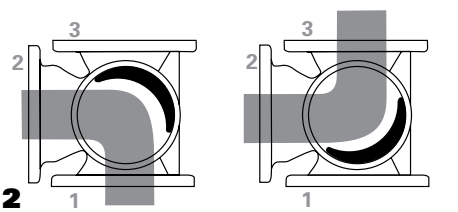

Combination 2

For tight shutoff, it is recommended that the flow be against the back side of the plug.

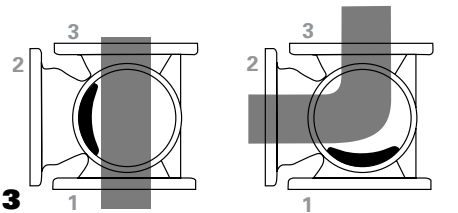

Combination 3

For tight shutoff, it is recommended that the flow be against the back side of the plug.

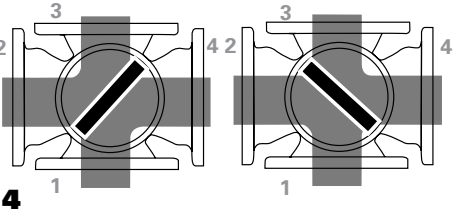

Combination 4

For tight shutoff, it is recommended that the higher pressure be from port flange number 1.

Combination Number

Combination Number	Port Open	Plug Style	Plug Rotation	Travel Stops
0	-	All	360°	No
1	1	Single	90°	Yes
2	2	Double	90°	Yes
3	3	Single	90°	Yes
4	-	Transfer	90°	Yes

Applicable Standards

DeZURIK Water Controls 3- and 4-Way Plug Valves are designed and/or tested to meet the following standards:	
ANSI B16.1	Hydrostatic Testing
ANSI B16.1 and ANSI B16.5	Flange Connection Drilling
JIS 10; DIN 10,16; BS 10-D,E,F	Foreign Standards for flange bolting
ISA-A39.2	Standard Control Valve Capacity Test Procedures for Incompressible Fluids

Pressure Ratings

CWP non-shock working pressure rating of all 3- and 4-Way valves is 125 psi (861 kPa). The maximum shutoff pressure differential must not exceed the units shown for each actuator type.

Actuator Type	Max. Shutoff Pressure Differential		
	3-Way	4-Way	
Lever	3-6" 80-150mm	125 psi 861 kPa	35 psi 241 kPa
	8 & 10" 200 & 250mm	100 psi 689 kPa	35 psi 241 kPa
Single Handwheel/Chainwheel	3-16" 80-400mm	35 psi* 241 kPa	35 psi 241 kPa
	3-16" 80-400mm	125 psi 861 kPa	35 psi 241 kPa
Double Handwheel/Chainwheel	3-16" 80-400mm	35 psi* 241 kPa	35 psi 241 kPa
	3-16" 80-400mm	125 psi 861 kPa	35 psi 241 kPa
Cylinder	3-16" 80-400mm	35 psi* 241 kPa	35 psi 241 kPa
	3-16" 80-400mm	125 psi 861 kPa	35 psi 241 kPa
Electric Motor			

Note: Cylinders are sized for full 125 CWP rating.
 *Higher maximum shutoff pressure differential available on application.

Weights

Valve for Lever Operation

Add weights of all other actuators as shown below.

Valve Size	Cast Iron, Carbon Steel and Stainless Steel		Aluminum	
	3-Way	4-Way	3-Way	4-Way
	lbs/kg		lbs/kg	
3" 80mm	55 25	65 29	25 11	32 15
4" 100mm	105 48	125 57	50 23	60 27
5" 125mm	160 73	175 79	100 45	110 50
6" 150mm	165 75	180 82	110 50	125 57
8" 200mm	250 113	275 125	125 57	135 61
10" 250mm	370 168	430 195	240 109	300 136
12" 300mm	500 227	560 254	300 136	360 163
14" 360mm	650 295	715 324	360 163	425 193
16" 400mm	1070 485	1120 508	650 295	700 318

Levers

Valve Size	Weight lbs/kg
3 & 4" 80 & 100mm	3 1
5 & 6" 125 & 150mm	4 2
8 & 10" 200 & 250mm	5 2
12" 300mm	8 4
14 & 16" 350 & 400mm	10 5

Actuators

Add valve weights above.

Valve Size	Single Handwheel	Double Handwheel	Single Chainwheel*	Double Chainwheel*	On-Off Cylinder	Cylinder with Positioner
	lbs/kg					
3" 80mm	55 25	62 28	66 30	84 38	72 33	84 38
4" 100mm	58 26	75 34	69 31	97 44	93 42	105 48
5 & 6" 125 & 150mm	58 26	75 34	69 31	97 44	115 52	127 58
8" 200mm	63 29	70 32	79 36	97 44	115 52	127 58
10" 250mm	166 75	177 80	182 83	209 95	250 113	262 119
12" 300mm	183 83	194 88	220 100	247 112	250 113	262 119
14" 360mm	183 83	194 88	220 100	241 109	310 141	322 146
16" 400mm	186 84	197 89	223 101	250 113	310 141	322 146

* Chain for chainwheel actuators — 0.5 lbs (0.2 kg) per foot.

Note: Net weight in pounds (kilograms) — Weights are approximate and do not include crating.

Accessories

Add to valve and actuator weight.

Extension Fittings for Lever Actuated Valves (CODE EL)

Fittings Only = 10 lbs (5 kg)

Extension Pipe/Per Foot = 4 lbs (2 kg)

Floorstand for Lever Actuated Valves (CODE FS)

Floorstand Only = 95 lbs (43 kg)

Extension Pipe/Per Foot = 4 lbs (2 kg)

Floorstand for Handwheel Actuated Valves (CODE FSDI)

Floorstand Only = 95 lbs (43 kg)

Extension Rod (Code ER)/Per Foot = 2 lbs (1 kg)

Solenoid Valve (CODE 4V) = 7 lbs (3 kg)

Position Indicating Switch (CODE SE) = 6 lbs (3kg)

Control Station Pneumatic (CODE CNP) = 8 lbs (4 kg)

Ordering

To order, simply complete the valve order code from the information shown. An ordering example is shown for your reference.

Valve Style

Give valve style code as follows:

PTW = Plug 3-Way
PFW = Plug 4-Way

Valve Size

Give valve size code as follows:

3 = 3" 80mm	10 = 10" 250mm
4 = 4" 100mm	12 = 12" 300mm
5 = 5" 125mm	14 = 14" 350mm
6 = 6" 150mm	16 = 16" 400mm
8 = 8" 200mm	

End Connection

Give valve size code as follows:

F1 = Flanged, ANSI Class 150
F110 = Flanged, Class 150, DIN 10 or BS 4504/10
F116 = Flanged, Class 150, DIN 16 or BS 4504/16
F1D = Flanged, Class 150, BS Table D
F1E = Flanged, Class 150, BS Table E
F1J1 = Flanged, Class 150, JIS 10

Body Material

Give body material code as follows:

CI = Cast Iron
AL = Aluminum
CS = Carbon Steel
S2 = 316 Stainless Steel
CIH = Cast Iron, Hard Rubber Lined

Note: CIH bodies available with NRH or NRCR plug facing only.

Packing

Give packing code as follows:

6 = Acrylonitrile-Butadiene to 300°F (150°C)
Standard in all valves except cast iron hard rubber lined bodies (CIH)
7 = PTFE -50°F to 450°F (-46°C to 233°C)
8 = Fiberglass, Braided to 1000°F (540°C)

Plug Style

Give plug style code as follows:

3-Way Valves	4-Way Valves
S = Single	T = Transfer
D = Double	

Combination Number

3-Way Valves	4-Way Valves
0 = Combination 0	0 = Combination 0
1 = Combination 1	4 = Combination 4
2 = Combination 2*	
3 = Combination 3	

Note: Combination 0 available with cylinder actuators on application.
*Combination 2 requires double plug style.

Plug Facing

Give plug facing code as follows:

M = Metal (Same material as body except cast iron which has a stainless steel plug.)
CR = Chloroprene to 180°F (83°C)
NRH = Hard Natural Rubber
Plug facing for Cast Iron Hard Rubber Lined Valves (CIH) to 180°F (83°C)
CIIR = Chloro-Isobutene-Isoprene to 250°F (122°C)
NBR = Acrylonitrile-Butadiene to 200°F (94°C)
CSM = Chloro-Sulfonyl Polyethylene to 200°F (94°C)
FKM = Fluoro Rubber to 400°F (200°C) NRCR = Hard natural rubber with soft Chloroprene overlay (CIH bodies only) to 180°F (83°C)
NRCR = Hard natural rubber with soft Chloroprene overlay (CIH bodies only) to 180°F (83°C)

Note: Cylinder actuators should be used with metal plugs. Cylinders are not recommended for use with resilient faced plugs. GS actuators are not available with resilient faced plugs.

Options

Give options codes as follows:

S2 = 316 Stainless Steel Plug

Actuators & Accessories

All actuators must be ordered by adding the actuator code to the basic valve order code. Refer to the following pages for descriptions and ordering information.

Ordering Example:

PTW,4,F1,CI,6,S-1-M*

Lever Actuators

3- and 4-Way valves through 10" (250mm) size can be furnished with levers to provide the lowest cost control. However, handwheel or powered actuators are recommended for easier operation, for applications exceeding listed shutoff pressures and where sudden valve closure may cause water hammer. Levers can provide full 360° plug rotation or can be furnished with stops to limit plug travel, as indicated by combination number. In addition, lever actuated valves include a locking screw to lock the plug in the desired position.

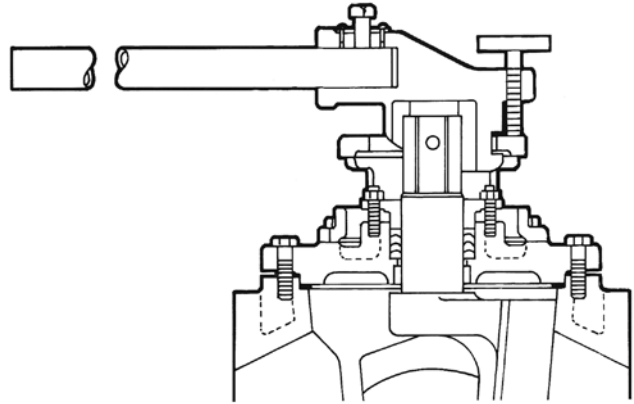

Ordering Valve for Lever Actuation (LV)

Order lever actuated valves by giving complete valve order code followed by the code LV. Levers are removable and must be ordered separately (see LVT below).

Ordering Example:
PTW,4,F1,C1,6,S-1-M*LV

Ordering Levers (LVT)

Order as a separate item by giving code ACC*LVT followed by the appropriate size code as shown in the sizing chart.

Ordering Example:
ACC*LVT102

Sizing Chart

Valve Size	Code
3" 80mm	101
4" 100mm	102
5 & 6" 125 & 150mm	103
8" 200mm	104
10" 250mm	105

Note: Contact Application Engineering for lever actuators on larger valve sizes.

Accessories for Lever Actuated Valves

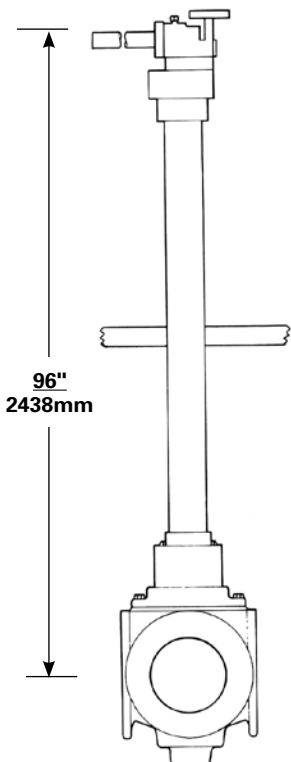

Extended Lever

Allows remote operation of 3–10" (80–250mm) valves. Includes external extension pipe to extend handle as well as internal extension pipe and fittings. To order, add the code EL to the valve identification. Specify the required length from the centerline of valve to centerline of the handle below valve order code.

Ordering Example:
PTW,4,F1,C1,6,S-O-M*LV,EL
Centerline of valve to centerline of handle 96" (2438mm).

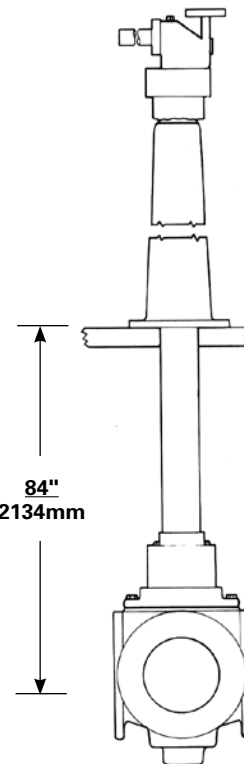

Floorstand

Allows remote valve operation of 3–10" (80–250mm) valves from the floorstand. Includes floorstand, fittings, and EL extension pipe. To order, add FS to the valve identification. Specify the required length from the centerline of valve to the base of the floorstand below the valve order code. Maximum is 13' (396cm).

Ordering Example:
PTW,4,F1,C1,6,S-O-M*LV,EL,FS
Centerline of valve to base of floorstand 84" (2134mm).

Handwheel Actuators

Double Handwheel Actuators

Lift, turn, reset double handwheel actuators provide dead-tight shutoff when used on valves with resilient faced plugs. The totally enclosed and sealed construction protects moving parts from damage or corrosion. Continual lubrication is not required for operating ease. The heavy-duty, corrosion resistant bearings in the actuator assure lasting easy valve operation and overall reliability. Actuator castings, gears and shafts also add to reliability by assuring permanent alignment of moving parts for smooth, easy operation.

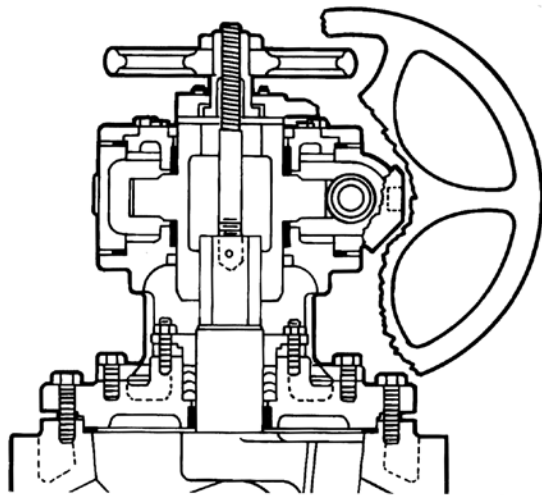

Single Handwheel Actuators

Single handwheel actuators are only for use with valves having metal or hard rubber lined plugs which do not provide dead-tight shutoff. Totally enclosed, single handwheel actuators are also furnished with corrosion resistant bearings and feature the same heavy-duty construction as double handwheel models. In single handwheel models, a threaded collar acts to adjust clearance between the plug and seat. Plug-to-seat clearance can be adjusted easily by turning the collar. It is not necessary to completely disassemble the actuator.

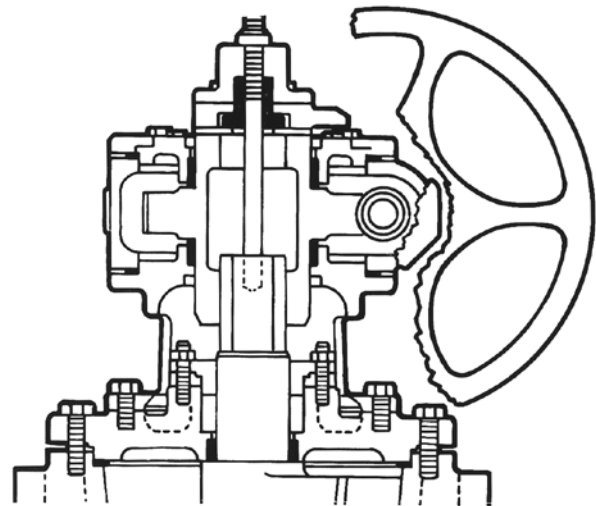

Ordering Handwheel Actuators

To order, add the appropriate actuator code to the valve order code. Both single and double handwheel actuators can provide 90° or 360° plug rotation. The combination number in the valve order code indicates plug travel requirements.

Valve Size	Actuator Number	
	Double Handwheel	Single Handwheel
3-6" 80-150mm	GSL-6-HD8	GS-6-HD8
8" 200mm	GSL-6-HD12	GS-6-HD12
10" 250mm	GSL-12-HD12	GS-12-HD12
12 & 14" 300 & 350mm	GSL-12-HD16	GS-12-HD16
16" 400mm	GSL-12-HD20	GS-12-HD20

Actuator Mounting

Standard, 90°, 180° and 270° are the preferred mounting positions. However, actuators can be mounted at 30° increments from standard, with the following exceptions. Mounting position 210° clockwise from standard is not available on 16" (400mm) 3- and 4-Way valves. Mounting position 30° clockwise is not available on 16" (400mm) 4-Way valves. Specify mounting other than standard below valve and actuator identification.

Ordering Example:

PTW,4,F1,CI,6,S-1-M*GS-6-HD8

Actuator mounted 90° clockwise from standard.

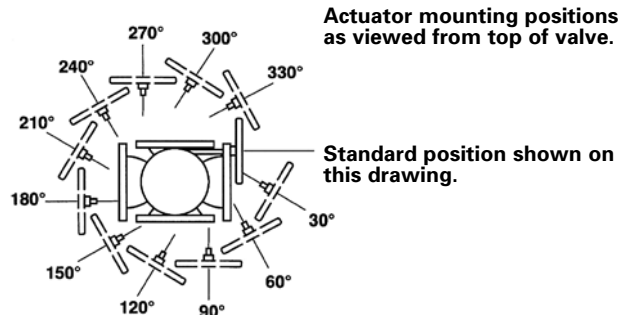

Accessories - Single Handwheel Actuators

Dial Indicating Floorstand (FSDI)

For use with single handwheel actuators with combination numbers 1, 2, 3 or 4 (90° rotation). Provides remote operation of valve. Includes floorstand, fittings, dial, and handwheel mounted on the floorstand. The extension rod must be ordered separately. To order floorstand, add FSDI to the valve and actuator order code.

Ordering Example:

PTW,4,F1,CI,6,S-1-M*GS-6-HD8,FSDI

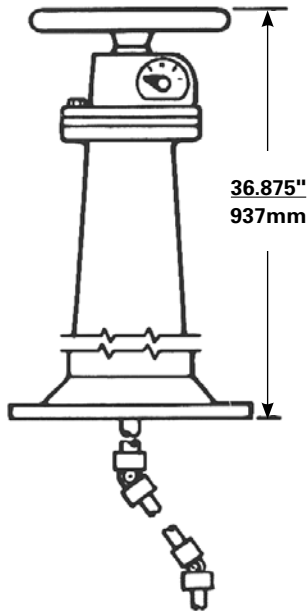

Neck Extension (ENK)

For use on all manual and powered G-Series Actuators. Included is an extended valve neck and shaft.

Ordering

To order as part of a complete valve and actuator assembly, add "ENK" to the valve/actuator ordering code. Below neck extension characteristic, specify C/L of valve to top of extension flange. If extension exceeds 21 feet, contact Application Engineering.

Ordering Example:

PTW,4,F1,CI,6,S-O-M*GS-6-HD8,ENK

C/L of valve to top of extension flange – 60.38" (1534mm).

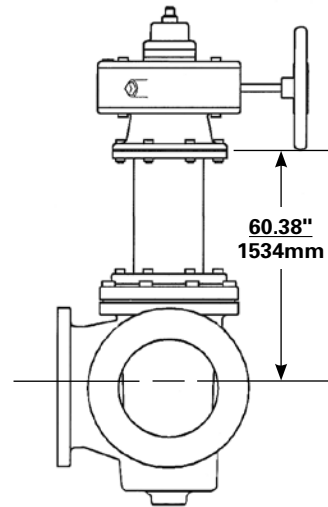

Extension Rod for Floorstand (ER)

For use with Dial Indicating Floorstand (FSDI) on single handwheel actuated valves. Order as a separate item by giving code ACC*ER followed by the appropriate code as shown in the chart. Give required rod length from the centerline of the valve to the base of the floorstand below the valve order code.

Actuator Size	Code
GS-6	101
GS-12	102

Ordering Example:

ACC*ER,101

Centerline of valve to base of floorstand 96" (2440mm).

Valve Size	Min. C/L Valve to Top of Flange
3" 80mm	13.75 349
4" 100mm	14.38 365
6" 150mm	15.88 403
8" 200mm	17.38 442
10" 250mm	18.75 476
12" 300mm	19.75 502
14" 350mm	21.25 540
16" 400mm	23.63 600

Inch
Millimeter

Chainwheel Actuators

Chainwheel actuated valves are furnished with chainwheels and chain guides. To order chainwheel actuated valves, add the actuator code, as listed in the chart, to the valve order code. The chain must be ordered separately — one length for single chainwheel actuators and two lengths for double chainwheel actuators.

Valve Size	Double Chainwheel	Single Chainwheel
3-6" 80-160mm	GSL-6-CW8	GS-6-CW8
8" 200mm	GSL-6-CW12	GS-6-CW12
10" 250mm	GSL-12-CW12	GS-12-CW12
12-16" 300-400mm	GSL-12-CW20	GS-12-CW20

Note: Double chainwheel actuators available on 3-Way valves only.

Galvanized Chainwheel and Guide

To order for chainwheel actuators, specify galvanized below the actuator order code.

Actuator Mounting

Specify actuator mounting positions other than standard as on handwheel actuators. Standard actuator mounting is the same as for handwheel actuators.

Standard Chain

For single chainwheel actuators, and for the side chainwheel on double handwheel actuators. Order standard chain as a separate item by giving code ACC*CN102 and specify length of chain below the order code. Galvanized chain may be ordered by order code ACC*CN103.

Ordering Example:

ACC*CN102

Chain: 12 feet

Babbitt Chain

Double chainwheel actuators have two chainwheels, each requiring a different type of chain. In addition to one length of standard chain, 1 length of Babbitt chain must be ordered for lift, turn and reseal chainwheel actuators. Order as a separate item by giving code ACC*CN followed by the appropriate code as shown in the chart. Specify the required length of chain below the order code.

Gear Unit	Babbitt Chain Code
GSL-6	104
GSL-12	105

Ordering Example for Double Handwheel Actuators:

ACC*CN104

Chain: 12 feet

ACC*CN102

Chain: 12 feet

Cylinder Actuators

Cylinder actuators include both on-off and positioning, double-acting models. Actuators can be used with either pneumatic or hydraulic supply. They provide 90° rotation and can be used with 3- and 4-Way valves which have all-metal or hard rubber lined plugs only. Valves with cylinder actuators do not provide dead-tight shutoff.

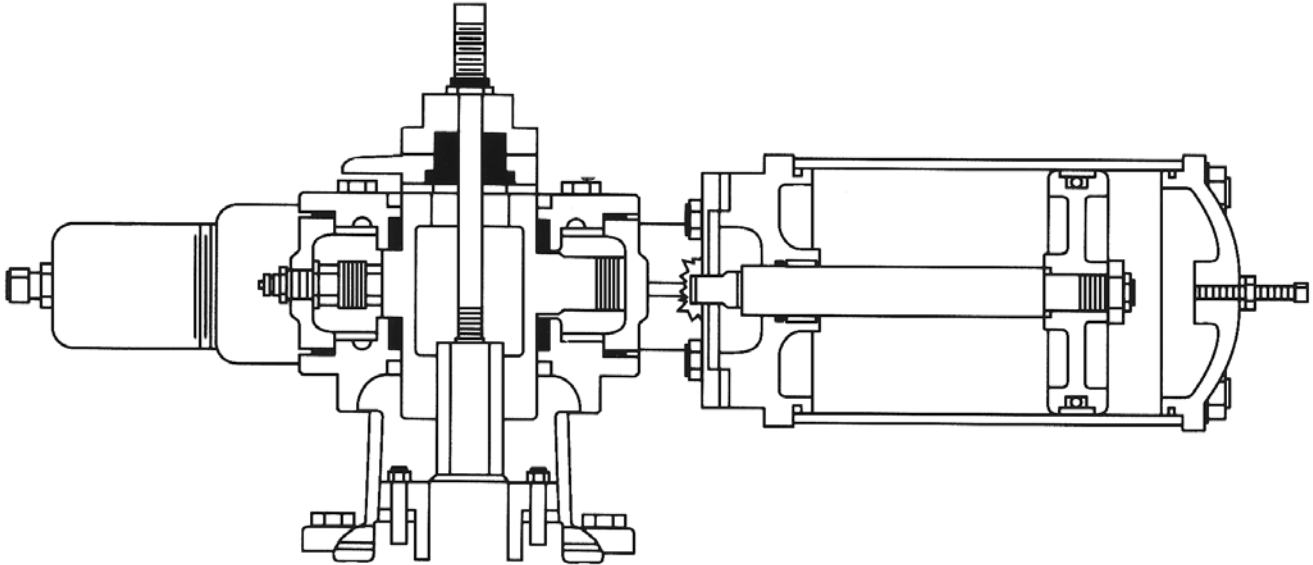

Plug Adjusting Device

A threaded collar maintains constant clearance between the plug and seat to assure smooth valve operation. Plug-to-seat clearance is easily adjusted by turning the collar.

Manual Valve Operation

A manual nut connected to the valve stem allows manual valve operation in case of supply failure.

Enclosed Actuator Housing

The cast iron actuator housing is sealed to prevent the entry of dirt, moisture and contaminants. Lubrication is not required for smooth operation, even on continuous throttling applications.

Corrosion Resistant Bearings

Heavy-duty bearings provide support and minimize friction to assure smooth operation and throttling action.

Rugged Cylinder Construction

The cylinder construction features durable gears, pistons and piston rods to add reliability and smooth operation. A PTFE piston guide ring provides support for the piston. This, plus a piston rod bearing, makes piston action smooth and prevents sticking.

Optional Hydraulic Cylinder (Water Fitted)

The optional hydraulic actuator includes: cast iron construction, plastic coated wetted parts to prevent corrosion, stainless steel piston rod, multiple lip rod seal with an adjustable gland that does not require disassembly for replacement, and a polyurethane scraper with metal backup located inside the head of the cylinder to prolong the life of the seal.

Cylinder Actuators

Ordering Cylinder Actuators

To order cylinder actuators, add the actuator number from the following chart to the valve order code. Also add the code letter "A" or "B" to indicate the appropriate actuator mounting for the combination number.

Supply pressure is 50–100 psi (345–689 kPa). When ordering hydraulic actuators, specify supply media if oil or water.

Preferred mounting positions are standard, 90°, 180° and 270°. However, actuators can be mounted at 30 degree increments clockwise from standard.

Ordering Example:

PTW,4,F1,CI,6,S-1-M*GS-6-PC6-A

Actuator mounted 180° from standard.

Sizing Chart

Valve Size	Actuator
3" 80mm	GS-6-PC6
4" 100mm	GS-6-PC6
5–8" 125–200mm	GS-6-PC8
10–12" 250–300mm	GS-12-PC8
14–16" 350–400mm	GS-12-PC10

Mounting Code

A code letter from the mounting chart must be added to the cylinder actuator ordering code. Select the appropriate code based on valve style, combination number, and actuator mounting.

Code	Actuator Mounting
A	4-Way Valves - Combination 4 or 3-Way Valves - Combination 1 with actuator mounted standard or 60°, 120°, 180°, 240° or 300° clockwise from standard.
	3-Way Valves - Combination 2 or 3 with actuator mounted 30°, 90°, 150°, 210°, 270° or 330°.
B	3-Way Valves - Combination 2 or 3 with actuator mounted standard or 60°, 120°, 180°, 240° or 300° clockwise from standard.
	4-Way Valves - Combination 4 or 3-Way Valves - Combination 1 with actuator mounted 30°, 90°, 150°, 210°, 270° or 330° clockwise from standard.

Positioning Cylinder Actuators

Accurate positioners provide precise throttling control. A variety of models are available including pneumatic, hydraulic and electronic. Positioners are enclosed and mounted on the actuator.

The unique DeZURIK Water Controls method of mounting positioners eliminates backlash in the positioner feedback system. A cam mounted solidly to the plug stem and spring loaded cam follower always transmit exact plug position. Positioner feedback is directly from the valve stem. Span and zero adjustments are simple and readily accessible. High gain and high positioner capacity, along with properly sized actuators, assure pneumatic control.

Ordering

To order, specify positioner model and desired signal range by adding positioner code from the chart on page 12 to the valve and actuator order code. Also specify positioner action.

On 3-Way Valves, specify air-to-open port number _____ (port other than the combination number).

On 4-Way Valves, air-to-open port number _____ (2 or 4) to port number 1 (Port No. 1 is always open).

Ordering Example:

PTW,4,F1,CI,6,S-1-M*GS-6-PC6-A,P36C,AFR2,G

Air-to-open port number 2.

3–15 psi (20–103 kPa) signal range.

Positioning Cylinder Actuators (continued)

Positioner Specifications

Order Code	P36C	P41C	P41D
Air Supply (psi)*	29-145 psi (200-1000 kPa)	29-145 psi (200-1000 kPa)	29-120 psi (200-830 kPa)
Linearity	< 0.50% of full scale	< 0.75% of full scale	±0.25% of full scale
Hysteresis	< 0.75% of full scale	< 1% of full scale	0.75% of full scale
Repeatability	< 0.5% of full scale	< 0.5% of full scale	0.25% of full scale
Accuracy	0.25% of full scale	0.25% of full scale	0.2% of full scale
Air Consumption	0.71 SCFM @ 87 psi (20 nl/min @ 600 kPa)	0.78 SCFM @ 87 psi (22 nl/min @ 600 kPa)	0.71 SCFM @ 87 psi (20 nl/min @ 600 kPa)
Air Delivery	18.8 SCFM @ 87 psi (540 nl/min @ 600 kPa)	18.8 SCFM @ 87 psi (540 nl/min @ 600 kPa)	19.2 SCFM @ 87 psi (550 nl/min @ 600 kPa)
Input Impedance	-	260 ohms	240 ohms
Temperature Range	-5° to 185°F (-20° to 85°C)	-5° to 185°F (-20° to 85°C)	14° to 150°F (-10° to 65°C)
Weight	3.0 lbs (1.4 kg)	3.7 lbs (1.7 kg)	5.4 lbs. (2.7 kg)

* Check maximum pressure of actuator; regulator may be required.

Positioners	Order Code
P36C, 4-Way Pneumatic, Direct or Reverse Acting Positioner Can be used as a 3-Way by plugging one port. Specify 3-15, 3-9 or 9-15 as second line information. Specify as second line information if increasing signal should open or close valve.	P36C
P41C, 4-Way Electronic, Direct or Reverse Acting Positioner Can be used as a 3-Way by plugging one port. Specify 4-20, 4-12 or 12-20 mA signal as second line information. Specify as second line information if increasing signal should open or close valve. Explosion-proof Cenelec (metric connection) FM & CSA (NPT connection)	P41C P41C-EX4 P41C-EX7
P41D, 4-Way Electronic, Direct or Reverse Acting Positioner Can be used as a 3-Way by plugging one port. Specify 4-20, 4-12 or 12-20 mA signal as second line information. Specify as second line information if increasing signal should open or close valve.	P41D

Three lobe cam is standard: Linear characterized full span, 0 - 50% and 50% split range lobes.

Gauges

Positioner	Usage	Order Code
Pneumatic Positioners 3 Gauges mounted: Supply 0-100 psi Output 0-100 psi Signal 0-30 psi	P36C	G
Electronic Positioners 2 Gauges mounted: Supply 0-100 psi Output 0-100 psi	P41C, P41D	G

Air Filters for Positioners

It is required that one of these air filters be in the air supply line of every P36C, P41C and P41D electronic positioner as a primary dirt filter.

Filter	Order Code
Air Filter	AFR2
	AFS

Accessories – Cylinder Actuators

Speed Control Valves

To control valve opening or closing speed on pneumatic actuators. Adjustable. Mounted. Must be ordered as part of a complete valve and actuator assembly.

Speed Control Valves	Ordering Code
2 speed controls	SP
1 speed control to control closing	SPC
1 speed control to control opening	SPO

Ordering Example:

PTW,6,F1,CI,6,S-1-M*GS-6-PC8-A,SPO

Control Panel/Manual Loading Station

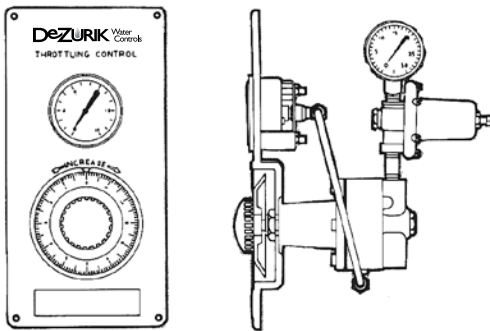

For all positioning actuators with pneumatic signal positioners. 3–15 psi (21–103 kPa). Panel mounted. Includes signal output gauge and pressure reducing valve. Order as a separate item by giving code ACC*CNP025.

4-Way Diaphragm Pilot Valve (4VD)

For use with double-acting pneumatic cylinders only. Order as separate item by giving ACC*4VD025. To order as part of a complete valve/actuator assembly, enter 4VD025 after valve/actuator code.

Ordering Example:

PTW,6,F1,CI,6,S-1-M*GS-6-PC8-A,4VD025

On/Off Air Switch (SA)

Normally used with 4VD 4-Way Diaphragm Pilot Valve. Must be ordered as a separate item.

Ordering Example:

ACC*SA025

Position Indicating Switches (SEH)

For use on GS actuators. To order switches, refer to bulletin 83.00-1.

Manual Loading Station (CNP)

For use on all positioning actuators. Panel mounted, 3–15 psi (21–103 kPa) output. Includes signal output gauge and pressure reducing valve. Order as a separate item by entering ACC*CNP025.

3- & 4-Way Solenoid Valve (3V & 4V)

For use on cylinder actuators. To order solenoids, refer to bulletin 84.00-1.

4-Way Control Valve (CV)

For use on double-acting cylinder actuators. Order as a separate item by giving ACC* followed by appropriate 3-digit code from the table below. To order as part of a complete valve/actuator assembly, enter code from table below to the valve/actuator order code.

Pneumatic Actuators

Valve Size	NPT Size	Order Code
All Sizes	.25" 6.4mm	CV201

Hydraulic Actuators

Valve Size	NPT Size	Order Code
4–8" 100–200mm	.375" 9.5mm	CV202
10–36" 250–900mm	.5" 13mm	CV203

Ordering Example:

ACC*CV201 (separate item)

Ordering Example:

PTW,6,F1,CI,6-1-M*GS-6-PC8-A,CV20

Air Filter Regulator (AFR2)

For use on all pneumatic actuators. To order, refer to bulletin 83.00-2.

Filter/Strainer (FH/FP)

Filter for pneumatic actuators, strainer for hydraulic actuators. Order as a separate item per table below (not mounted).

Description	Order Code
Pneumatic Filter	ACC*PCFP
Hydraulic Strainer	ACC*PCFH

Ordering Example:

ACC*PCFP

Electric Motor Actuators

Electric motors offer reliable and economical valve operation on 3- and 4-Way valves with metal and hard rubber lined plugs. Valves with these plugs do not provide dead-tight shutoff. When ordering electric motor actuators, specify electrical characteristics, flowing media, pressure drop, speed of operation, and actuator accessories or controls required.

Dimensions

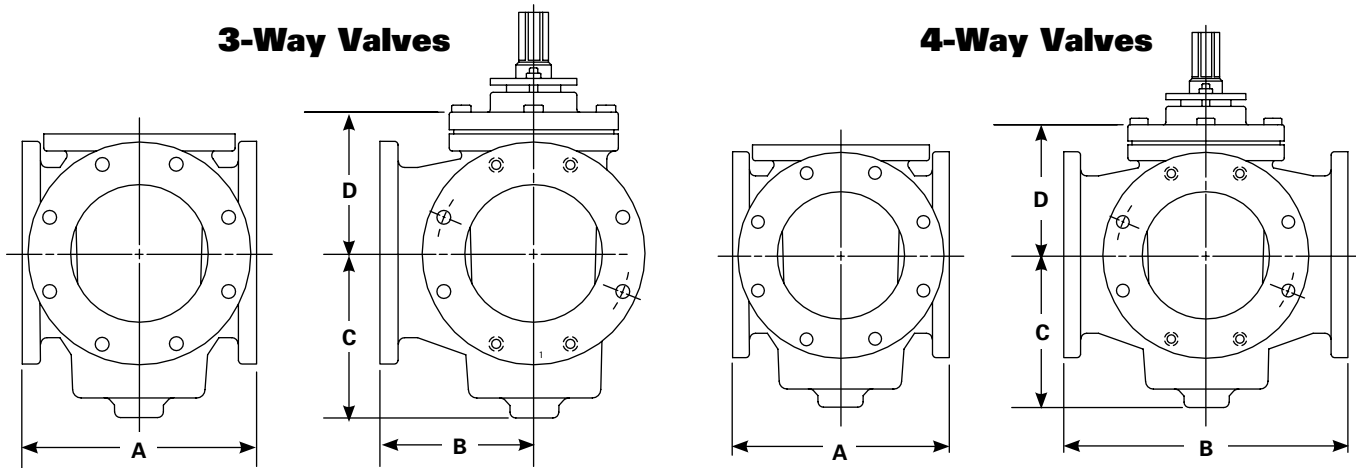

Material Groups

- Group 1 = Cast Iron, Aluminum
- Group 2 = Carbon Steel
- Group 3 = Stainless Steel, Alloys
- Group 4 = Cast Iron/Hard Rubber Lined

Basic Valve

Dimensions											
Valve Size	A			B						C	D
				3-Way Valves			4-Way Valves				
	Group 1	Group 2 & 3	Group 4	Group 1	Group 2 & 3	Group 4	Group 1	Group 2 & 3	Group 4		
3" 80mm	8.00 203	7.88 200	8.25 210	5.50 140	5.38 137	5.62 43	11.00 279	10.75 273	11.25 286	5.44 138	4.94 126
4" 100mm	9.88 251	9.75 248	10.12 257	6.50 165	6.38 162	6.62 168	13.00 330	12.75 324	13.25 337	6.62 168	5.44 138
5 & 6" 125 & 150mm	11.62 295	11.38 289	11.88 302	8.00 203	7.88 200	8.12 206	16.00 406	15.75 400	16.25 413	7.94 202	6.69 170
8" 200mm	13.88 353	13.62 346	14.12 359	9.00 229	8.81 224	9.12 232	18.00 457	17.62 448	18.25 464	9.69 246	8.56 217
10" 250mm	16.75 425	16.38 416	17.00 432	11.00 279	10.75 237	11.12 282	22.00 559	21.50 546	22.25 565	12.56 319	10.06 256
12" 300mm	19.00 483	18.62 473	19.25 489	11.56 294	11.31 287	11.69 297	23.12 587	22.62 575	23.38 594	13.44 341	11.06 281
14" 360mm	21.00 533	20.50 521	21.25 540	12.50 318	12.25 311	12.62 321	25.00 635	24.50 622	25.25 641	14.38 365	12.31 313
16" 400mm	23.75 603	23.25 591	24.00 610	15.12 384	14.88 378	15.25 387	30.25 768	29.75 756	30.50 775	15.88 403	14.69 373

Inches
Millimeters

Lever Actuator

Valve Size	E	F
3" 80mm	12.56 319	9.25 235
4" 100mm	13.56 344	14.25 362
5 & 6" 125 & 150mm	14.81 376	17.75 451
8" 200mm	16.69 424	26.25 667
10" 250mm	20.00 508	36.00 914

Inch
Millimeter

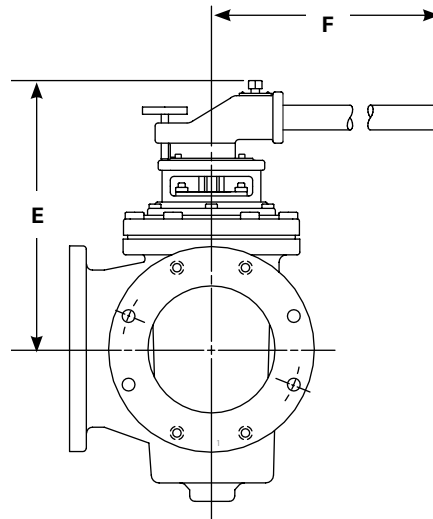
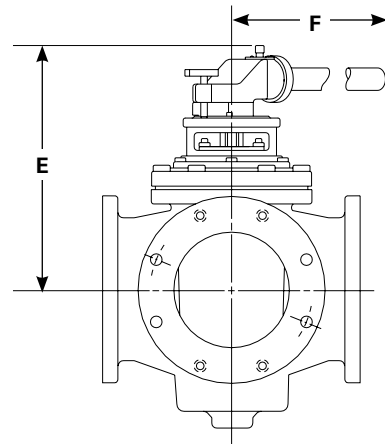

Single Handwheel/Chainwheel

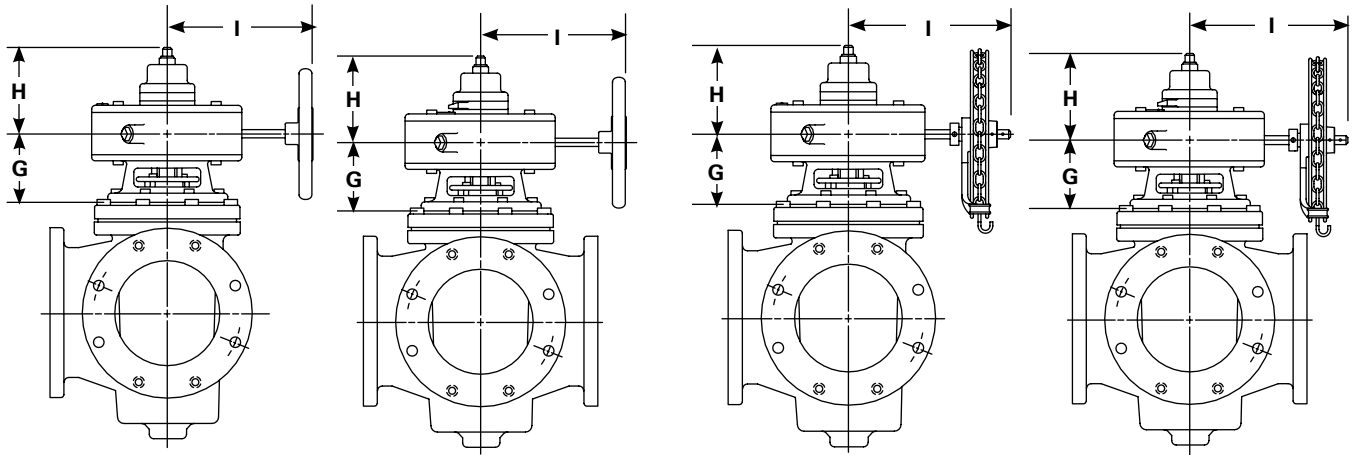

Handwheel or Chainwheel

Actuator Code	G	H
GS-6	5.69 145	6.25 159
GS-12	6.56 167	8.38 213

Inch
Millimeter

Valve Size	I			
	GS-6-HD	GS-6-CW	GS-12-HD	GS-12-CW
3 & 4" 80 & 100mm	6.88 175	9.62 244	-	-
5 & 6" 125 & 150mm	8.75 222	9.62 244	-	-
8" 200mm	11.12 282	11.12 282	-	-
10 & 16" 250 & 400mm	-	-	17.88 454	17.38 442

Inch
Millimeter

Dimensions

Lift, Turn, Reseat Handwheel/ Chainwheel

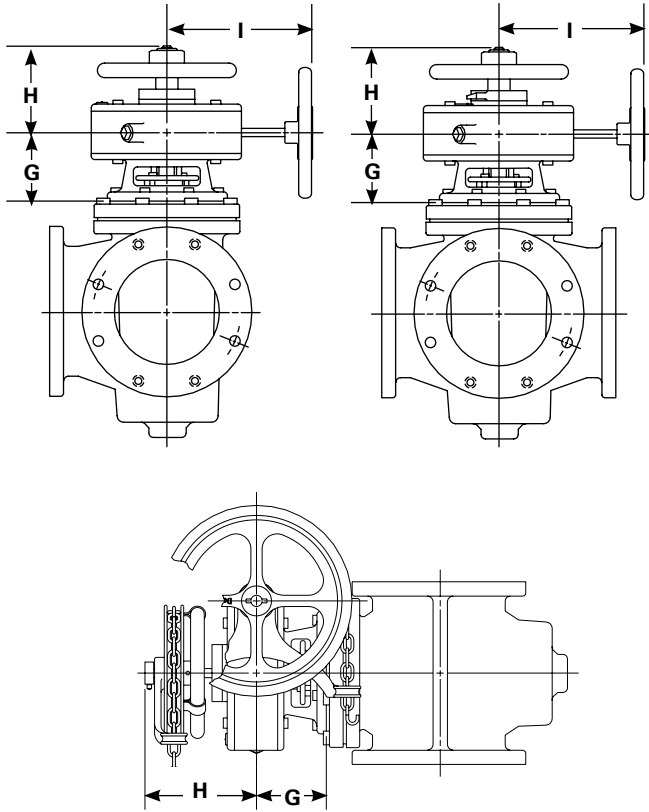

Actuator Code	G	H	
		Handwheel	Chainwheel
GSL-6	5.69	5.75	7.94
	145	146	202
GSL-12	6.56	6.50	8.62
	167	165	219

Inch
Millimeter

Cylinder Actuators

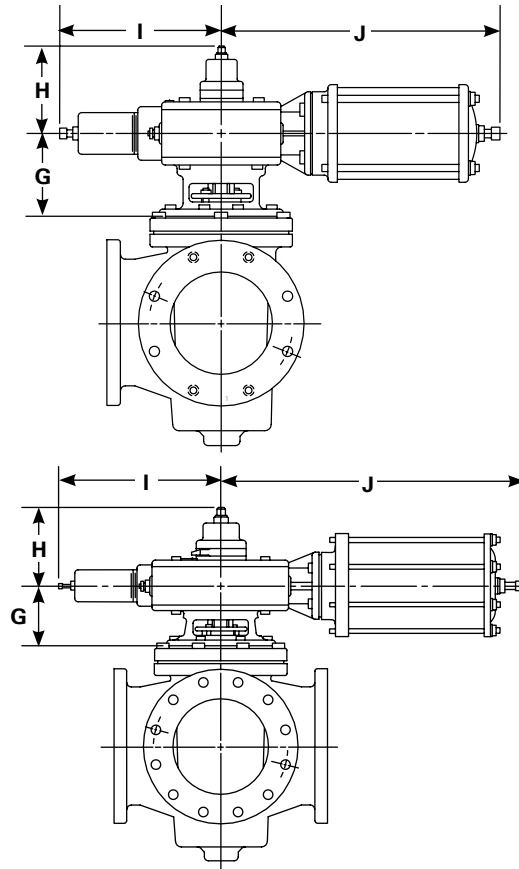

Actuator Code	G	H
GS-6-PC_	5.69 145	6.25 159
GS-12-PC_	6.56 167	8.38 213

Inch
Millimeter

Valve Size	I			
	GS-6-HD_	GS-6-CW_	GS-12-HD_	GS-12-CW_
3 & 4" 80 & 100mm	6.88 175	9.62 244	-	-
5 & 6" 125 & 150mm	8.75 222	9.62 244	-	-
8" 200	11.12 282	11.12 282	-	-
10 & 16" 250 & 400mm	-	-	17.88 454	17.38 442

Inch
Millimeter

Actuator Code	I	J
GS-6-PC6	11.00	19.12
	279	486
GS-6-PC8	11.00	19.38
	279	492
GS-12-PC8	17.50	30.88
	445	784
GS-12-PC10	17.50	31.00
	445	787

Inch
Millimeter

Sales and Service

For information about our worldwide locations, approvals, certifications and local representative:

Web Site: www.sartellvalves.com E-Mail: info@sartellvalves.com

SARTELL Valves, Inc.

DeZURIK Water Controls

SARTELL Valves & Controls

250 Riverside Ave. N. Sartell, Minnesota 56377 • Phone: 320-259-2000 • Fax: 320-259-2227

Sartell Valves, Inc. reserves the right to incorporate our latest design and material changes without notice or obligation. Design features, materials of construction and dimensional data, as described in this bulletin, are provided for your information only and should not be relied upon unless confirmed in writing by Sartell Valves, Inc. Certified drawings are available upon request.

Printed in the U.S.A.