

Book 2: Chapter 6 - Above Grade Supporting

Above grade applications frequently require non-continuous support for DriscoPlex™ OD controlled polyethylene pipe. Such applications usually involve piping in a rack or trestle, on sleepers, or suspended from an overhead structure. In such cases, structures must provide

Figure 6-1 Pipeline Supports

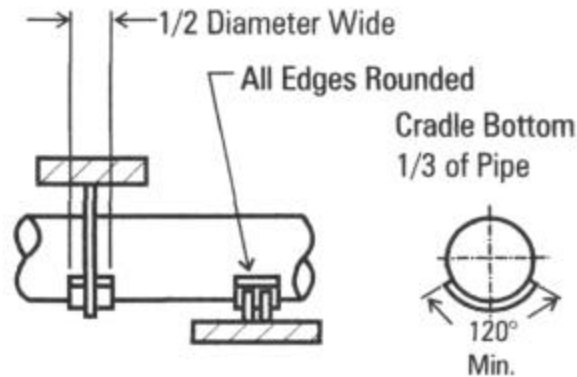

proper pipeline support, accommodate thermal expansion and contraction movement, and provide support spacing that limits vertical deflection between supports.

Supports for DriscoPlex™ OD controlled pipe must cradle at least the bottom 120° of the pipe,

Figure 6-2 Pipeline Hanger

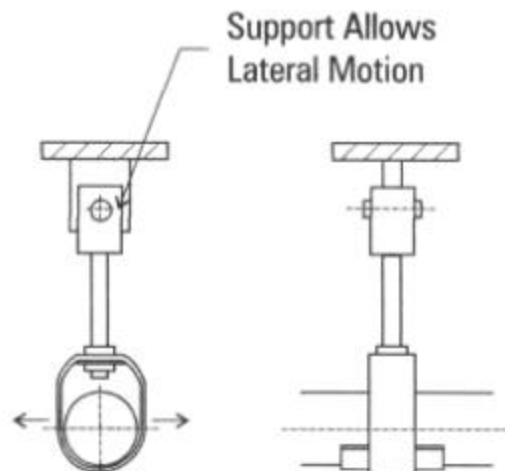

and be at least $1/2$ pipe diameter wide. Edges should be rounded or rolled to prevent cutting into the pipe. Commercial pipe supports such as u-bolts, narrow strap-type hangers, and roller type supports are unsuitable unless modified for width and cradling. The weight of the pipe and its contents must be distributed over a broad surface. Narrow support surfaces can produce

Figure 6-3 Deflection Between Supports

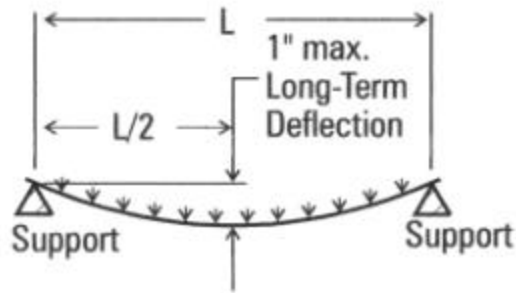

high concentrated stress, and possibly lead to pipeline failure.

Support Spacing

Support spacing depends upon the allowable deflection between supports, which in turn depends upon the pipeline, the fluid within it, and the service temperature. Performance Pipe recommends that the allowable long-term deflection between supports should not exceed 1". Recommended support spacing may be determined from Formula 6-1.

$$L_S = \sqrt[4]{\frac{384 E I y_S}{5 (W_P + W_F)}} \quad (6-1)$$

where:

- L_S = distance between supports, in
- E = long-term modulus for the service temperature, lb/in² (Table 5-1)
- I = moment of inertia, in⁴ (Formula 5-5)
- y_S = deflection between supports, in
- W_P = weight of pipe, lb/in
- W_F = weight of fluid in pipe, lb/in

Each support along a piping run is loaded from both sides. When run supports are equally spaced, the load on supports along the run is:

$$W_{RUN} = L (W_P + W_F) \quad (6-2)$$

where:

- W_{RUN} = load on supports along the run, lb

The supports at the beginning and the end of the run are loaded from only one side, thus the load on end supports is:

$$W_{END} = \frac{L (W_P + W_F)}{2} \quad (6-3)$$

where:

- W_{END} = load on end supports, lb

Figure 6-5 Pipe Rack - Center Anchored

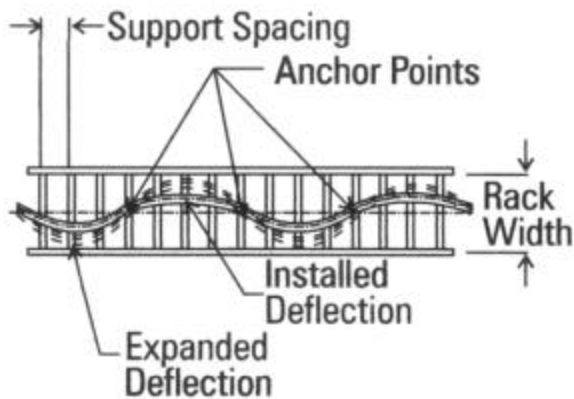
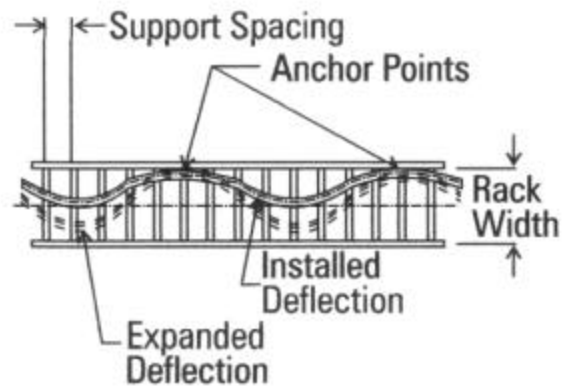

Figure 6-4 Pipe Rack - Side Anchored



Pipe Rack Support

Pipes supported in an overhead rack require design consideration for both support spacing and thermal length change. Support beams are spaced according to vertical deflection limits, and the rack width accommodates the total thermal expansion offset plus the diameter of the pipe. Pipe supports should be allowed to move along support beams, or otherwise accommodate horizontal movement as the pipe deflects laterally with changing temperature. See Chapter 5, "Thermal Effects," for more information.

Center anchored pipes must be allowed to pivot at the anchor point. Side anchored pipes may be rigidly fixed to the side of the rack.

Several parallel DriscoPlex™ OD controlled pipes may be accommodated in racks by spacing supports as required for the smallest diameter pipe, and providing a rack wide enough for all of the pipes. Thermal length change is independent of the pipe diameter, so for the same temperature variation, length change and lateral deflection will be the same for DriscoPlex™ OD controlled pipes regardless of pipe diameter.

DriscoPlex™ OD controlled pipes may be placed in racks parallel to pipes such as steel or fiberglass by using the side anchoring approach. The rack should be widened to accommodate total horizontal deflection, and additional support beams added as required. Non-polyethylene pipes should be located on the anchored side to allow the DriscoPlex™ OD controlled pipe to deflect horizontally to the opposite side of the rack.

Consult Performance Pipe for all above grade applications for DriscoPlex™ 2000 SPIROLITE® pipe.

Table 6-1 Support Spacing at 73°F (23°C)?

IPS size	OD, in	Support Spacing, ft								
		DR 7.3	DR 9	DR 11	DR 13.5	DR 17	DR 21	DR 26	DR 32.5	DR 41
2	2.375	5.3	5.1	4.9						
3	3.500	6.4	6.2	6.0	5.8	5.5	5.3			
4	4.500	7.3	7.0	6.8	6.5	6.3	6.0	5.7	5.4	
5	5.563	8.1	7.8	7.6	7.3	7.0	6.7	6.4	6.0	
6	6.625	8.8	8.5	8.3	7.9	7.6	7.3	6.9	6.6	
8	8.625	10.1	9.7	9.4	9.1	8.7	8.3	7.9	7.5	
10	10.750	11.2	10.9	10.5	10.1	9.7	9.2	8.8	8.4	
12	12.750	12.2	11.9	11.5	11.0	10.5	10.1	9.6	9.1	
14	14.000	12.8	12.4	12.0	11.5	11.0	10.6	10.1	9.6	
16	16.000	13.7	13.3	12.8	12.3	11.8	11.3	10.8	10.2	
18	18.000	14.5	14.1	13.6	13.1	12.5	12.0	11.4	10.9	
20	20.000	15.3	14.8	14.3	13.8	13.2	12.6	12.0	11.5	
22	22.000	16.1	15.6	15.0	14.5	13.8	13.2	12.8	12.0	
24	24.000	16.8	16.3	15.7	15.1	14.4	13.8	13.2	12.5	
26	26.000	17.5	16.9	16.3	15.7	15.0	14.4	13.7	13.1	
28	28.000		17.6	17.0	16.3	15.6	14.9	14.2	13.5	
30	30.000		18.2	17.6	16.9	16.1	15.4	14.7	14.0	13.3
32	32.000		18.8	18.1	17.5	16.7	15.9	15.2	14.5	13.7
34	34.000			18.7	18.0	17.2	16.4	15.7	14.9	14.2
36	36.000			19.2	18.5	17.7	16.9	16.2	15.4	14.6
42	42.000				20.0	19.1	18.3	17.4	16.6	15.7
48	48.000				21.4	20.4	19.5	18.6	17.7	16.8
54	54.000					21.7	20.7	19.8	18.8	17.8

? Support spacing for pipe at 73°F (23°C) filled with 73°F (23°C) water. Spacing will vary for different temperature and for different fluids in the pipe.