

## Book 2: Chapter 5 - Thermal Effects

Like most materials, polyethylene is affected by temperature change. However, polyethylene's response to temperature change is significant and unique when compared to other "traditional" piping materials. Polyethylene pipe design for thermal change may be significantly different compared to other piping materials.

The effect of temperature on chemical resistance is discussed in the *Performance Pipe Engineering Manual, Book 1: Engineering Properties*. In this book, Chapter 3, *Pressure Rating Design* discusses pressure rating change for different service temperatures.

Polyethylene pipe can be installed and operated in sub-freezing conditions. Ice in the pipe will restrict or stop flow, but not cause pipe breakage. Care must be taken during installation to avoid impact and suddenly applied high stress, and temperature change will result in a dimension change or a stress increase in the pipe wall depending on the installation.

In response to changing temperature, unrestrained polyethylene pipe will undergo a length change. Anchored or end restrained pipe will develop longitudinal stresses instead of undergoing a change in length. This stress will be tensile during temperature decrease, or compressive during temperature increase. If the compressive stress level exceeds the column buckling resistance of the restrained length, then lateral buckling (or snaking) will occur. While thermal stresses are well tolerated by polyethylene pipe, anchored or restrained pipe may apply stress to restraining structures. The resulting stress or thrust loads can be significant and the restraining structures must be designed to resist the anticipated loads.

### **Unrestrained Thermal Effects**

The theoretical change in length for an unrestrained pipe placed on a frictionless surface can be determined from Formula 5-1.

$$\Delta L = L \alpha \Delta T \quad (5-1)$$

where:

$\Delta L$	=	length change, in
$L$	=	pipe length, in
$\alpha$	=	thermal expansion coefficient, in/in/°F
$\Delta T$	=	temperature change, °F

The coefficient of thermal expansion for DriscoPlex® PE 3408 polyethylene pipe material is about  $9.0 \times 10^{-5}$  in/in/°F. This coefficient results in an approximate expansion for pipe of 1/10/100, that is, 1 in for each 10° F change for each 100 ft of pipe. This is a significant length change compared to other piping materials and should be taken into account in piping system design. A temperature rise results in a length increase while a temperature drop results in a length decrease.

### **End Restrained Thermal Effects**

A length of pipe that is restrained or anchored on both ends and placed on a frictionless surface will exhibit a substantially different reaction to temperature change than an unrestrained pipe. If the pipe is restrained in a straight line between two points and the temperature decreases, the pipe will attempt to decrease in length. Because of the end restraints, a length change is not possible, so a tensile stress is created in the longitudinal direction along the pipe. This stress

can be determined using the Formula 5-2.

$$\sigma = E \alpha \Delta T \quad (5-2)$$

where terms are as defined above, and

$\sigma$  = longitudinal stress in pipe, psi  
 $E$  = elastic modulus, psi

**The selection of the modulus can have a large impact on the calculated stress.** As with all thermoplastic materials, polyethylene's modulus and therefore its stiffness, is a function of temperature and the duration of the applied load. To select the appropriate elastic modulus, these two variables must be known. When determining the appropriate time interval, it is important to consider that heat transfer occurs at relatively slow rates through the wall of polyethylene pipe, therefore temperature changes do not occur rapidly. Because the temperature change does not happen rapidly, the average temperature is often chosen for the modulus selection.

As longitudinal stress builds in the pipe wall, a thrust load is created on the end structures. This load can be significant and is determined by Formula 5-3.

$$F = \sigma A \quad (5-3)$$

where terms are as defined above, and

$F$  = end thrust, lb  
 $A$  = cross section area of pipe, in<sup>2</sup>

Formulas 5-2 and 5-3 can also be used to determine the compressive stress and thrust (respectively) that is created when a temperature increase occurs. However, if the compressive thrust exceeds the critical longitudinal buckling force for the pipe segment, the pipe will deflect laterally. The critical force for a slender column can be determined using Euler's equation, assuming ends are free to rotate (which is conservative for restrained ends).

Euler's Equation

$$F' = \frac{\pi^2 E I}{(L')^2} \quad (5-4)$$

where terms are as defined above, and

$F'$  = critical thrust force, lb  
 $I$  = cross section moment of inertia, in<sup>4</sup>

$$I = \frac{\pi (OD^4 - ID^4)}{64} \quad (5-5)$$

$L'$  = distance between end restraints, in

The modulus is selected using the same criteria used for determining the stress in the pipe wall due to the thermal change.

While the amount of length change experienced by polyethylene pipe during thermal changes is greater than many other materials, the amount of force required to restrain the movement is less because of its lower modulus of elasticity.

**Table 5-1 Typical Elastic Modulus for DriscoPlex® PE 3408**

Load Duration	Elastic Modulus†, 1000 psi (MPa), at Temperature, °F (°C)							
	-20 (-29)	0 (-18)	40 (4)	60 (16)	73 (23)	100 (38)	120 (49)	140 (60)
Short-Term	300.0 (2069)	260.0 (1793)	170.0 (1172)	130.0 (896)	110.0 (758)	100.0 (690)	65.0 (448)	50.0 (345)
10 h	140.8 (971)	122.0 (841)	79.8 (550)	61.0 (421)	57.5 (396)	46.9 (323)	30.5 (210)	23.5 (162)
100 h	125.4 (865)	108.7 (749)	71.0 (490)	54.3 (374)	51.2 (353)	41.8 (288)	27.2 (188)	20.9 (144)
1000 h	107.0 (738)	92.8 (640)	60.7 (419)	46.4 (320)	43.7 (301)	35.7 (246)	23.2 (160)	17.8 (123)
1 y	93.0 (641)	80.6 (556)	52.7 (363)	40.3 (278)	38.0 (262)	31.0 (214)	20.2 (139)	15.5 (107)
10 y	77.4 (534)	67.1 (463)	43.9 (303)	33.5 (231)	31.6 (218)	25.8 (178)	16.8 (116)	12.9 (89)
50 y	69.1 (476)	59.9 (413)	39.1 (270)	29.9 (206)	28.2 (194)	23.0 (159)	15.0 (103)	11.5 (79)

† Typical values based on ASTM D 638 testing of molded plaque material specimens.

### Controlling Expansion and Contraction

Black polyethylene pipe on the surface or above grade and exposed to the sun can absorb solar energy. The resulting pipe temperatures can be greater than the air temperature. To help reduce temperature changes resulting solar heating of a piping system, the pipe may be shaded or placed in a location that receives less direct sunlight.

The effects of thermal expansion and contraction on a piping system can be controlled in several ways, including

- ❑ Lateral deflection expansion loops (snaking the pipe)
- ❑ Anchor and guide the pipe
- ❑ Conventional Expansion loops
- ❑ Expansion joints (non-pressures systems only)
- ❑ Burying pipes

### Lateral Deflection Expansion Loops

The simplest installation involves stringing pipe between end point anchor structures. If the pipe is simply laid in a straight line between the end anchors the pipeline anchoring structures must be capable of handling potentially high thermal contraction thrust loads during temperature decrease, and during temperature increase, the maximum compressive thrust is the force required to cause lateral deflection at which time the compressive stress and end thrust will then

**Figure 5-1 Lateral Deflection**

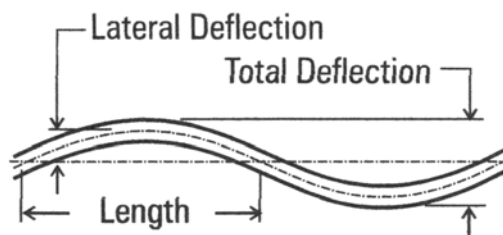

decrease. To minimize these loads, pipe may be pre-snaked during installation.

Snaked piping installations are also referred to as lateral deflection expansion loops. These loops can be used for DriscoPlex<sup>®</sup> piping systems that are laid on the surface, supported or suspended above grade on hangers or in racks, or installed underwater.

An effective flexible pipe expansion loop system employs the pipe's natural tendency to deflect laterally, and its high strain tolerance. Lateral deflection expansion loops are recurrent "S-curves" (snaking) along the piping runs that provide an initial lateral deflection, and allow pipe temperature changes to result in greater or lesser lateral deflection.

Surface and rack supported pipe systems designed with lateral deflection expansion loops must provide sufficient width allowance for lateral pipe deflection. The amount of lateral deflection is related to the anchors or guides spacing.

An end restrained pipe that experiences a temperature rise will deflect laterally if the thrust force exceeds the force given in Formula 5-4.

Lateral deflection may be approximated by

$$y = L \sqrt{\frac{\alpha \Delta T}{2}} \quad (5-6)$$

where

- y = lateral deflection, in
- L = distance between endpoints, in
- $\alpha$  = thermal expansion coefficient, in/in/°F
- $\Delta T$  = temperature change, °F

A long, semi-restrained pipe run can snake to either side of the run centerline. Total deflection is

$$Y_T = 2(\Delta y) + D \quad (5-7)$$

where terms are as defined above and

- $Y_T$  = total deflection, in
- D = pipe diameter, in

To minimize thrust loads on restraints or to control which side of the centerline the pipe snakes, an initial deflection can be provided so the pipe does not contract to a straight line at minimum expected temperature. Likewise, during thermal expansion, pipe that is pre-snaked requires less force than predicted using Formula 5-4 to continue snaking. At the time of installation, the anticipated temperature change from installation temperature to minimum temperature should be determined. Using this temperature change and the distance between points, determine lateral deflection, and install the pipe with this lateral deflection plus the minimum lateral deflection specified by the designer.

The minimum allowable distance between restraining points is dependent upon pipe lateral deflection or bending strain and may be determined from

$$L = \frac{D \sqrt{96 \alpha (\Delta T)}}{\epsilon_{allow}} \quad (5-8)$$

where terms are as defined above and

- $\epsilon_{allow}$  = allowable bending strain, in/in

Published values for allowable field cold bend radii of pressure pipe can be used to determine the allowable bending strain.

**Table 5-2 Allowable Bending Strain**

Pipe Dimension Ratio, DR	Allowable Bending strain, $\epsilon_{allow}$ , in/in
$\leq 13.5$	0.025
$> 13.5 - 21$	0.020
$> 21$	0.017
Pipe with Fittings	0.005

Where pipe is connected to rigid devices, fabricated directional fittings or where flanges or other rigid connections are employed, the pipe must be protected from shear, flexing and bending. Flanges laid on the surface can become anchored in the soil, and should be supported on sleepers. Figure 5-2 illustrates a method for protecting connections to directional fittings and flanged connections to other appurtenances. Wrap elastomer or rubber sheet material around the pipe under the clamps.

End points and mid points of pipe run lengths will require anchoring or guiding. Endpoint anchors must transfer loads and deflections to the pipe, away from rigid joints, or fittings. Midpoint anchors or guides must remain in location, but allow the pipe to move or pivot with the lateral deflection of the expansion loop. Figure 5-3 shows possible anchoring methods.

**Figure 5-2 Anchoring Flange Connections**

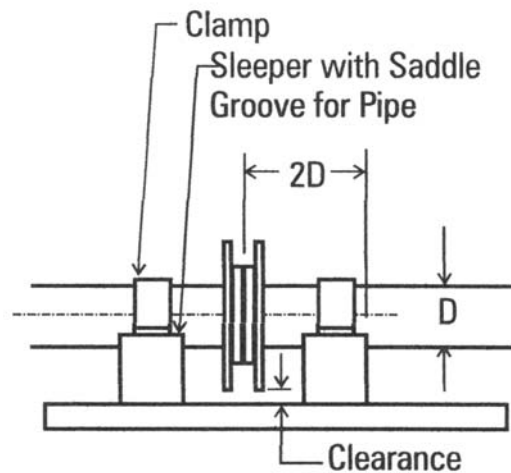

**Figure 5-3 Midpoint and End Anchoring**

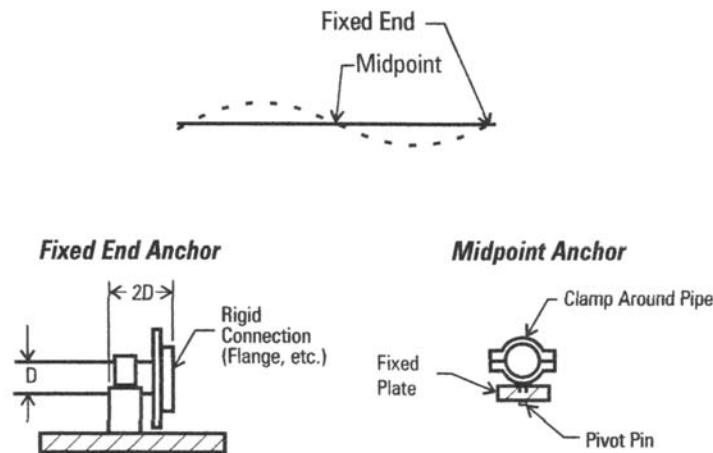

sheeting around the pipe under clamps to protect the pipe from chafing.

Above grade piping may also be hung from support rods. Hangers must allow for lateral deflection with sufficient support rod length, and with a clevis or ball type joint at the suspension point. See Chapter 6 for additional information on above grade piping.

---

### **Example 5-1**

24" SDR 11 pipe is conveying a liquid and lying on the ground with an installation temperature of 60° F and operating conditions between 20° F and 120° F. The line is to be installed in a straight line between guides. Installing a line straight between guides results in maximum end thrust loads (tension and compression) on the anchors. Pre-snaking the line will reduce the anchor thrust loads. (a) What is the minimum distance between guides? (b) How much lateral deflection occurs? (c) How much thrust load is generated at the end structures/anchors?

**Solution:** (a) During thermal expansion, the minimum distance between guides can be determined using Formula 5-8.

$$L = \frac{24 \sqrt{96 (9 \times 10^{-5})(60)}}{0.025}$$

$$L = 691.2 \text{ in}$$

(b) The resultant lateral deflection between points is found using Formula 5-6.

$$y = 691.2 \sqrt{\frac{(9 \times 10^{-5})(60)}{2}}$$

$$y = 35.9 \text{ in}$$

The total deflection can now be determined using Formula 5-7.

$$Y_T = 2(35.9) + (24)$$

$$Y_T = 95.8 \text{ in}$$

Formula 5-8 provides the minimum distance between guides based on the strain from lateral deflection. Using the Formula 5-6 minimum distance (spacing) between pipeline guide points provides the smallest theoretical lateral deflection. Increasing the spacing will increase the lateral deflection (offset) and require a wider pipeline right-of-way, but will decrease the compressive thrust load on end or guide points from thermal expansion.

(c) An estimate of the maximum longitudinal compressive thrust force based on the minimum guide spacing of 691.2 inches, can be determined from Formula 5-4.

$$F = \frac{(3.14)^2 (50800)(9369)}{(619.2)^2}$$

$$F = 9833 \text{ lb}$$

Thermal contraction of the pipe results in a tensile stress in the pipe wall that can be determined

from Formula 5-2, and then compared to the allowable tensile stress determined from Formula 5-9.

$$\sigma = (79800)(9 \times 10^{-5})(40)$$

$$\sigma = 287 \text{ psi}$$

$$\sigma_{allow} = (1600)(0.50)(1.2)$$

$$\sigma_{allow} = 960 \text{ psi}$$

The tensile load on the end anchors can be determined from Formula 5-3.

$$F = (287)(157.57)$$

$$F = 4527 \text{ lb}$$

This example assumes a straight installation. If the line is pre-snaked, additional right-of-way may be required, however the loads on the end anchors would be decreased because of the pre-snaked condition.

### Anchored and Guided Pipe

If the space required for lateral deflection expansion loops is not available, the pipe may be anchored at the end points and guided frequently enough so that snaking (column buckling) does not occur. **This method results in longitudinal thrust and may require significant end anchoring structures.**

For this discussion, anchoring restrains the pipe such that movement is not allowed in any direction, that is, longitudinal, lateral or vertical. Guides between the end anchors should allow the pipe to slide freely through the guide. Fabricated fittings and rigid connections such as flanges and transition fittings must be protected from bending, therefore if anchors are used to protect a fitting from bending stresses, all of the fitting outlets must be anchored.

**Anchored and guided piping systems require analysis of both the temperature increase and decrease.**

As pipeline temperature decreases from weather or processing conditions, tensile stress develops along the length of the pipe. The stress can be calculated using Formula 5-2, and should not exceed the allowable tensile stress determined from Formula 5-9.

**Figure 5-4 Typical Guides**

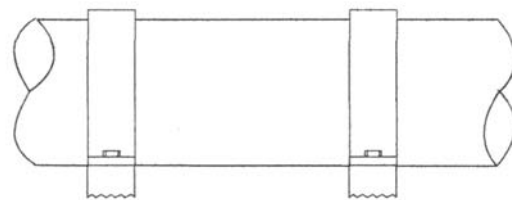

$$\sigma_{allow} = HDB f_e f_t \tag{5-9}$$

where

- $\sigma_{\text{allow}}$  = allowable tensile stress, lb/in<sup>2</sup>
- HDB = Hydrostatic Design Basis, lb/in<sup>2</sup> (Table 2-1)
- $f_e$  = environmental design factor (Table 3-1)
- $f_t$  = service temperature design factor (Table 3-2)

Tensile stress causes an end thrust at the anchors that can be calculated using Formula 5-3. **Anchors or end structures should be designed to withstand this thrust without allowing movement of the pipe in any direction.**

During temperature increase, the pipeline attempts to increase its length. The anchors prevent length increase, creating longitudinal compressive stress in the pipe and a thrust load against the anchors. Compressive stress can be determined using Formula 5-2 and should not exceed the allowable stress per Formula 5-9. (For polyethylene materials, long-term tensile and compressive strengths are about the same. For convenience, the HDB value is used as a conservative value for allowable long-term compressive strength.) Guides must be placed at intervals not exceeding the column buckling length of the pipe per Formula 5-4. Combining Formulas 5-3 and 5-4 yields Formula 5-10 for guide spacing.

$$L_{\text{guide}} = \sqrt{\frac{\pi^2 I}{N \alpha \Delta T A}} \quad (5-10)$$

where terms are as previously defined and

- $L_{\text{guide}}$  = distance between guides, in
- $I$  = cross section moment of inertia, in<sup>4</sup> (Formula 5-5)
- $N$  = safety factor
- $A$  = pipe cross section area, in<sup>2</sup>

$$A = \frac{\pi}{4} (OD^2 - d^2) \quad (5-11)$$

where

- OD = pipe outside diameter, in
- d = pipe inside diameter, in (Formula 4-1)

Combining Formula 5-11 with Formula 3-3 yields:

$$A = \pi OD^2 \left( \frac{1}{DR} - \frac{1}{DR^2} \right) \quad (5-12)$$

An appropriate safety factor should be used when determining guide spacing. While the guides allow for longitudinal movement of the pipe, they must resist lateral and vertical movement. The following rule of thumb for steel columns may be considered. When designing steel columns, a reaction load of 10% of the force that induces a longitudinal buckle of the column is used to resist lateral movement of the column and therefore resist buckling.

---

### Example 5-2

Determine the guide spacing and anchor loads for 8" SDR 11 installed at 70° F with a maximum operating temperature of 130° F and a minimum operating temperature of 10° F. The minimum time for a processing condition temperature is 10 hours.

**Solution:** For thermal expansion, use Formula 5-2 to determine the longitudinal compressive stress developed using a 10-hour modulus at 100° F (Table 5-1).

$$\sigma = (46900)(9 \times 10^{-5})(60)$$

$$\sigma = 253 \text{ psi}$$

$$\sigma_{allow} = (1600)(0.50)(0.63)$$

$$\sigma_{allow} = 504 \text{ psi}$$

The force generated on the end structures can be determined using Formula 5-3.

$$F = (253)(20.35)$$

$$F = 5149 \text{ lb}$$

Use Formula 5-10 to determine spacing between guides.

$$L_{guide} = \sqrt{\frac{(314)^2(156.28)}{(2)(9 \times 10^{-5})(60)(20.35)}}$$

$$L_{guide} = 83.7 \text{ in}$$

For thermal contraction, use Formula 5-2 to determine the longitudinal tensile stress using a 10-hour modulus at 40° F.

$$\alpha = (79800)(9 \times 10^{-5})(60)$$

$$\alpha = 431 \text{ psi}$$

$$\sigma_{allow} = (1600)(0.50)(1.2)$$

$$\sigma_{allow} = 960 \text{ psi}$$

The force generated on the end structures can be determined using Formula 5-3.

$$F = (431)(20.35)$$

$$F = 8771 \text{ lb}$$

## Conventional Expansion Loops

Conventional expansion loops reduce end point anchor structural requirements, but may require more space. Typical expansion loop designs use fittings to create an offset and return to the original piping run. However, long runs of flexible polyethylene pipe would rather deflect laterally than push, so expansion loop designs should utilize guides that permit longitudinal slippage, but not lateral deflection to direct length change to the expansion loop. Conventional fitting-style expansion loops are generally limited to piping systems where molded fittings are available. **Large diameter fabricated fittings must be protected against bending and flexure stresses with cross bracing or other suitable means.** (See Book 3, Figure 3-16.)

Figure 5-5 Conventional Expansion Loop

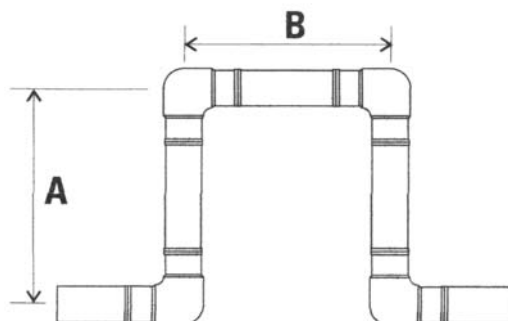

**The following protocol is for suspended expansion loops only.** When designing conventional expansion loops, first determine the maximum length change from temperature change for the pipe run. The maximum run length change run may occur during expansion or contraction and can be determined using Formula 5-1.

Next, determine the required leg length “A” for the loop. The “A-leg” length is determined from Formula 5-13 for a cantilever beam with a concentrated load.

$$L_A = \sqrt{\frac{3}{2} \frac{D \Delta L}{\epsilon_{allow}}} \quad (5-13)$$

where

- $L_A$  = expansion loop leg “A” length, in
- OD = pipe outside diameter, in
- $\Delta L$  = length change in pipe run, in
- $\epsilon_{allow}$  = allowable bending strain for pipe with fittings, in/in (Table 5-2)

The length of the “B-leg” is typically one half the “A-leg” length.

$$L_B = \frac{L_A}{2} \quad (5-14)$$

Once the dimensions of the loop have been determined, the next step is to determine the frequency at which the runs must be guided so that the activation force required for the loop is not greater than the column buckling resistance strength of the run. Combining Euler’s equation (Formula 5-4) with Formula 5-13 yields

$$L_{guide} = \sqrt{\frac{\pi^2 (L_A)^3}{3 \Delta L}} \quad (5-15)$$

where

- $L_{\text{guide}}$  = pipe run guide spacing, in
- $OD$  = pipe outside diameter, in
- $\Delta L$  = length change in pipe run, in
- $\epsilon_{\text{allow}}$  = allowable bending strain for pipe with fittings, in/in (Table 5-2)

Guides should allow for longitudinal pipe slippage. For above grade piping, the guide spacing is the smaller of the result from Formula 5-14 or from Formula 6-1. Where the pipe is to be anchored or terminated, the end or anchor structure must be designed to withstand the force necessary to activate the expansion loop. This force can be theoretically determined by from Formula 5-16.

$$F_L = \frac{\Delta L 3EI}{L_A^3} \quad (5-16)$$

where

$$F_L = \text{force required to active expansion loop, lb}$$

Two guides may be required on each side of the expansion loop to restrict bending of the pipeline run. The guide closest to the loop should be placed far enough back from the 90° elbow so that the fitting does not contact the guide. The second guide should be placed about ten (10) pipe diameters back from the first guide.

Expansion loops that are on the surface must take the frictional resistance between the pipe and surface into account in determining guide spacing. See Chapter 6, *Above Grade Supporting*, for more information.

### **Example 5-3**

Determine the A and B leg lengths, and the activation force for a suspended 4" SDR 17 pipeline installed with conventional expansion loops every 200 feet (2400 in). The minimum operating temperature is 40° F with an installation temperature of 80° F and a maximum temperature of 100° F.

**Solution:** First determine the maximum length change, using Formula 5-1. In this case, the maximum length change results from the greater temperature difference during contraction (80°F - 40°F = 40°F) rather than during expansion (100°F - 80°F = 20°F).

$$\Delta L = (2400) (9 \times 10^{-5}) (60)$$

$$\Delta L = 12.96 \text{ in}$$

Next, determine leg length "A" of the expansion loop using equation (5-13).

$$L_A = \sqrt{\frac{\frac{3}{2} (4.5) (12.96)}{0.005}}$$

$$L_A = 132.3 \text{ in}$$

From Formula 5-14, leg length "B" is half of length "A".

$$L_B = \frac{132.3}{2} = 66.2 \text{ in}$$

Now determine the guide spacing from Formula 5-15.

$$L_{\text{guide}} = \sqrt{\frac{(3.14)^2 (132.3)^3}{(3)(12.96)}}$$

$$L_{\text{guide}} = 766 \text{ in}$$

While the guides allow for longitudinal movement, end structures/anchors are designed to withstand the activation force determined from Formula 5-16. A short-term modulus provides conservative results.

$$F_L = \frac{(12.96)(3)(110000)(8.31)}{(132.3)^3}$$

$$F_L = 15.3 \text{ lb}$$

## Expansion Joints

If used, expansion joints must be specifically intended for use with HDPE pipe. These joints activate at very low longitudinal forces and permit large movements. Expansion joints intended for use with other piping materials are not recommended for several reasons. (1) Expansion allowance is frequently insufficient for polyethylene. (2) The force required to activate the joint may exceed the column buckling strength or tensile strength of the polyethylene pipe. (3) Expansion joints for pressure service may include internal components that when exposed to internal pressure, result in a longitudinal thrust which may exceed the column buckling resistance of polyethylene pipe. Contact the expansion joint manufacturer prior to use.

## Buried Piping Systems

A buried pipe is generally well restrained by soil friction along its length, and with moderate or low temperature change, soil friction alone is usually sufficient to prevent dimensional change and expansion movement. Therefore, a buried polyethylene pipe will usually experience a change in internal stress rather than dimensional change and movement. A very significant temperature decrease may exceed soil friction restraint, and apply contraction thrust loads to pipeline appurtenances. Thrust blocks for underground pipelines are usually not required unless great temperature change is anticipated.

**Figure 5-6 Longitudinal Force Thrust Block**

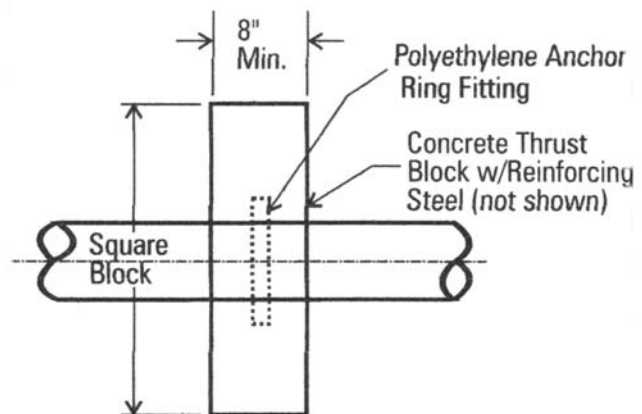

DriscoPlex® 2000 SPIROLITE® profile wall pipe is well restrained against thermal movement by the backfill soil captured between the profile ribs. Further, the bell and spigot joints are designed to accommodate possible thermal length change when the pipe is properly installed, and operated within its temperature design capabilities. DriscoPlex® 2000 SPIROLITE® pipe is most often buried, however, above grade applications may be acceptable. *Contact Performance Pipe before designing above grade applications of DriscoPlex® 2000 SPIROLITE® pipe.*

DriscoPlex® OD controlled pipe has a smooth exterior surface, and if temperature change is extreme, low thrust capacity (unrestrained) connections to manholes or other piping systems may require longitudinal force thrust block (in-line anchor) protection. See Figure 5-6.

The longitudinal stress from temperature change may be estimated using Formula 5-2. Soil load bearing capacity will require appropriate soils testing. Temperature changes below grade usually are not instantaneous, so an appropriate long-term elastic modulus from Table 5-1 should be selected. Figure 5-6 illustrates a typical thrust block design.

Where DriscoPlex® OD controlled polyethylene pipe is connected to unrestrained bell and spigot joined pressure piping systems such as ductile iron or PVC, *at a minimum*, the two bell and spigot joints closest to the connection should be restrained, or a longitudinal force thrust block (in-line anchor) should be installed near the transition connection.

## Heat Transfer

Polyethylene pipe may be heat traced, insulated, or both. Temperature limited (120°F maximum) heat tracing tape should be used, and the tape should be installed over a pressure-sensitive metallic tape installed on the pipe. The metallic tape helps distribute heat over the pipe surface.

Thermal conductivity terms:

- k = thermal conductivity, Btu/(h-ft<sup>2</sup>-°F-in)
- C = thermal conductance, BTU/(hr-ft<sup>2</sup>-°F)

$$C = \frac{k}{t} \quad (5-17)$$

- t = thickness, in
- R = thermal resistance, (hr-ft<sup>2</sup>-°F)/Btu

$$R = \frac{1}{C} \quad (5-18)$$

$$R = \frac{t}{k} \quad (5-19)$$

**Table 5-3 Thermal Properties**

Property	ASTM Reference	Nominal Value
Thermal Conductivity, k	C 177	3.5
Thermal Resistance, R (1" thickness)	—	0.3